

**REPAIR PARTS MANUAL**  
**MODEL NO. BM18H107RB (96061003200)**  
**Lawn Tractor**

---

***BESTGREEN***

# HOW TO USE THIS MANUAL

This manual is designed to provide the customer with a means to identify the parts on his/her tractor when ordering repair parts. The illustrations may or may not represent the actual assemblies; therefore, it is not recommended to use this manual as a guide to assemble or disassemble the tractor. Some hardware and parts are drawn larger in order to more readily identify them.

Each tractor has its own model number.

The model number for your tractor can be found on the fender under the seat.

When ordering parts, always give the following information:

- Product - "Tractor"
- Model Number - "BM18H107RB (96061003200)"
- Part Number
- Part Description

## TABLE OF CONTENTS

SCHEMATIC .....	3
ELECTRICAL.....	4-5
CHASSIS.....	6-7
DRIVE.....	8-9
STEERING .....	10-11
SEAT .....	12
DECALS.....	13
ENGINE.....	14
MOWER LIFT .....	15
MOWER DECK .....	16-17
BAGGER.....	18

# TRACTOR- -MODEL NO. BM18H107RB (96061003200), PRODUCT NO. 960 61 00-32 SCHEMATIC

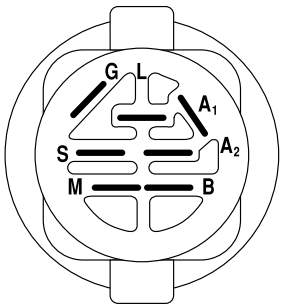
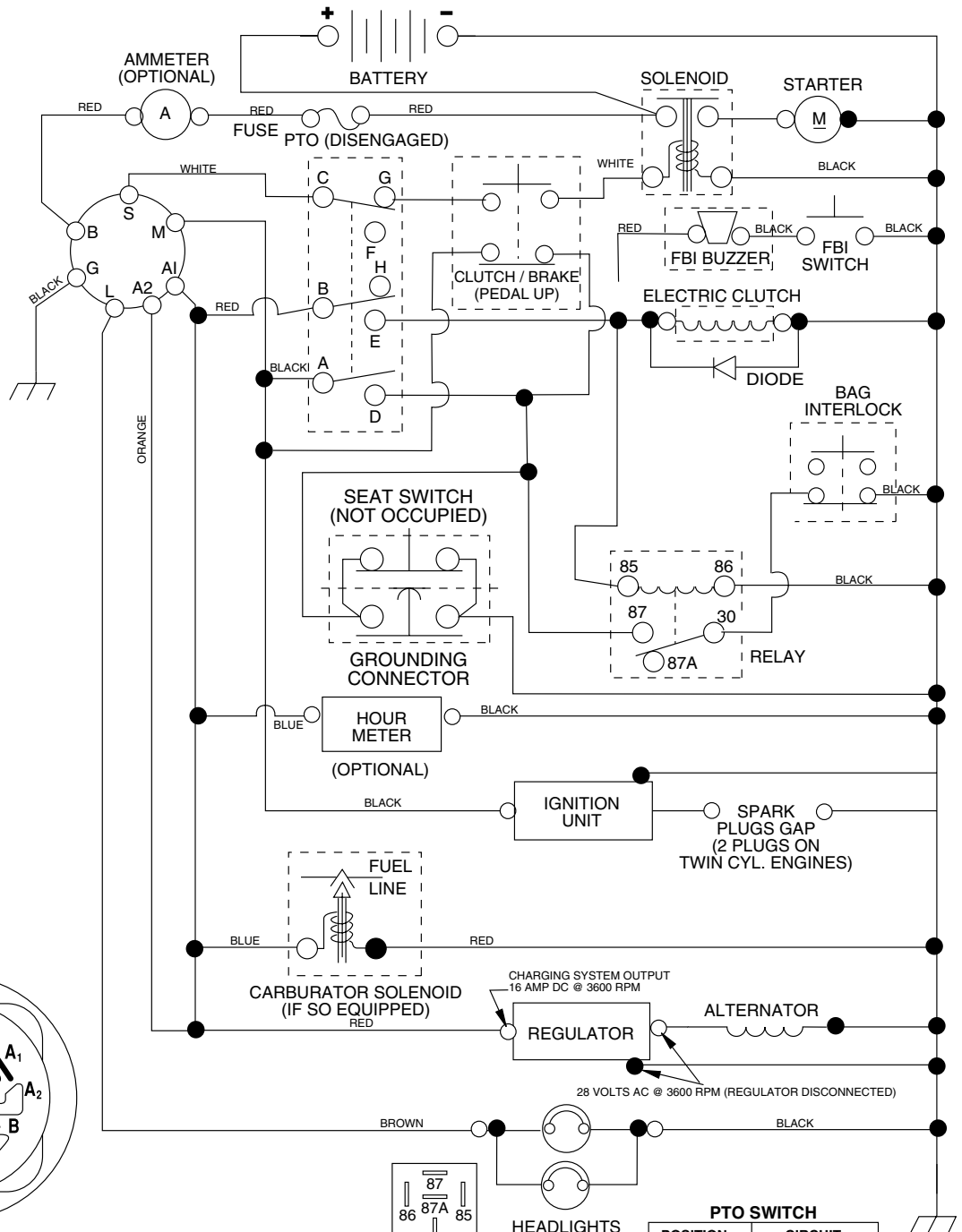

**IGNITION SWITCH**

POSITION	CIRCUIT	"MAKE"
OFF	M+G+A1	NONE
RUN/LIGHT	B+A1	A2+L
RUN	B+A1	NONE
START	B + S + A1	NONE

**WIRING INSULATED CLIPS**  
NOTE: IF WIRING INSULATED CLIPS WERE REMOVED FOR SERVICING OF UNIT, THEY SHOULD BE REPLACED TO PROPERLY SECURE YOUR WIRING.

02766

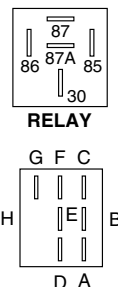

**RELAY**

PTO SWITCH	
POSITION	CIRCUIT
OFF	C + G, B + H
ON	C + F, B + E, A + D

●  
NON-REMOVABLE CONNECTIONS

○  
REMOVABLE CONNECTIONS

# REPAIR PARTS

TRACTOR- -MODEL NO. BM18H107RB (96061003200), PRODUCT NO. 960 61 00-32  
ELECTRICAL

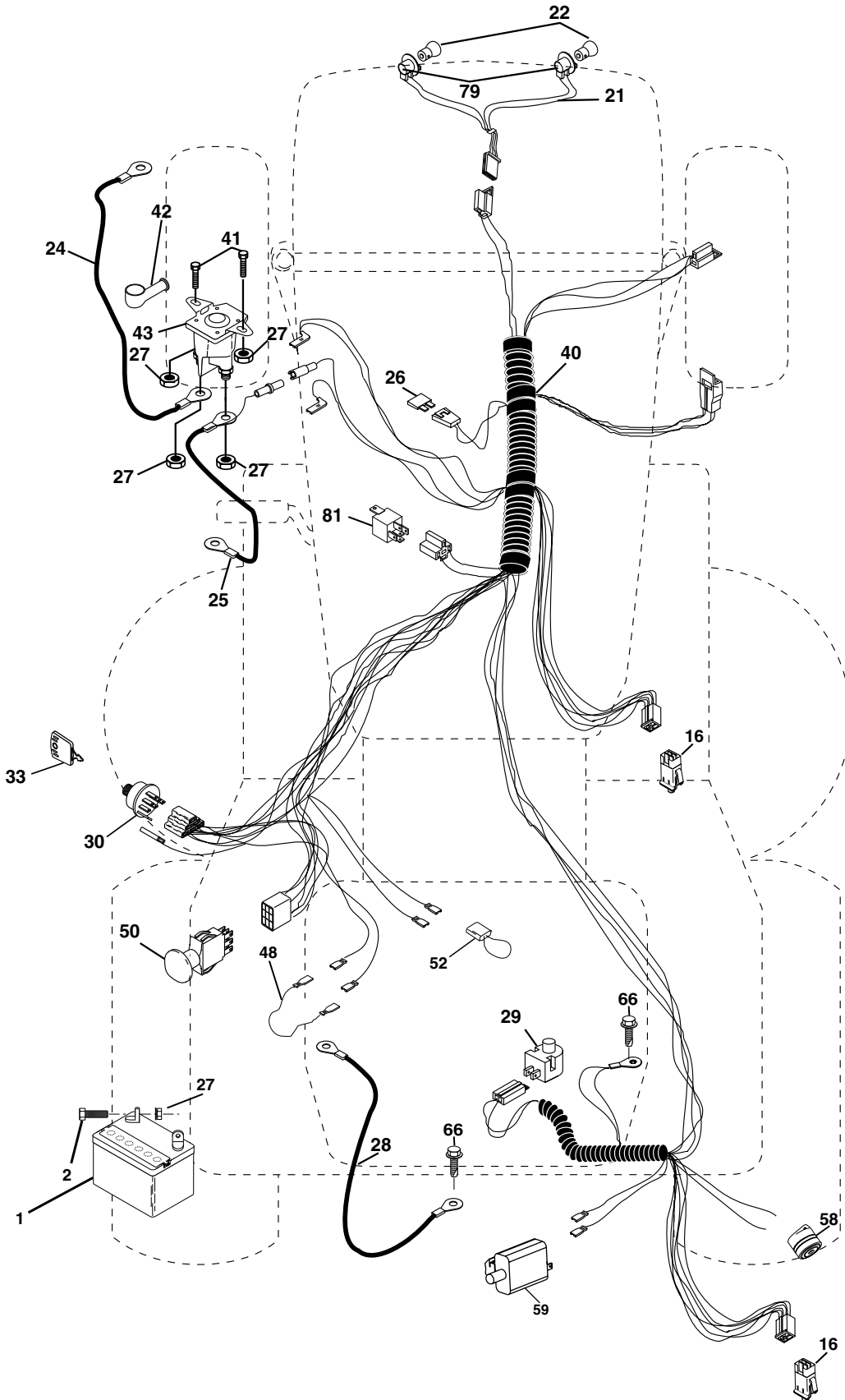

# REPAIR PARTS

TRACTOR- -MODEL NO. BM18H107RB (96061003200), PRODUCT NO. 960 61 00-32  
ELECTRICAL

KEY NO.	PART NO.	DESCRIPTION
1	532 14 49-27	Battery
2	874 76 04-12	Bolt Hex Hd 1/4-20 unc x 3/4
16	532 17 61-38	Switch Interlock
21	532 17 56-88	Harness Asm Light W/4152J
22	532 00 41-52	Bulb Light #1156
24	532 12 47-80	Cable Starter 6 Ga. 11" Red
25	532 16 59-87	Cable Battery Crd 56" Red
26	532 17 51-58	Fuse
27	873 51 04-00	Nut Keps Hex 1/4-20 unc
28	532 12 77-25	Cable Ground 6 Ga. 18" Black
29	532 12 13-05	Switch Plunger NC Gray
30	532 17 55-66	Switch Ignition
33	532 14 04-01	Key Ign
40	532 18 80-39	Harness Ign
41	871 11 04-08	Bolt Flk Fin Hex 1/4-20 unc x 1/2
42	532 13 15-63	Cover Terminal Red
43	532 17 88-61	Solenoid
48	532 19 01-08	Adapter Ammeter
50	532 17 46-51	Switch PTO
52	532 14 19-40	Protection Wire Loop
58	532 16 94-19	Buzzer Crd
59	532 18 03-79	Switch FBI CRD
66	817 49 06-08	Screw Thdrol 3/8-16 x 1/2 Ty-Tt
79	532 17 52-42	Socket Asm. Bulb Twistlock
81	532 10 97-48	Relay Asm

**NOTE:** All component dimensions given in U.S. inches.  
1 inch = 25.4 mm.

# REPAIR PARTS

TRACTOR- -MODEL NO. BM18H107RB (96061003200), PRODUCT NO. 960 61 00-32  
CHASSIS AND ENCLOSURES

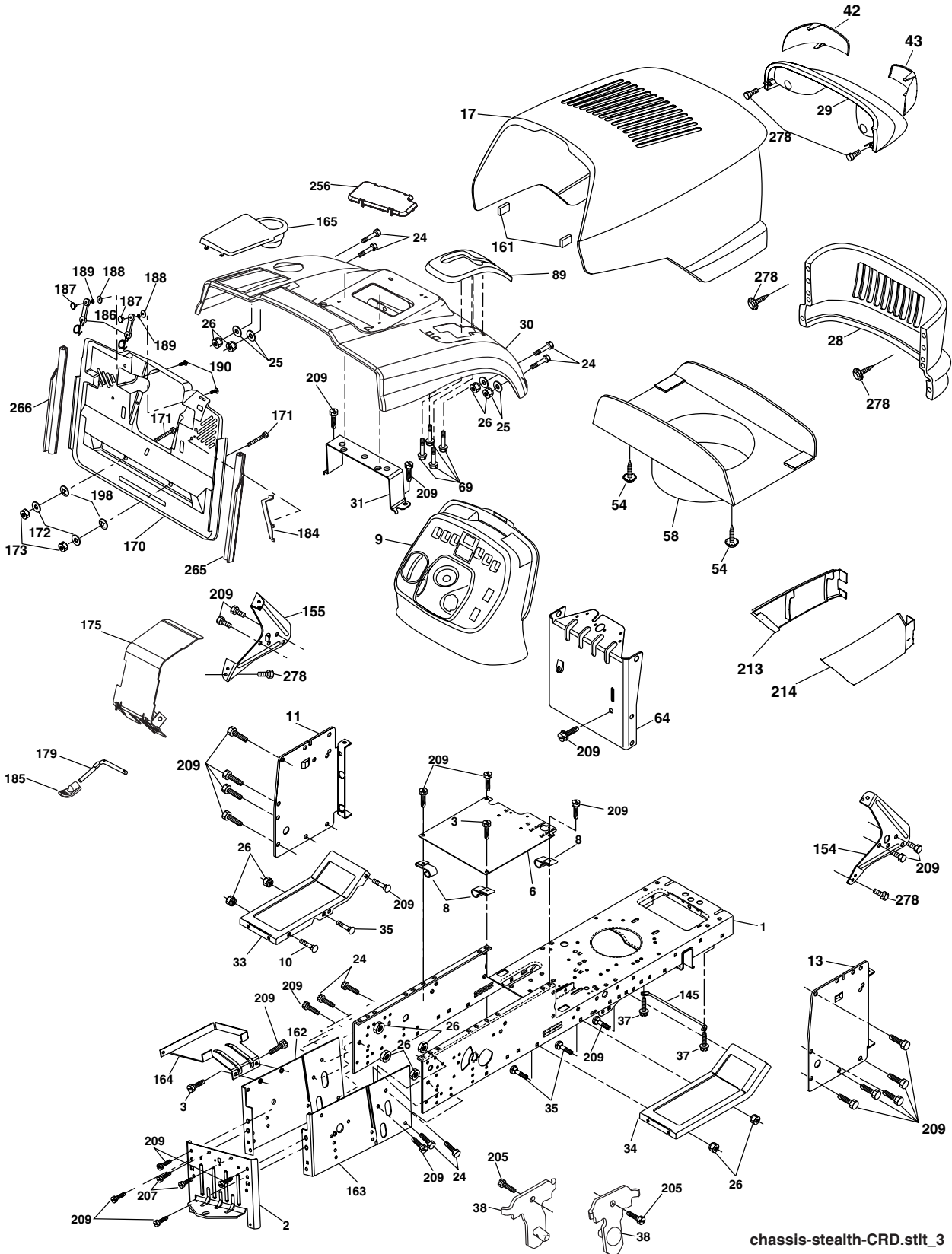

chassis-stealth-CRD.stlt\_3

# REPAIR PARTS

TRACTOR- -MODEL NO. BM18H107RB (96061003200), PRODUCT NO. 960 61 00-32  
CHASSIS AND ENCLOSURES

KEY NO.	PART NO.	DESCRIPTION	KEY NO.	PART NO.	DESCRIPTION
1	532 17 46-20	Chassis	161	532 16 46-55	Bumper Extrusion
2	532 18 03-84	Drawbar	162	532 18 03-82	Bracket Exten Chassis Lh CRD
3	817 06 06-12	Screw 3/8-16 x 3/4	163	532 18 03-83	Bracket Exten Chassis Rh CRD
6	532 18 44-19	Saddle	164	532 16 56-05	Support Battery CRD
8	532 12 64-71	Clip Insulator 13/32 Mtg. Hole	165	532 18 13-56	Cover Battery
9	532 19 49-75	Dash	170	532 17 88-62	Backplate Asm CRD
10	872 14 06-08	Bolt, Carriage 3/8-16 x 3/4	171	872 14 06-20	Bolt Rdhd Sqnk 3/8-16 x 2-1/2 Gr. 5
11	532 16 72-03	Panel, Dash, L.H.	172	819 13 20-16	Washer 13/32 x 1-1/4 x 16 Ga.
13	532 17 82-98	Panel, Asm. Dash R.H.	173	873 51 06-00	Nut, Keps Hex 3/8-16 unc
17	532 19 51-04	Hood	175	532 18 82-03	Door Trap
24	874 78 06-16	Bolt	179	532 18 82-02	Rod Pivot
25	819 13 13-12	Washer 13/32 x 13/16 x 12 Ga.	184	532 17 46-62	Bracket Actuator Bagger CRD
26	873 80 06-00	Nut	185	532 18 11-01	Knob Rod Brake Parking
28	532 18 71-14	Grille	186	532 16 07-93	Latch Asm Mulch/Bagger
29	532 17 97-63	Light Asm Dual	187	532 00 20-29	Nut Weld
30	532 19 24-69	Fender	188	819 06 12-16	Washer #10
31	532 16 51-56	Bracket, Fender Support	189	810 07 10-00	Washer Lock #10
33	532 18 64-57	Footrest, L.H.	190	871 08 10-10	Screw Pan Hd Phillip 10-24 x 5/8
34	532 18 64-58	Footrest, R.H.	198	532 16 89-37	Nut, Push
35	872 11 06-06	Bolt	205	817 49 06-08	Screw Thdrol 3/8-16 x 1/2
37	817 49 05-08	Screw Thdrol 5/16-18 x 1/2 TYT	207	817 67 05-08	Screw Thdrol 5/16-18 x 1/2
38	532 18 17-48	Bracket Asm Pivot Mower Rear	209	817 00 06-12	Screw Hex Wsh Thdrol 3/8-16
42	532 16 18-41	Lens LH	213	532 18 71-12	Skirt Grille LH
43	532 16 18-42	Lens RH	214	532 18 71-11	Skirt Grille RH
54	532 19 25-12	Screw WSHD Hex 10-32 x 5/8	256	532 18 13-61	Cover Fender Rack CRD
58	<b>532 17 53-51</b>	Duct Air Engine	265	532 18 57-04	Seal RH Side Bagger
64	532 18 43-40	Bracket Dash Lower	266	532 18 57-03	Seal LH Side Bagger
69	532 14 24-32	Screw Hex Wsh	278	532 19 16-11	Screw 10 x 3/4 Single Lead Hex
89	532 18 13-60	Console	--	532 19 39-35	Plug Switch Light
145	532 15 65-24	Rod Pivot Chassis/Hood			
154	532 18 39-25	Bracket Dash RH			
155	532 18 39-26	Bracket Dash LH			

**NOTE:** All component dimensions given in U.S. inches.  
1 inch = 25.4 mm.





# REPAIR PARTS

**TRACTOR- -MODEL NO. BM18H107RB (96061003200), PRODUCT NO. 960 61 00-32  
DRIVE**

KEY NO.	PART NO.	DESCRIPTION	KEY NO.	PART NO.	DESCRIPTION
1	-----	Transaxle Hydro Gear 321-0510 (Order parts from transaxle manufacturer)	84	532 17 00-07	Link, Transaxle
8	532 16 56-19	Rod, Shift Fender Adjust Lt	95	532 17 00-15	Control Asm Bypass Hydro
9	532 18 02-20	Clutch Electric	96	532 12 47-88	Spring, Retainer 1"
10	876 02 04-16	Pin, Cotter 1/8 x 1	112	819 09 12-10	Washer 9/32 x 3/4 x 10 Ga.
14	810 04 04-00	Washer, Lock Hvy Helical	116	872 14 06-08	Bolt RDHD SQNK 3/8-16 x 1
16	873 80 05-00	Nut, Lock Hex w/Ins 5/16-18 unc	120	873 90 06-00	Nut Lock Flg. 3/8-16 unc
17	532 12 61-97	Washer 1-1/2 OD x 15/32 ID x .250	145	874 49 05-44	Bolt Hex FGHD 5/16-18 x Gr. 5
19	873 80 06-00	Nut Lock 3/8-16 unc	150	532 16 58-50	Bushing, Bellcrank Grnd Dr
20	532 17 39-37	Bolt, Hex 7/16-20 x 4	151	819 13 32-10	Washer 13/32 x 2 x 10 Ga.
21	532 10 69-33	Knob	156	532 16 60-02	Washer Srrted 5/16 ID x 1.125
22	532 17 56-07	Rod, Brake	158	532 16 55-89	Bracket Shift Mount
24	873 35 06-00	Nut	159	532 18 39-00	Hub Tapered Flange Shift Lt
25	532 19 20-36	Spring, Rod, Brake	161	872 14 04-06	Bolt Rdhd Sqnk 1/4-20 x 3/4 Gr. 5
26	819 13 13-16	Washer 13/32 x 7/8 x 16 Ga.	162	873 68 04-00	Nut Crownlock 1/4-20 unc
27	876 02 04-12	Pin, Cotter 1/8 x 3/4	163	874 78 04-16	Bolt Hex Fin 1/4-20 unc x 1 Gr. 5
28	532 17 57-65	Rod, Parking Brake	165	532 16 56-23	Bracket Pivot Lever
29	532 07 16-73	Cap, Parking Brake	166	817 49 05-10	Screw 5/16-18 x 5/8
30	532 16 95-92	Bracket, Mfg. Transaxle	167	532 16 55-88	Bracket Support Shift CRD
34	532 17 55-78	Shaft, Asm Pedal Foot CRD	168	532 16 54-92	Bolt Shoulder 5/16-18 x .561
35	532 12 01-83	Bearing, Nylon	169	532 16 55-80	Plate Fastening Lt
36	819 21 16-16	Washer 21/32 x 1 x 16 Ga.	171	817 49 06-08	Screw Thdrol 3/8-16 x 1/2 Ty-Tt
37	532 12 49-63	Pin, Roll 3/16 x 1"	172	532 17 02-71	Shaft Asm Shifter Frt CRD
38	532 16 59-36	Pulley Flat Composite 3.06"	177	532 16 59-32	Keeper Flat Idler 3.06" CRD
39	874 76 06-44	Bolt Fin Hex 3/8-16 unc x 2-3/4	178	532 16 59-33	Keeper Belt Idler 1.88" CRD
40	532 12 49-65	Spacer, Split 395 x 59 Bzp	179	532 12 09-58	Washer Sintered
42	819 13 13-12	Washer 13/32 x 13/16 x 12 Ga.	180	532 16 56-30	Pulley, Idler, Flat 1.88"CRD
43	819 11 10-12	Washer 11/32 x 5/8 x 12 Ga.	181	532 18 02-11	Bracket Idler Ground Drive CRD
47	532 12 77-83	Pulley, Idler, V Groove Plastic	182	532 18 26-82	Keeper Belt 2.5" Od V-Idler CRD
48	532 15 44-07	Bellcrank Clutch Grnd Drv	183	532 18 60-07	Pulley V-Idler CRD
49	532 12 32-05	Retainer, Belt Style Spring	184	817 49 06-44	Screw Hexwsh Thdrol 3/8-16 x 2-3/4
50	872 11 06-12	Bolt Carr SH 3/8-16 x 1-1/2 Gr. 5	185	532 17 00-08	Link Shift
51	873 68 06-00	Nut, Crownlock 3/8-16 unc	186	532 16 56-14	Hub Tapered Round CRD
52	873 68 05-00	Nut Crownlock 5/16-18	187	817 58 05-20	Screw Thdrol 5/16-18 x 1.25
53	532 10 57-10	Link, Clutch 7.66	197	532 16 96-13	Nyliner Snap-In 5/8
55	532 10 57-09	Spring, Return, Clutch	199	532 16 96-12	Bolt Shoulder 5/16-18 unc
56	817 06 06-20	Screw 3/8-16 x 1-1/4	200	872 14 05-08	Bolt RDHD SQNK 5/16-18 x 1
57	532 17 01-40	V-Belt Kev 112" 0650 CRD	202	872 11 06-14	Bolt Carr. Sh. 3/8-16 x 1-3/4 Gr. 5
62	532 12 48-72	Cover, Pedal	207	532 16 98-45	Washer Nylon Rear
63	532 18 03-97	Pulley, Engine	214	532 17 56-09	Shaft Asm. Brake
65	810 04 07-00	Washer	215	532 17 56-52	Rod Brake Hydro
66	532 15 47-78	Keeper, Belt Engine F-Proof	243	532 19 07-36	Bracket Anti-Rotation
71	532 16 91-83	Strap, Torque, Lh	254	817 00 06-16	Screw 3/8-16 x 1
73	532 16 91-82	Strap, Torque, Rh	255	532 17 56-08	Brace Shaft Brake Mtg.
74	532 13 70-57	Spacer, Split	258	532 17 80-62	Clip Retainer
75	532 12 17-49	Washer 25/32 x 1-1/4 x 16 Ga.	259	532 18 02-12	Bracket Pulley IDL Hydro Grd. Dr.
76	812 00 00-01	Ring, E	260	532 18 17-81	Bracket Idler Chassis
77	532 12 35-83	Key, Square	261	532 13 14-94	Pulley Idler flat
78	532 12 17-48	Washer 25/32 x 1-5/8 x 16 Ga.	263	817 00 06-12	Screw HXWSH THDROL 3/8-16 x 3/4 Blk
81	532 17 00-06	Asm, Shaft			
82	532 16 57-11	Spring, Torsion			
83	819 17 12-16	Washer 17/32 x 3/4 x 16 Ga.			

**NOTE:** All component dimensions given in U.S. inches  
1 inch = 25.4 mm

# REPAIR PARTS

TRACTOR- -MODEL NO. BM18H107RB (96061003200), PRODUCT NO. 960 61 00-32  
STEERING ASSEMBLY

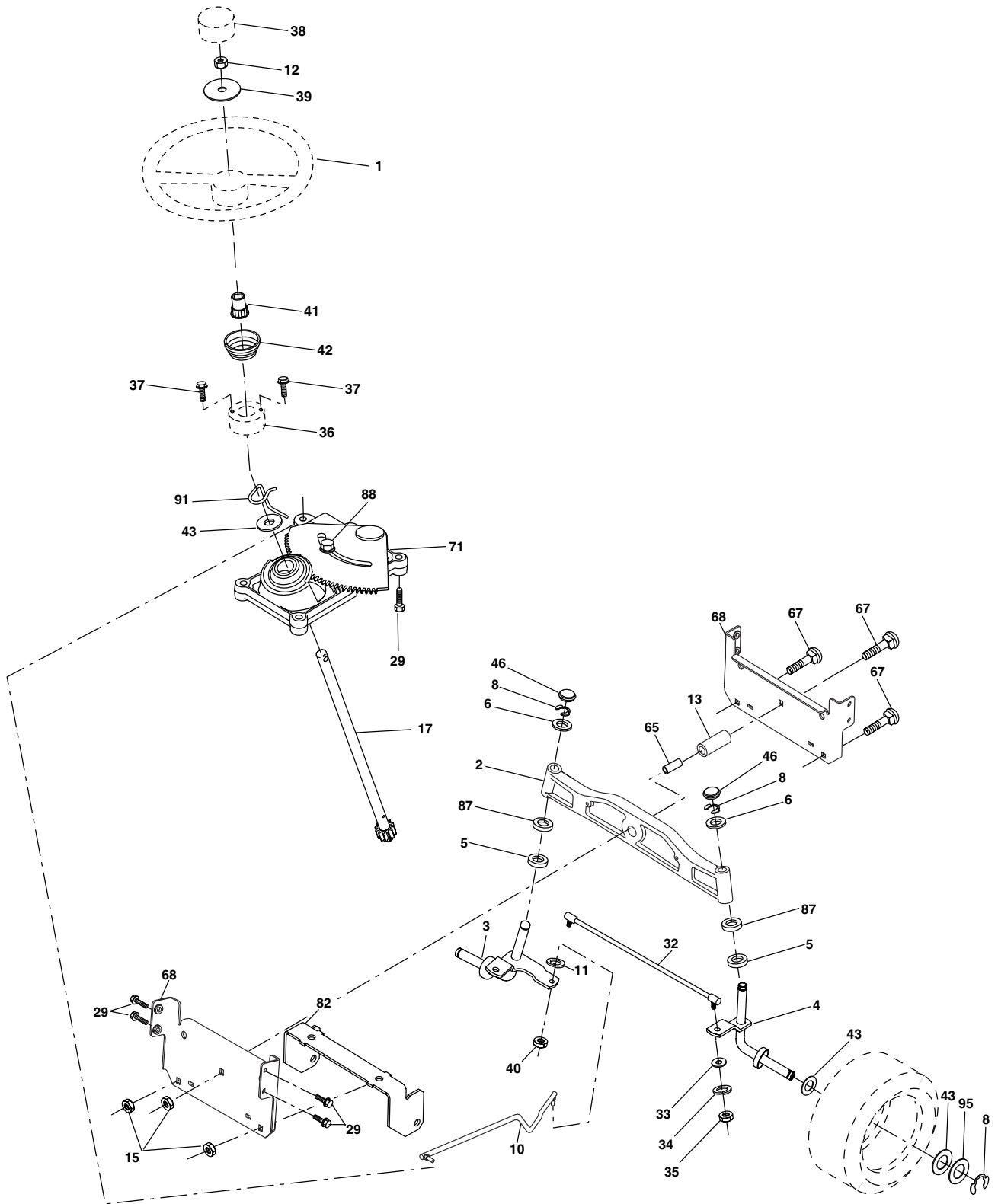

steering\_stealth\_prem\_11

# REPAIR PARTS

TRACTOR- -MODEL NO. BM18H107RB (96061003200), PRODUCT NO. 960 61 00-32  
STEERING ASSEMBLY

KEY NO.	PART NO.	DESCRIPTION
1	532 19 46-37	Steering Wheel
2	532 18 47-06	Front Axle Assembly
3	532 16 98-40	Spindle Assembly, L.H.
4	532 16 98-39	Spindle Assembly, R.H.
5	532 12 49-31	Bearing, Race, Thrust, Hardened
6	532 12 17-48	Washer 25/32 x 1-5/8 x 16 Ga.
8	812 00 00-29	Ring, Klip
10	532 17 51-21	Link, Drag
11	810 04 06-00	Washer, Lock
12	873 94 08-00	Nut Hex Jam Toplock 1/2-20 unf
13	532 13 65-18	Spacer Axle
15	532 14 52-12	Nut Hex Flange Lock
17	532 17 78-83	Shaft Assembly, Steering
29	817 00 06-12	Screw 3/8-16 x 3/4
32	532 17 18-88	Rod, Tie
33	819 11 12-16	Washer 11/32 x 3/4 x 16 Ga.
34	810 04 05-00	Washer Lock Hvy Hlcl Spr 5/16
35	873 54 05-00	Crownlock Nut 5/16-24 unf
36	532 14 52-07	Bushing, Steering
37	532 15 29-27	Screw TT #10-32 x 5 x 3/8 Flange
38	532 19 46-03	Cap Wheel Steer
39	819 18 38-12	Washer 9/16 ID x 2-3/8 OD 12 Ga.
40	873 54 06-00	Nut Crownlock 3/8-24
41	532 18 67-37	Adaptor, Steering Wheel
42	532 17 71-49	Boot, Steering Dash
43	532 12 17-49	Washer 25/32 x 1-1/4 x 16 Ga.
44	532 18 06-40	Extension Steering
46	532 12 12-32	Cap, Spindle
65	532 16 03-67	Spacer Axle
67	872 11 06-18	Bolt Rdhd Sq 3/8-16 x 2-1/4
68	532 16 98-27	Brace Axle
71	532 17 51-46	Steering Asm.
73	532 18 14-49	Extension, Steering
82	532 16 98-35	Bracket Susp. Chassis Front
87	532 17 39-66	Washer Flat .781 x 1-1/2 x .14
88	532 17 51-18	Bolt Shoulder 7/16-20 unc
91	532 17 55-53	Clip Steering
95	532 18 89-67	Washer Hardened

**NOTE:** All component dimensions given in U.S. inches.  
1 inch = 25.4 mm.

# REPAIR PARTS

TRACTOR- -MODEL NO. BM18H107RB (96061003200), PRODUCT NO. 960 61 00-32  
SEAT ASSEMBLY

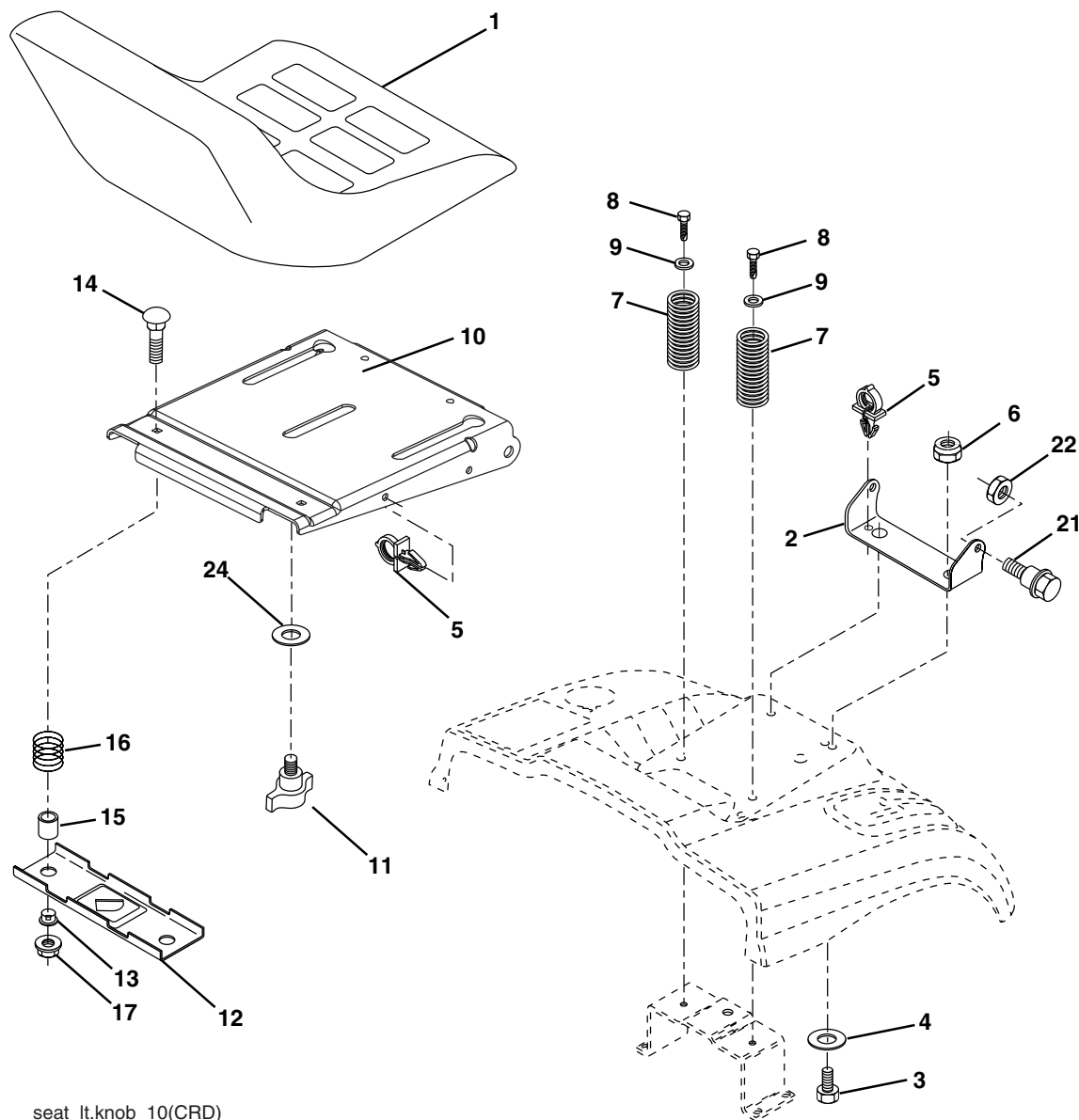

seat\_lt.knob\_10(CRD)

KEY NO.	PART NO.	DESCRIPTION	KEY NO.	PART NO.	DESCRIPTION
1	532 18 87-06	Seat	12	532 12 12-46	Bracket Pnt Mounting Switch
2	532 18 01-66	Bracket Pivot Seat	13	532 12 12-48	Bushing Snap Blk Nyl 50 Id
3	871 11 06-16	Bolt Fin Hex 3/8-16 x 1 Blk	14	872 05 04-12	Bolt Rdhd Sht Nk 1/4-20 x 1-1/2
4	819 13 16-10	Washer Flat 13/32 x 1 x 10 Ga.	15	532 12 12-49	Spacer Split
5	532 14 50-06	Clip Push In Hinged	16	532 12 37-40	Spring Cprsn
6	873 80 06-00	Nut Lock Hex w/Insert 3/8-16	17	532 12 39-76	Nut Lock 1/4 Lge Flg Gr. 5 Zinc
7	532 12 41-81	Spring Seat Cprsn 2 250 Blk Zi	21	532 17 18-52	Bolt Shoulder 5/16-18 unc-2A
8	817 00 06-16	Screw 3/8-16 x 1.5	22	873 80 05-00	Nut Hex Lock w/Ins 5/16-18
9	819 13 16-14	Washer 13/32 x 1 x 14 Ga.			
10	532 18 01-86	Pan Seat			
11	532 16 63-69	Knob Seat Adj. Wingnut			

**NOTE:** All component dimensions given in U.S. inches.  
1 inch = 25.4 mm

# REPAIR PARTS

TRACTOR- -MODEL NO. BM18H107RB (96061003200), PRODUCT NO. 960 61 00-32  
DECALS

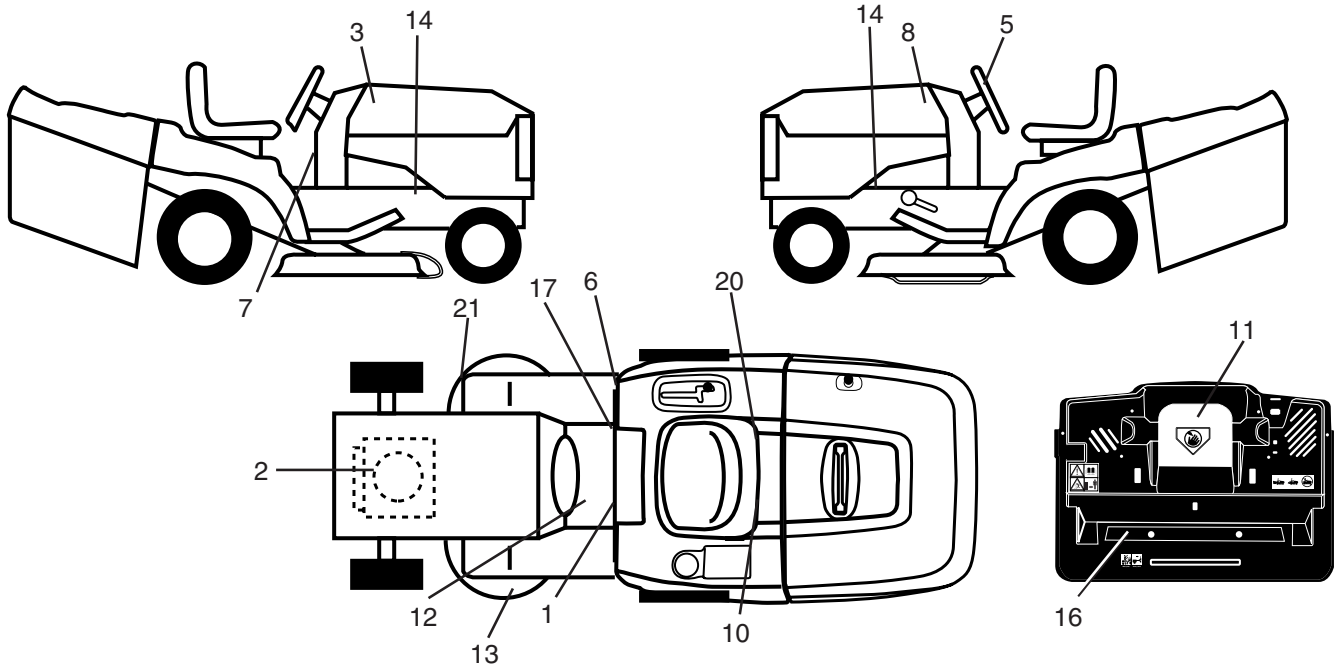

KEY NO.	PART NO.	DESCRIPTION
1	532 14 54-98	Decal Read Owner's Manual Sym
2	532 18 95-25	Decal Hp Engine
3	532 19 44-24	Decal Hood RH
5	532 19 44-19	Decal Wheel Steering
6	532 18 04-32	Decal 100 DB/CE
8	532 19 44-25	Decal Hood LH
10	532 14 50-05	Decal Bat Dan/Poi P/L Sym Wpn
11	532 18 21-66	Decal Mower Cut Finger Symbol
12	532 15 97-37	Decal Brake/Clutch Symbol Lt
13	532 18 78-11	Decal Deck Enviro
14	532 15 97-36	Decal Chassis Hot Muffler

KEY NO.	PART NO.	DESCRIPTION
16	532 18 04-35	Decal Backplate
17	532 14 08-37	Decal Saddle Brake Parking
20	532 16 69-60	Decal Bypass Fender CRD
21	532 16 62-86	Decal Hex Belt Sch 92 CRD
—	532 18 26-21	Decal Bagger Frame
—	532 18 10-90	Pad Footrest RH
—	532 18 10-91	Pad Footrest LH
—	532 19-44-93	Manual Operator's (Euro)
—	532 19 44-94	Manual Operator's (Port)
—	532 19 44-95	Manual Operator's (Polish)
—	532 19 44-96	Manual Manual Parts

## WHEELS & TIRES

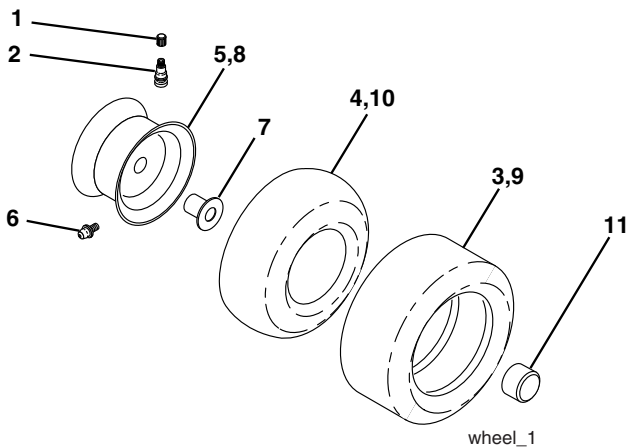

KEY NO.	PART NO.	DESCRIPTION
1	532 05 91-92	Cap Value Tire
2	532 06 51-39	Stem Value
3	532 10 62-22	Tire F Ts 15 x 6 0 - 6 Service
4	532 05 99-04	Tube Inner Front #35060
5	532 13 83-36	Rim Asm 6" front Service
6	532 12 49-57	Fitting Grease
7	532 12 49-59	Bearing Flange
8	532 13 83-37	Rim Asm 8" rear Silver Service
9	532 13 84-68	Tire R Ts 20 x 8-8 Service
10	532 12 49-26	Tube Rear 9 5 x 8 Service
11	532 17 50-39	Cap Axle
--	532 14 43-34	Sealant, Tire (10 oz. tube)

**NOTE:** All component dimensions given in U.S. inches  
1 inch = 25.4 mm

# REPAIR PARTS

TRACTOR- -MODEL NO. BM18H107RB (96061003200), PRODUCT NO. 960 61 00-32  
ENGINE

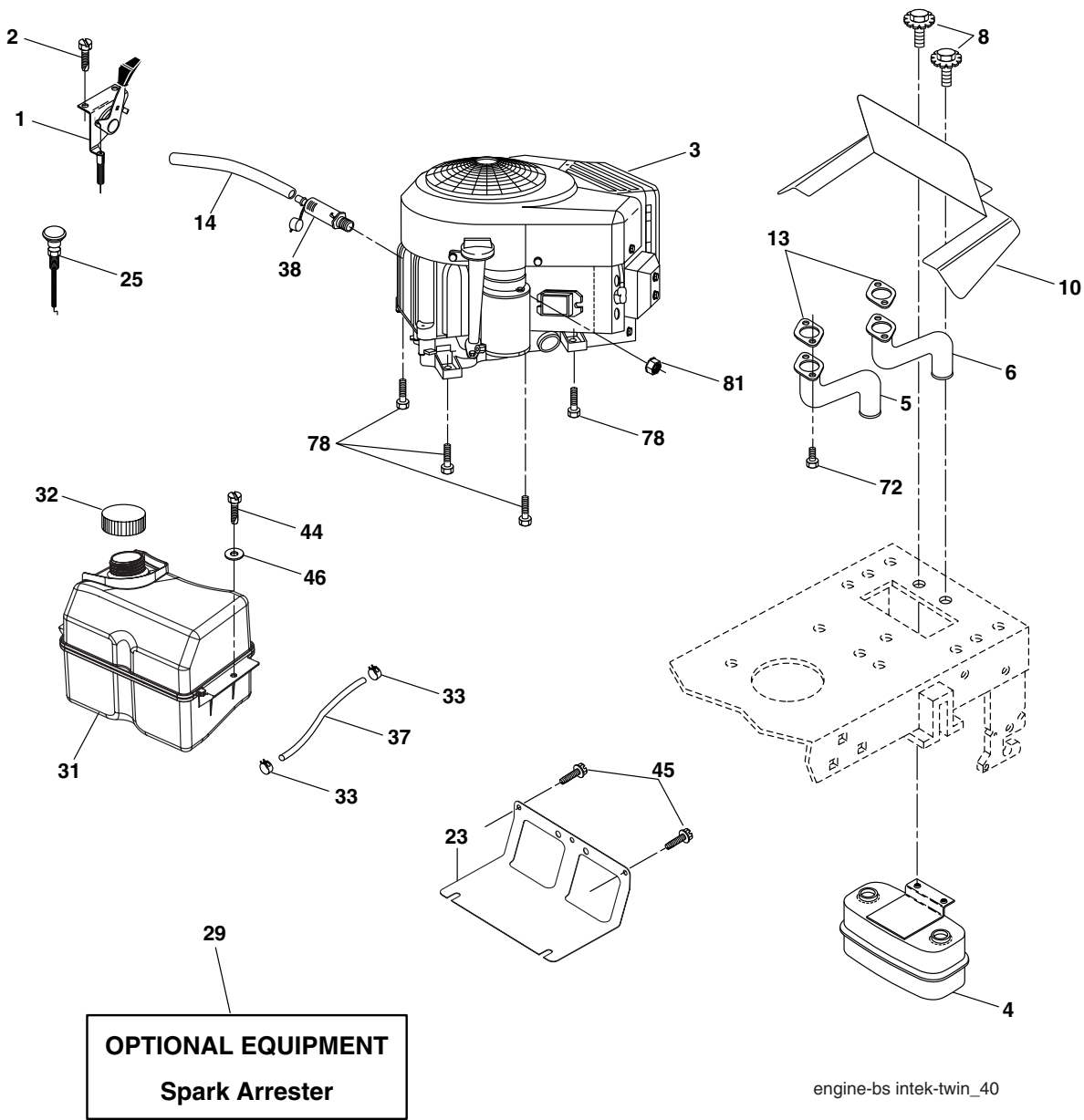

KEY NO.	PART NO.	DESCRIPTION
1	532 17 83-85	Control Throttle
2	532 19 16-11	Screw 10 x 3/4 Single Lead Hex
3	-----	Engine Briggs 406577 (Order parts from engine manufacturer)
4	532 14 97-23	Muffler Twin Lo-Twin
5	532 15 99-55	Tube, Exhaust Lh
6	532 16 05-89	Tube, Exhaust Rh
8	532 17 18-77	Bolt 5/16-18 unc x 3/4 w/Sems
10	532 16 27-97	Shield Browning Intek
13	532 16 53-91	Gasket Muffler
14	532 14 84-56	Tube Drain Oil Easy
17	817 06 06-24	Screw 3/8-16 x 1-1/2
23	532 16 98-37	Shield Brn/Dbr Guard
25	532 19 15-96	Choke Control

KEY NO.	PART NO.	DESCRIPTION
29	532 13 71-80	Kit Spark Arrestor (Flat Scrn)
31	532 18 55-34	Tank Fuel 2.00
32	532 14 05-27	Cap Asm Fuel W/sym Vented
33	532 12 34-87	Clamp Hose Blk
37	532 13 70-40	Line Fuel
38	532 18 16-54	Plug Drain Oil Easy
44	817 67 04-12	Screw Hexwsh Thdrol 1/4-20 x 3/4
45	817 00 06-12	Screw Hexwsh Thdrol 3/8-16 x 3/4
46	819 09 14-16	Washer 9/32 x 7/8 x 16 Ga.
72	532 18 39-06	Screw Socket Head 5/16-18 x 1
81	873 51 04-00	Nut Keps Hex 1/4-20 unc

**NOTE:** All component dimensions given in U.S. inches  
1 inch = 25.4 mm

# REPAIR PARTS

TRACTOR- -MODEL NO. BM18H107RB (96061003200), PRODUCT NO. 960 61 00-32  
MOWER LIFT

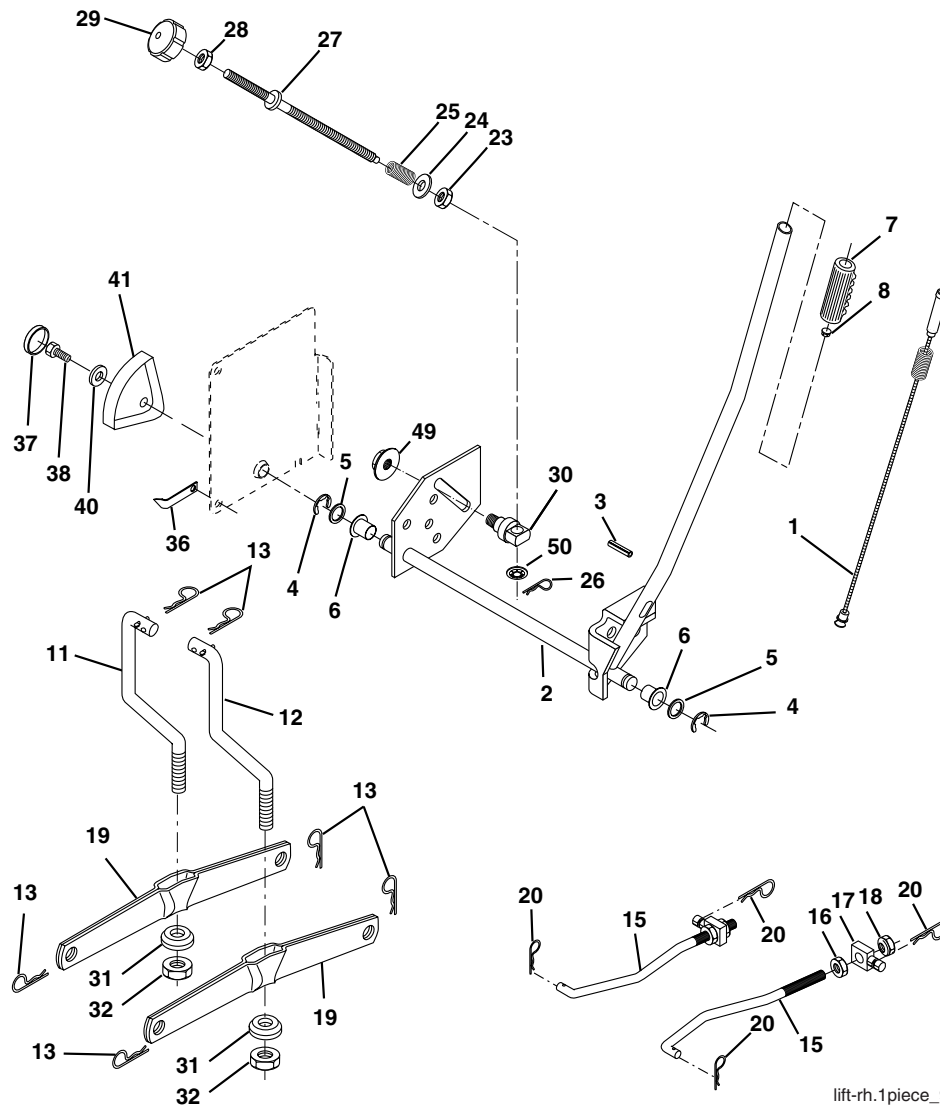

lift-rh.1piece\_9

KEY NO.	PART NO.	DESCRIPTION	KEY NO.	PART NO.	DESCRIPTION
1	532 15 94-61	Washer Asm Inner Spring W/ Plunger	24	819 13 10-16	Washer 13/32 x 5/8 x 16 Ga.
2	532 15 94-76	Shaft Asm. Lift	25	532 13 71-50	Spring Compression Inf Hgt
3	532 18 88-22	Pin Groove	26	532 16 94-84	Retainer Clip
4	812 00 00-02	E Ring #5133-62	27	532 13 71-67	Rod Adj Lift
5	819 21 16-21	Washer 21/32 x 1 x 21 Ga.	28	873 35 06-00	Nut Hex Jam 3/8-16 unc
6	532 12 01-83	Bearing Nylon	29	532 13 80-57	Knob Inf 3/8-16 unc Blk w/sym
7	532 10 94-13	Grip Handle	30	532 15 02-33	Trunnion Infin Height
8	532 12 45-26	Button Plunger Black	31	532 16 98-65	Bearing, Pvt. Lift.
11	532 16 58-29	Link Asm Lift L.H.	32	873 54 06-00	Nut Crownlock 3/8-24
12	532 16 58-31	Link Asm Lift R.H.	36	532 15 50-97	Pointer Height Indicator
13	532 12 46-70	Retainer Spring	37	532 12 39-35	Plug Hole Blk 1.485/1.515 Dia
15	532 17 32-88	Link Front	38	817 06 05-16	Screw 5/16-18 x 1
16	873 35 08-00	Nut Jam Hex 1/2-13 unc	40	819 11 24-10	Washer 11/32 x 1-1/2 x 10 Ga.
17	532 17 56-89	Trunnion Blk Zinc	41	532 12 39-34	Scale Ind Height Blk
18	873 80 08-00	Nut Lock w/wsh 1/2-13 unc	49	532 14 52-12	Nut hex Flange Lock
19	532 13 98-68	Arm Suspension Mower	50	532 11 04-52	Nut Push Phos & Oil
20	532 16 35-52	Retainer Spring			
23	532 11 08-07	Nut Special			

**NOTE:** All component dimensions given in U.S. inches  
1 inch = 25.4 mm



# REPAIR PARTS

TRACTOR- -MODEL NO. BM18H107RB (96061003200), PRODUCT NO. 960 61 00-32  
MOWER

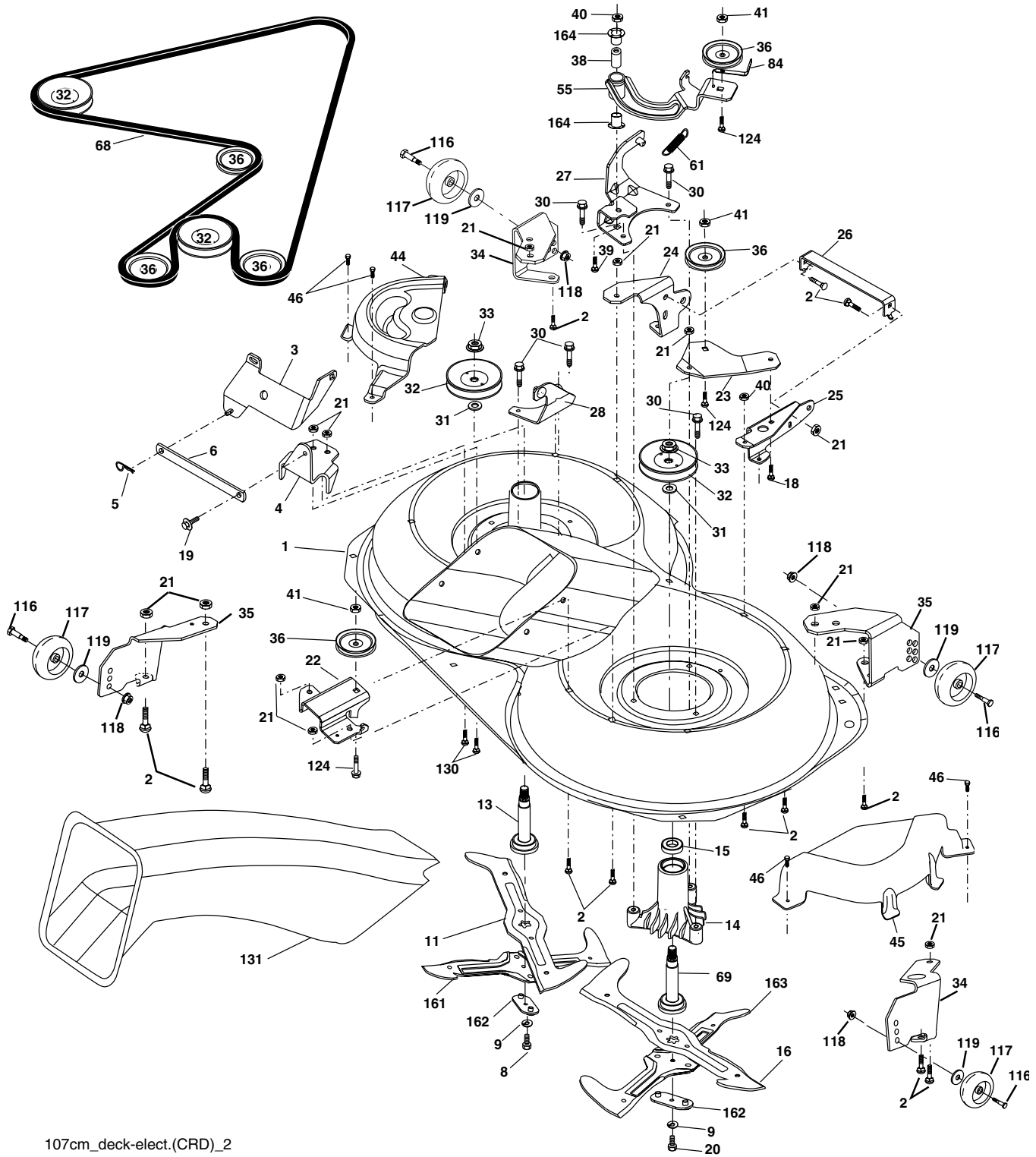

107cm\_deck-elect.(CRD)\_2



# REPAIR PARTS

TRACTOR- -MODEL NO. BM18H107RB (96061003200), PRODUCT NO. 960 61 00-32  
MOWER

KEY NO.	PART NO.	DESCRIPTION	KEY NO.	PART NO.	DESCRIPTION
1	532 16 91-60	Housing Asm. Mower	38	532 16 98-51	Spacer Hub Arm Idler
2	872 14 05-06	Bolt Rdhd Sqnk 5/16-18 unc x 3/4	39	872 11 06-22	Bolt RhHd 3/8-16 unc x 2-3/4 Gr. 5
3	532 16 55-69	Bracket Asm. S-Bar Chass	40	873 90 06-00	Nut lock 3/8-16 unc
4	532 16 91-67	Bracket Bar Sway Deck	44	532 17 55-38	Cover Mandrel Lh
5	532 12 46-70	Retainer Spring	45	532 17 55-39	Cover Mandrel Rh
6	532 16 55-57	Bar Sway	46	532 13 77-29	Screw Thd Roll 1/4-20 x 5/8
8	532 18 17-12	Bolt 3/8-24 x 1.25 Gr. 8 Patched	55	532 16 98-49	Arm Idler
9	810 03 06-00	Washer Lock Hvy 3/8 Unplated	61	532 17 51-59	Spring Tension Belt
11	532 18 05-83	Blade 3-1 Lh	68	532 16 91-78	Hex-Belt Mower
13	532 13 76-45	Shaft Asm. W/Lower Bearing	69	532 16 54-82	Shaft Asm W/Lwr Brg Rh Thd CRD
14	532 12 87-74	Housing Mandrel Vented (Machd)	84	532 15 60-85	Keeper Belt Idler
15	532 11 04-85	Bearing Ball Mandrel	116	532 18 42-19	Bolt Shoulder
16	532 18 05-84	Blade 3-1 Rh	117	532 17 48-73	Wheel Gage
18	872 11 06-06	Bolt RDHD SHT SQNK 3/8-16 x 3/4	118	873 93 06-00	Nut Centerlock 3/8-16 unc
19	532 13 28-27	Bolt Shoulder 5/16-18 Thd Form	119	819 12 14-14	Washer 3/8 x 7/8 x 14 Ga.
20	532 18 17-13	Bolt 3/8-24 x 1.25 Gr. 8 Ptch Lhthd	124	872 11 06-12	Bolt Carr Sh 3/8-16 x 1-1/2 Gr. 5
21	873 68 05-00	Nut Crown Lock 5/16-18	130	872 11 05-06	Bolt Rdhdsqnk 5/16-18 unc x 3/4
22	532 16 91-65	Bracket Idler Sprt RR	131	532 16 56-61	Chute Bagger CRD 92cm
23	532 16 91-66	Bracket Idler Sprt RF	161	532 18 04-24	Blade Cross LH 107
24	532 16 91-70	Bracket Suspension LF	162	532 18 08-78	Adapter Weldment Blade 107
25	532 16 91-71	Bracket Suspension RF	163	532 18 04-25	Blade Cross RH 107
26	532 16 52-37	Brace Support Susp Frt CRD	164	532 00 33-66	Bearing
27	532 16 91-72	Bracket Asm. Susp RR	--	532 18 18-57	Mandrel Asm Service
28	532 16 91-68	Bracket Asm. Susp LR	--	532 18 18-58	Mandrel Asm CRD Lh Threads VC
30	532 17 39-84	Screw Thd Rolling Dod.PT Hex	--	532 18 17-70	Replacement Mower Complete (Std. Deck - Order separately gauge wheel components key nos. 116-119)
31	532 18 76-90	Washer Spacer Mandrel			
32	532 17 57-07	Mandrel Pulleys			
33	532 17 83-42	Nut Flg Top Lock			
34	532 17 95-09	Bracket Gauge Wheel Lf			
35	532 17 62-92	Bracket Gauge Wheel Rf			
36	532 14 67-63	Pulley Idler V-Groove Dim 4.25			

**NOTE:** All component dimensions given in U.S. inches  
1 inch = 25.4 mm

# REPAIR PARTS

TRACTOR- -MODEL NO. BM18H107RB (96061003200), PRODUCT NO. 960 61 00-32  
BAGGER

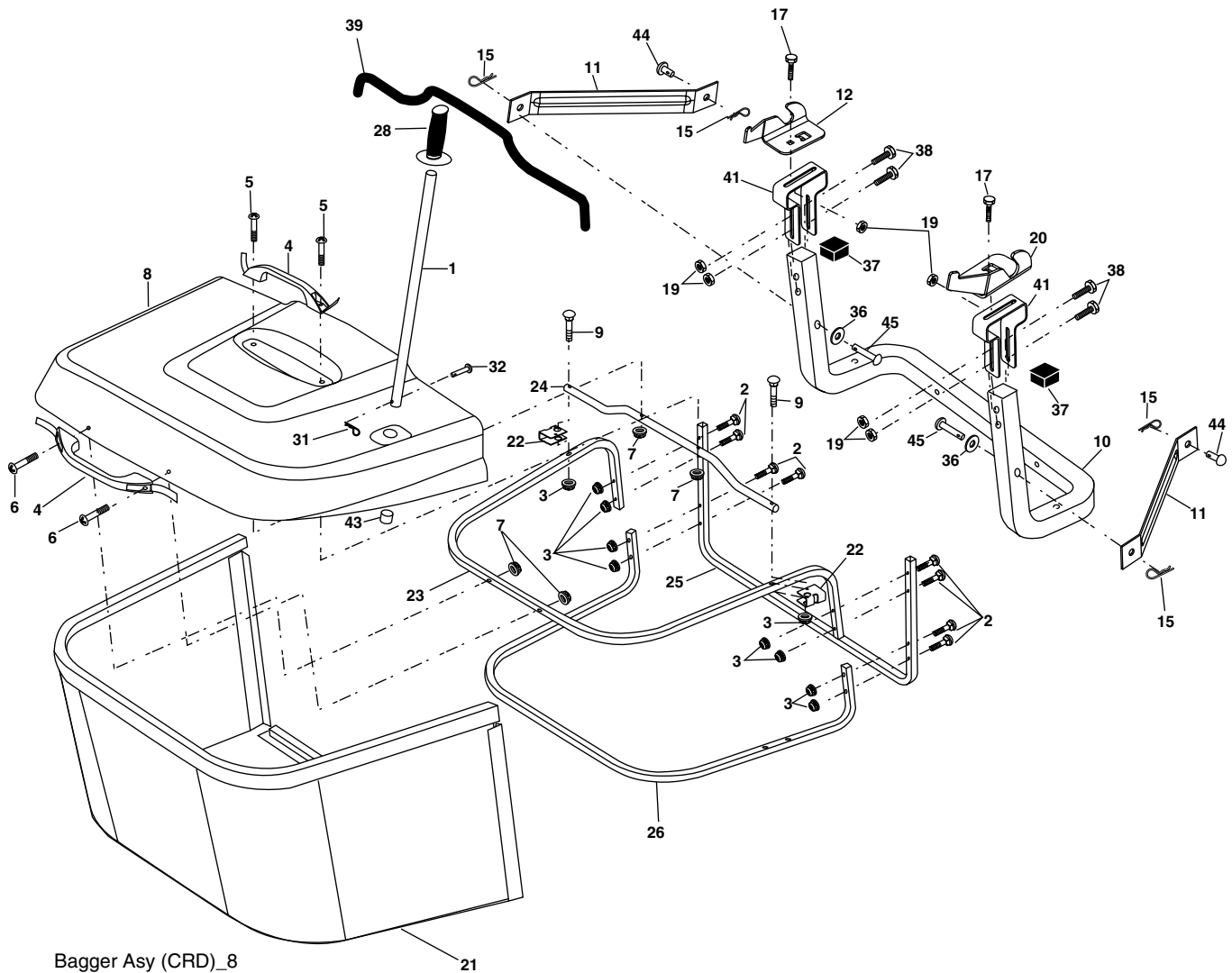

Bagger Asy (CRD)\_8

KEY NO.	PART NO.	DESCRIPTION	KEY NO.	PART NO.	DESCRIPTION
1	532 16 52-49	Tube Handle Bagger CRD	26	532 16 57-85	Tube Lower Bagger CRD
2	872 14 04-16	Bolt Carriage 1/4-20 x 2.0 Gr. 5	28	532 16 57-87	Grip Handle Black
3	532 12 39-76	Nut Lock 1/4 Lge Flg Gr. 5 Zinc	31	532 16 94-84	Retainer Clip
4	532 16 99-16	Handle Bagger w/Lvrs Blk CRD	32	532 12 68-75	Rivet Rd Hd Drilled 3/8 Dia
5	874 98 10-24	Screw Pan Head #10-24 x 1.50 Blk	33	532 16 93-80	Plug Mulch
6	874 98 10-32	Screw Pan Hd	34	532 16 55-70	Handle Mulcher
7	873 40 10-00	Nut Wiz Lock Hex Serr/Hd 10-24	35	532 16 55-72	Pin Mulcher
8	532 19 24-70	Cover Bagger	36	819 13 20-16	Washer 13/32 x 1-1/4 x 16 Ga.
9	872 14 04-18	Bolt Carriage 1/4-20 x 2.25d x Gr.5	37	532 17 54-01	Plug Support Bagger CRD
10	532 18 12-82	Tube Support Bagger CRD	38	872 01 05-20	Bolt 5/16-18 x 2-1/2
11	532 16 57-19	Bracket Support Upper Bag CRD	39	532 18 09-85	Seal Trim
12	532 18 88-48	Bracket Pivot LH	41	532 16 96-83	Bracket Pnt Adj Pvt Bagger CRD
15	532 12 46-70	Retainer Spring	42	873 80 05-00	Nut Crownlock 5/16-18 Blk D
17	872 14 05-06	Bolt Rdhd Sht Sqnk 5/16 -18 unc x 3/4	43	532 17 40-83	Plug Tubing End
20	532 18 88-47	Bracket Pivot RH	44	532 19 33-12	Pin Clevis 3/8 x 11/16
21	532 18 08-80	Bag Asm CRD	45	532 19 33-13	Pin Clevis 3/8 x 2.00
22	532 16 57-81	Bracket Side Bagger CRD			
23	532 16 57-82	Tube Upper Bagger CRD			
24	532 16 57-83	Tube Pivot Bagger CRD			
25	532 18 01-24	Tube Front Bagger CRD			

**NOTE:** All component dimensions given in U.S. inches  
1 inch = 25.4 mm



***BESTGREEN***