

ILLUSTRATED PARTS BREAKDOWN

MAC ALLISTER

15.5 HP 107 LAWN TRACTOR

MODEL NO. MAC 15107-AP (MA15542RA)

964 77 43-00

REPAIR PARTS

TRACTOR- -MODEL NO. MAC 15107-AP (MA15542RA), PRODUCT 964 77 43-00
ELECTRICAL

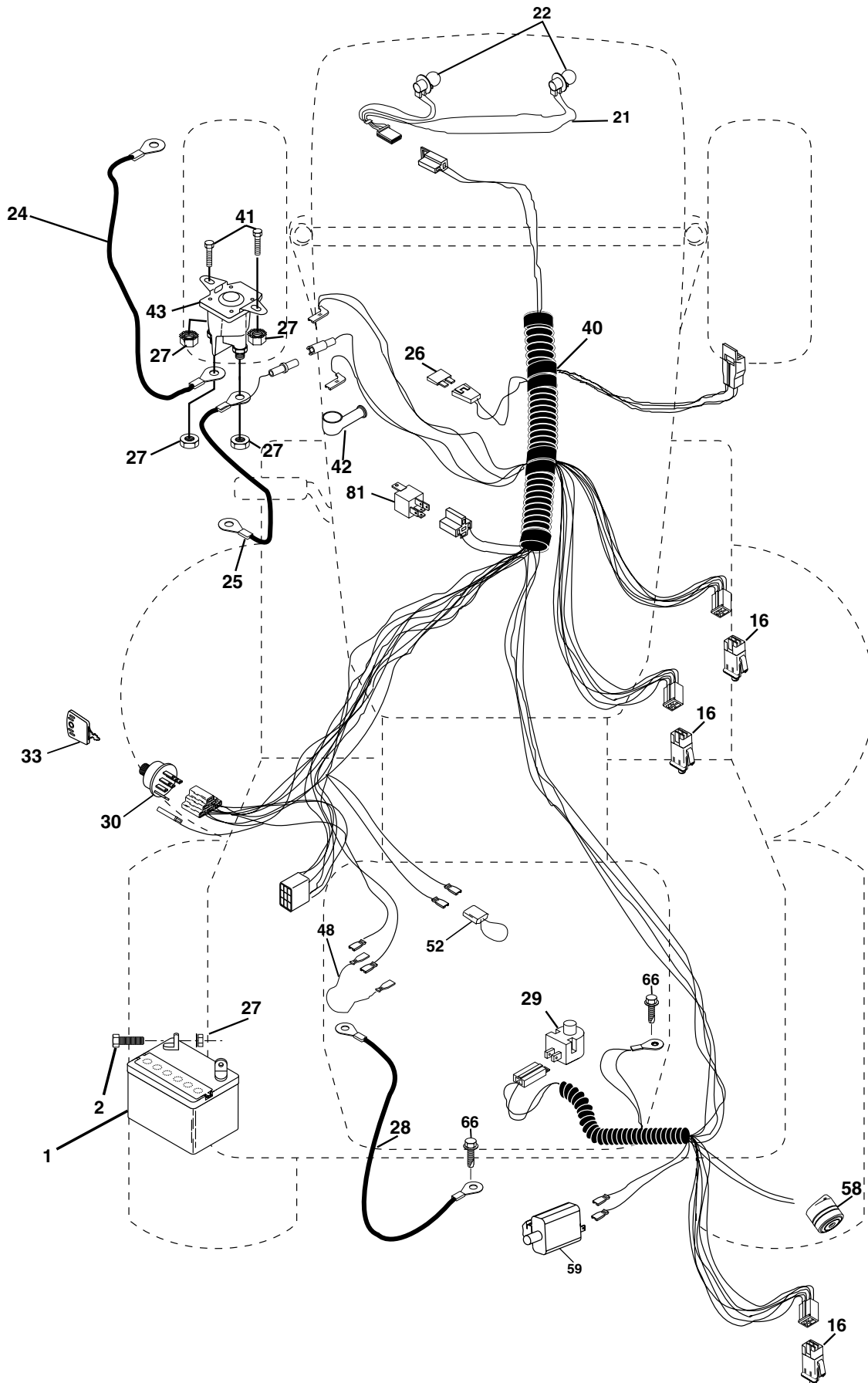

REPAIR PARTS

TRACTOR- -MODEL NO. MAC 15107-AP (MA15542RA), PRODUCT 964 77 43-00
ELECTRICAL

KEY NO.	PART NO.	DESCRIPTION
1	163465	Battery
2	74760412	Bolt Hex Hd 1/4-20 Unc X 3/4
16	176138	Switch Interlock
21	175685	Harness Asm Light W/4152J
22	4152J	Bulb Light #1156
24	4799J	Cable Battery
25	165987	Cable Battery Crd 56" Red
26	175158	Fuse
27	73510400	Nut Keps Hex 1/4-20 Unc
28	127725X	Cable Ground 6Ga 18" Black
29	160784	Switch Plunger Normal Op Olive
30	175566	Switch Ignition
33	140401	Key Ign Molded
40	179728	Harness Ign Crd Noram
41	71110408	Bolt Flk Fin Hex 1/4-20 Unc X 1/2
42	131563	Cover Terminal Red
43	178861	Solenoid
48	140844	Adapter Ammeter Rectangular
52	141940	Protection Wire Loop
58	169419	Buzzer Crd
59	180379	Switch FBI CRD
66	17490608	Screw Thdrol 3/8-16 x 1/2 Ty-Tt
81	109748X	Relay Asm

NOTE: All component dimensions given in U.S. inches.
1 inch = 25.4 mm.

REPAIR PARTS

TRACTOR- -MODEL NO. MAC 15107-AP (MA15542RA), PRODUCT 964 77 43-00 CHASSIS AND ENCLOSURES

KEY NO.	PART NO.	DESCRIPTION	KEY NO.	PART NO.	DESCRIPTION
1	174620	Chassis	58	150127	Duct Air Engine
2	180384	Drawbar	69	142432	Screw Hex Wsh
3	17060612	Screw 3/8-16 x 3/4	89	177288X428	Console
5	155272	Bumper Hood/Dash	145	156524	Rod Pivot Chassis/Hood
6	155923	Saddle	162	180382	Bracket Exten Chassis Lh CRD
8	126471X	Clip Insulator 13/32 Mtg. Hole	163	180383	Bracket Exten Chassis Rh CRD
9	168347X011	Dash	164	165605	Support Battery CRD
10	72140608	Bolt, Carriage 3/8-16 x 3/4	165	179020X428	Cover Battery
11	174996	Panel, Dash, L.H.	170	179053	Backplate Asm CRD
12	145660	Clip Tinnerman	171	72140620	Bolt Rdhd Sqnk 3/8-16 x 2-1/2 Gr. 5
13	172105X010	Panel, Asm. Dash R.H.	172	19132016	Washer 13/32 x 1-1/4 x 16 Ga.
15	74180512	Screw, Machine, Truss Head 5/16-18 UNC x 3/4	173	73510600	Nut, Keps Hex 3/8-16 UNC
16	73510500	Nut	175	180310	Door Trap
17	159639X622	Hood	179	180376	Rod Pivot FBI CRD
18	126938X	Bumper Hood	184	174662	Bracket Actuator Bagger CRD
20	180679	Plate Mtg Battery/Fuel	185	179608X505	Knob Rod Brake Parking
24	74780616	Bolt	186	160793	Latch Asm Mulch/Bagger
25	19131312	Washer 13/32 x 13/16 x 12 Gauge	187	2029J	Nut Weld
26	73800600	Nut	188	19061216	Washer #10
28	179845	Grille /Lens Asm	189	10071000	Washer Lock #10
29	170472X599	Lens, Grille	190	71081010	Screw Pan Hd Phillip 10-24 x 5/8
30	169962X622	Fender	198	168937	Nut, Push
31	165156	Bracket, Fender Support	205	17490608	Screw Thdrol 3/8-16 x 1/2
33	179716X622	Footrest, L.H.	208	17670608	Screw Thdrol 3/8-16 x 1/2
34	179717X622	Footrest, R.H.	209	17000612	Screw Hex Wsh Thdrol 3/8-16
35	72110606	Bolt	212	156229	Insert Lens Reflective
37	17490508	Screw Thdrol 5/16-18 x 1/2 TYT	214	4497H	Retainer Spring
38	181748	Bracket Asm Pivot Mower Rear	215	17060508	Screw 5/16-18 x 1/2
51	73800400	Nut Lock w/Fns 1/4-20	219	17000512	Screw 5/16-18 x 3/4
52	19091416	Washer 9/32 x 7/8 x 16 Ga.	256	180810X428	Cover Fender Rack CRD
53	144697	Bracket Grille LH	--	5479J	Plug, Button
54	161464	Screw Hex WSHD 8-18 x 7/8			
55	144696	Bracket Grille RH			
57	74780412	Bolt Fins Hex 1/4-20 x 3/4			

NOTE: All component dimensions given in U.S. inches.
1 inch = 25.4 mm.

REPAIR PARTS

TRACTOR- -MODEL NO. MAC 15107-AP (MA15542RA), PRODUCT 964 77 43-00
DRIVE

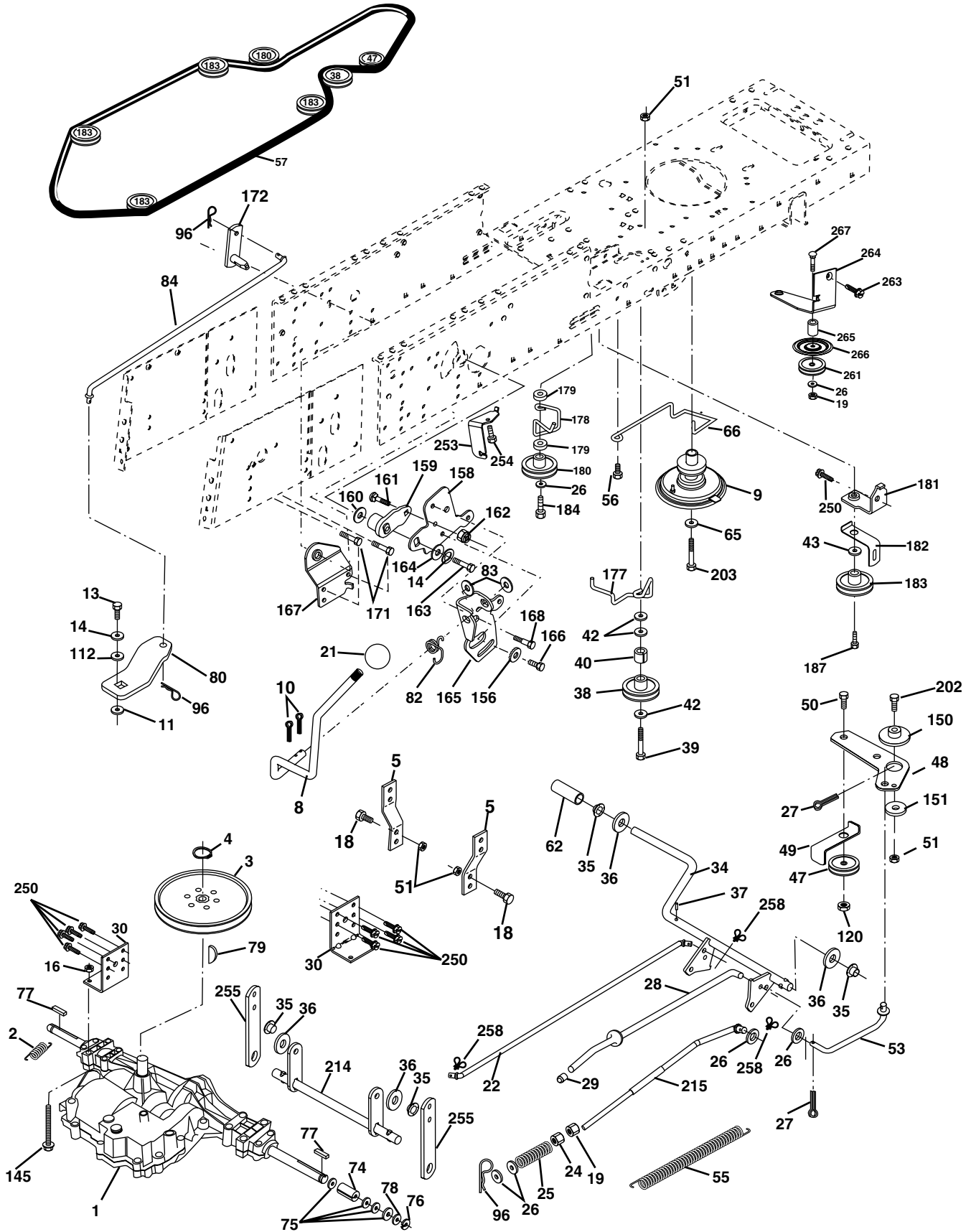

REPAIR PARTS

TRACTOR- -MODEL NO. MAC 15107-AP (MA15542RA), PRODUCT 964 77 43-00 DRIVE

KEY NO.	PART NO.	DESCRIPTION	KEY NO.	PART NO.	DESCRIPTION
1	-----	Transaxle Peerless 206-546 (Order parts from transaxle manufacturer)	80	145090	Arm Shift PMST 20" Tires
2	146682	Spring Brake Return	82	165711	Spring, Torsion
3	165999	Pulley Transaxle	83	19171216	Washer 17/32 x 3/4 x 16 Ga.
4	12000028	Ring Retainer #5100-62	84	165620	Link Shift CRD Pmst 18" Tires
5	121520X	Strap torque 30 degrees	96	4497H	Spring, Retainer 1"
8	165619	Rod Shift Fender Adjust Lt	112	19091210	Washer 9/32 x 3/4 x 10 Ga.
9	180354	Clutch Asm Noram	120	73900600	Nut Lock Flg. 3/8-16 UNC
10	76020416	Pin, Cotter 1/8 x 1	145	74490540	Bolt Hex FGHD 5/16-18 x Gr 5
11	105701X	Washer Plate Shf .3888 sq hole	150	165850	Bushing, Bellcrank Grnd Dr
13	74550412	Bolt 1/4-28 Unf Gr 8 w/patch	151	19133210	Washer 13/32 x 2 x 10 Ga.
14	10040400	Washer, Lock Hvy Helical	156	166002	Washer Srrd 5/16 ID x 1.125
16	73800500	Nut, Lock Hex w/Ins 5/16-18 UNC	158	165589	Bracket Shift Mount
18	74780616	Bolt Hex 3/8-16 UNC x 1 Gr.5	159	165494	Hub Tapered Flange Shift Lt
19	73800600	Nut, Lock Hex w/Wsh 3/8-16 UNC	160	19292016	Washer 29/32 x 1-1/4 x 16 Ga.
21	106933X	Knob Rd 1/2-13 Plstc Thds Blk	161	72140406	Bolt Rdhd Sqnk 1/4-20 x 3/4 Gr 5
22	175607	Rod, Brake CRD	162	73680400	Nut Crownlock 1/4-20 Unc
24	73350600	Nut	163	74780416	Bolt Hex Fin 1/4-20 Unc x 1 Gr 5
25	106888X	Spring, Rod, Brake	164	19091010	Washer 5/8 x .281 x 10 Ga.
26	19131316	Washer 13/32 x 13/16 x 16 Ga.	165	165623	Bracket Pivot Lever
27	76020412	Pin, Cotter 1/8 x 3/4	166	166880	Screw 5/16-18 x 5/8
28	175765	Rod, Parking Brake	167	165588	Bracket Support Shift CRD
29	71673	Cap, Parking Brake	168	165492	Bolt Shoulder 5/16-18 x .561
30	169592	Bracket, Mfg. Transaxle	171	17490608	Screw Thdrol 3/8-16 x 1/2 Ty-Tt
34	175578	Shaft, Asm Pedal Foot	172	165635	Shaft Asm Shift Front CRD PMST
35	120183X	Bearing, Nylon	177	165932	Keeper Flat Idler 3.06" CRD
36	19211616	Washer 21/32 x 1 x 16 Ga.	178	165933	Keeper Belt Idler 1.88" CRD
37	1572H	Pin, Roll 3/16 x 1"	179	120958X	Washer Sintered
38	165936	Pulley, Flat	180	165630	Pulley Flat Idler
39	74760644	Bolt Fin Hex 3/8-16 Unc x 2-3/4	181	180211	Bracket Idler Ground Drive CRD
40	4470J	Spacer, Split 395 x 59 Bzp	182	165634	Keeper Belt 2.5" Od V-Idler CRD
42	19131312	Washer 13/32 x 13/16 x 12 Ga.	183	179050	Pulley V-Idler
47	127783	Pulley, Idler, V Groove Plasitc	184	17490644	Screw Hexwsh Thdrol 3/8-16 x 2-3/4
48	154407	Bellcrank Clutch Grnd Drv	187	17580520	Screw thdrol 5/16-18 x 1 1/4
49	123205X	Retainer, Belt Style Spring	202	72110614	Bolt 3/8-16 x 1 3/4 Gr. 5
50	74760624	Bolt Hex Hd 3/8-16 UNC x 1-1/2	203	71170780	Bolt Hex 7/16-20 x 5
51	73680600	Nut, Crownlock 3/8-16 UNC	214	175609	Shaft Asm Blade
53	105710X	Link, Clutch 7.66	215	175651	Rod Brake Secondary
55	105709X	Spring, Return, Clutch	250	17060612	Screw 3/8-16 x .75
56	17060620	Screw 3/8-16 x 1-1/4	253	175028	Bracket Cable Chassis
57	165631	V-Belt Kev PMST CRD	254	17060616	Screw 3/8-16 x 1
62	8883R	Cover, Pedal	255	175608	Brace Shaft Brake Mtg.
65	10040700	Washer	258	178062	Clip Retainer
66	154778	Keeper, Belt Engine F-Proof	261	173438	Pulley Idler Flt
74	137057	Spacer Axle	263	17000612	Screw Hex Wsh Thdr 3/8-16 x 3/4
75	121749X	Washer 25/32 x 1-1/4 x 16 Ga.	264	181995	Bracket Clutch Mounting
76	12000001	Ring, E	265	182013	Spacer Idler Chassis
77	123583X	Key, Square	266	182061	Shield Idler Mower
78	121748X	Washer 25/32 x 1-5/8 x 16 Ga.	267	72140624	Bolt RDHD 3/8-16unc x 3
79	2228M	Key Woodruff			

NOTE: All component dimensions given in U.S. inches
1 inch = 25.4 mm

REPAIR PARTS

TRACTOR- -MODEL NO. MAC 15107-AP (MA15542RA), PRODUCT 964 77 43-00
STEERING ASSEMBLY

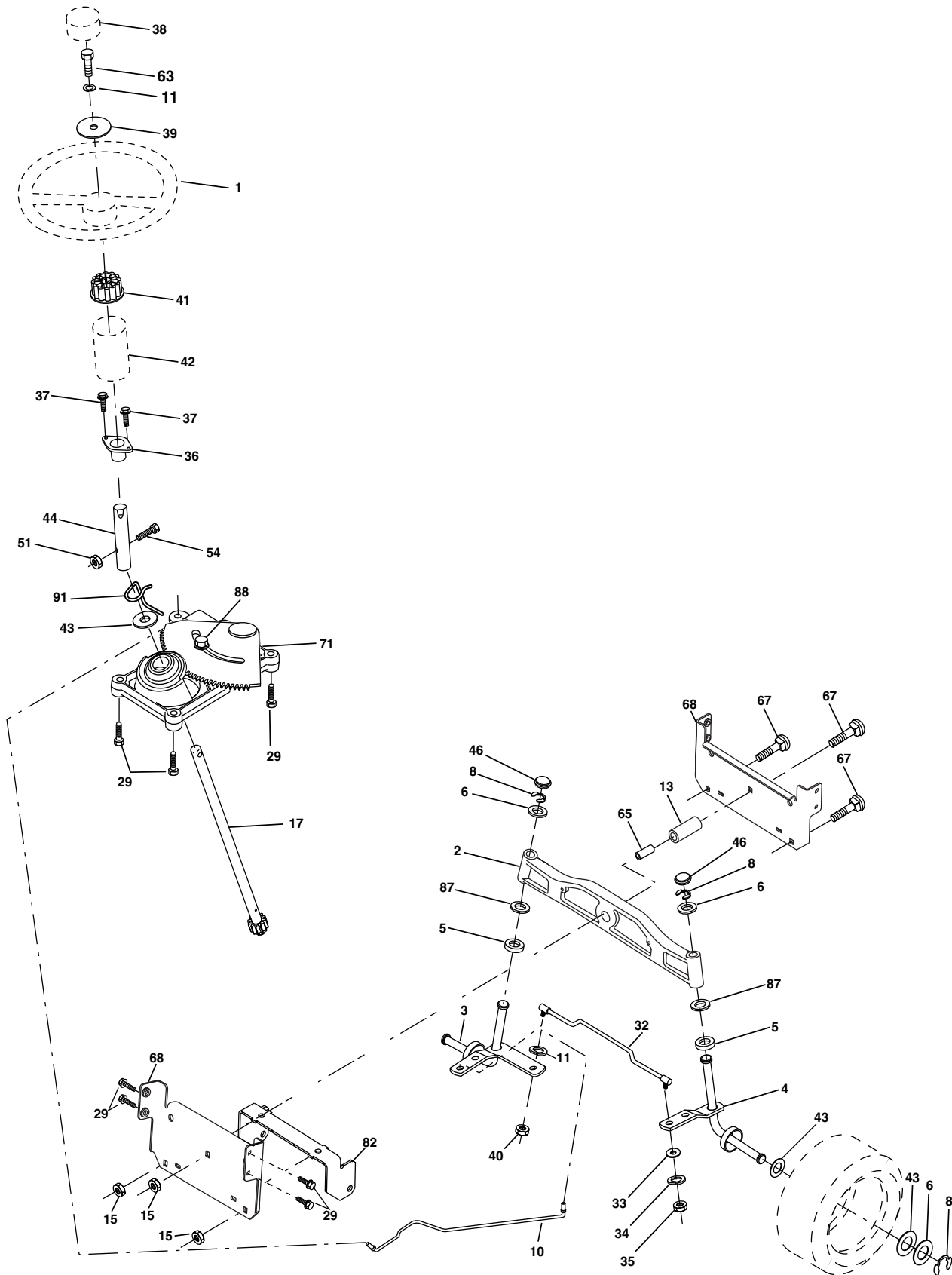

REPAIR PARTS

TRACTOR- -MODEL NO. MAC 15107-AP (MA15542RA), PRODUCT 964 77 43-00 STEERING ASSEMBLY

KEY NO.	PART NO.	DESCRIPTION
1	140044X428	Steering Wheel
2	172393	Axle Asm Cast Iron Lt
3	169840	Spindle Assembly, L.H.
4	169839	Spindle Assembly, R.H.
5	6266H	Washer, Thrust .75 x 1.230
6	121748X	Washer 25/32 x 1-5/8 x 16 Gauge
8	12000029	Ring, Klip
10	175121	Link, Drag
11	10040600	Washer, Lock
13	136518	Spacer Brg Axle Front
15	145212	Nut, Hex Flange Lock
17	177876	Shaft Assembly, Steering
29	17060612	Screw 3/8-16 x 3/4
32	170162	Rod, Tie
33	19111216	Washer 11/32 x 3/4 x 16 Ga.
34	10040500	Washer Lock Hvy Hlcl Spr 5/16
35	73540500	Crownlock Nut 5/16-24 Unf
36	155099	Bushing, Steering
37	152927	Screw TT #10-32 x 5 x 3/8 Flange
38	140045X428	Cap Wheel Steering
39	19133812	Washer 13/32 x 2-3/8 x 12 G
40	7810H	Nut Lock Center 3/8-24 Unf
41	100711L	Adaptor, Steering Wheel
42	145054X428	Boot, Steering Dash P/L Mtl
43	121749X	Washer 25/32 x 1-1/4 x 16 Gauge
44	153720	Extension Steering
46	121232X	Cap, Spindle
51	73800500	Nut Lock Hex w/Ins 5/16-18 UNC
54	74780520	Bolt Fin Hex 5/16-18 UNC x 1-1/4
63	74780616	Bolt Fin Hex 3/8-16 UNC x 1. Gr 5
65	160367	Spacer Brace Axle
67	72140618	Bolt Rdhd Sq 3/8-16 x 2-1/4
68	169827	Brace Axle
71	175146	Steering Asm.
82	169835	Bracket Susp Chassis Front 15"
87	173966	Washer Flat .781 x 1-1/2 x .14
88	175118	Bolt Shoulder 7/16-20 UNC
91	175553	Clip Steering

NOTE: All component dimensions given in U.S. inches.
1 inch = 25.4 mm.

REPAIR PARTS

TRACTOR- -MODEL NO. MAC 15107-AP (MA15542RA), PRODUCT 964 77 43-00
SEAT ASSEMBLY

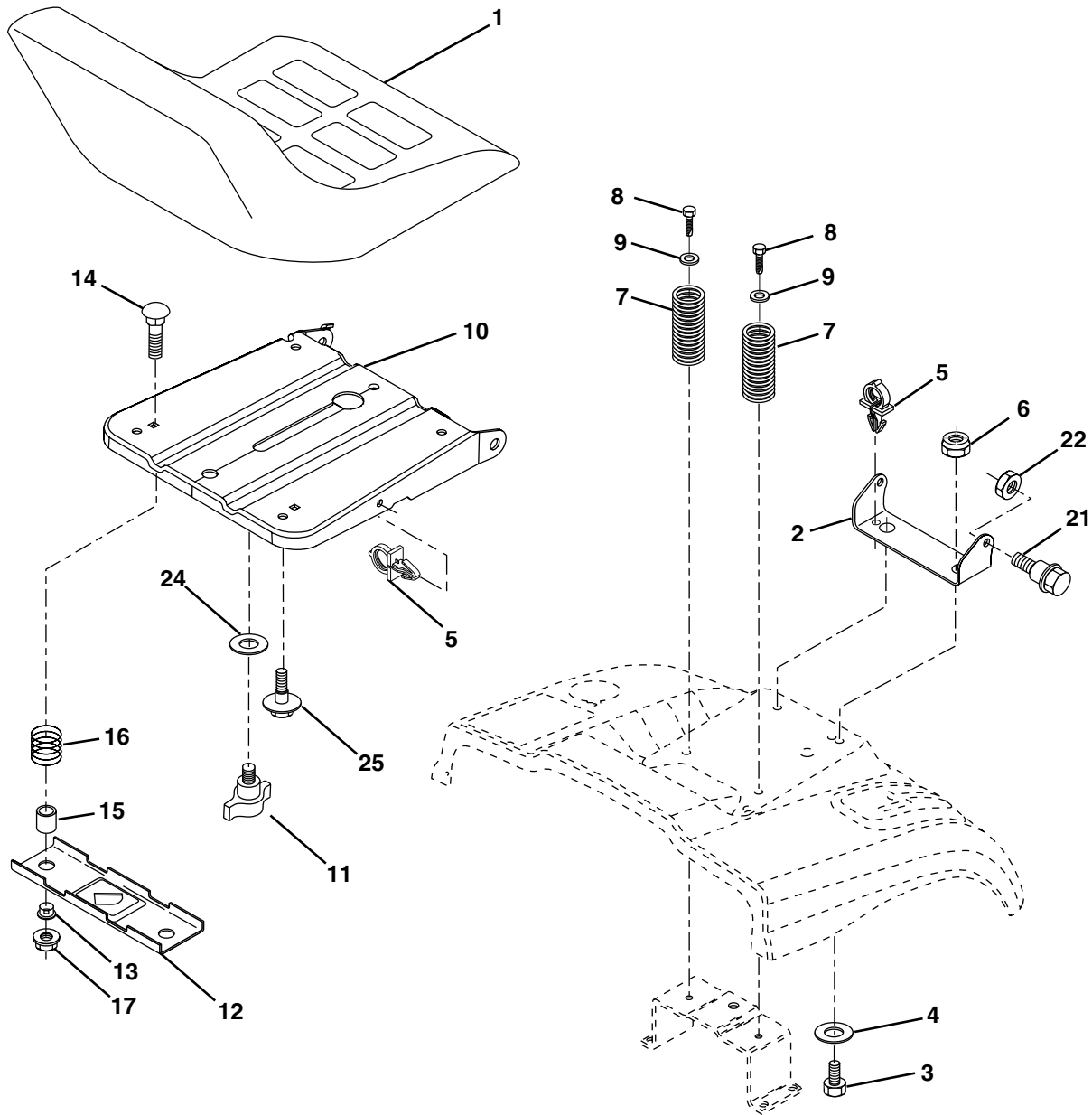

KEY NO.	PART NO.	DESCRIPTION
1	127427	Seat
2	140551	Bracket Pnt Pivot Seat (blk)
3	71110616	Bolt Fin Hex 3/8-16 UNC x 1
4	19131610	Washer Flat 13/32 x 1 x 10 Ga
5	145006	Clip Push In Hinged
6	73800600	Nut Lock Hex w/Ins 3/8-16 UNC
7	124181X	Spring Seat Cprsn 2 250 Blk Zi
8	17000616	Screw 3/8-16 X 1-1/2
9	19131614	Washer 13/32 X 1 X 14 Ga
10	174894	Pan Assembly Seat Tool-Free
11	166369	Knob Seat Adj. Wingnut
12	121246X	Bracket Pnt Mounting Switch

KEY NO.	PART NO.	DESCRIPTION
13	121248X	Bushing Snap Blk Nyl 50 Id
14	72050412	Bolt Rdhd Sht Nk 1/4-20x1-1/2
15	134300	Spacer Split
16	121250X	Spring Cprsn 1.27 Blk
17	123976X	Nut Lock 1/4 Lge Flg Gr 5 Zinc
21	171852	Bolt Shoulder 5/16-18 Unc-2A
22	73800500	Nut Hex Lock w/Ins 5/16-18
24	19171912	Washer 17/32 X 1-3/16 X 12 Ga.
25	127018X	Bolt Shoulder 5/16-18 X 62

NOTE: All component dimensions given in U.S. inches.
1 inch = 25.4 mm

REPAIR PARTS

TRACTOR- -MODEL NO. MAC 15107-AP (MA15542RA), PRODUCT 964 77 43-00
DECALS

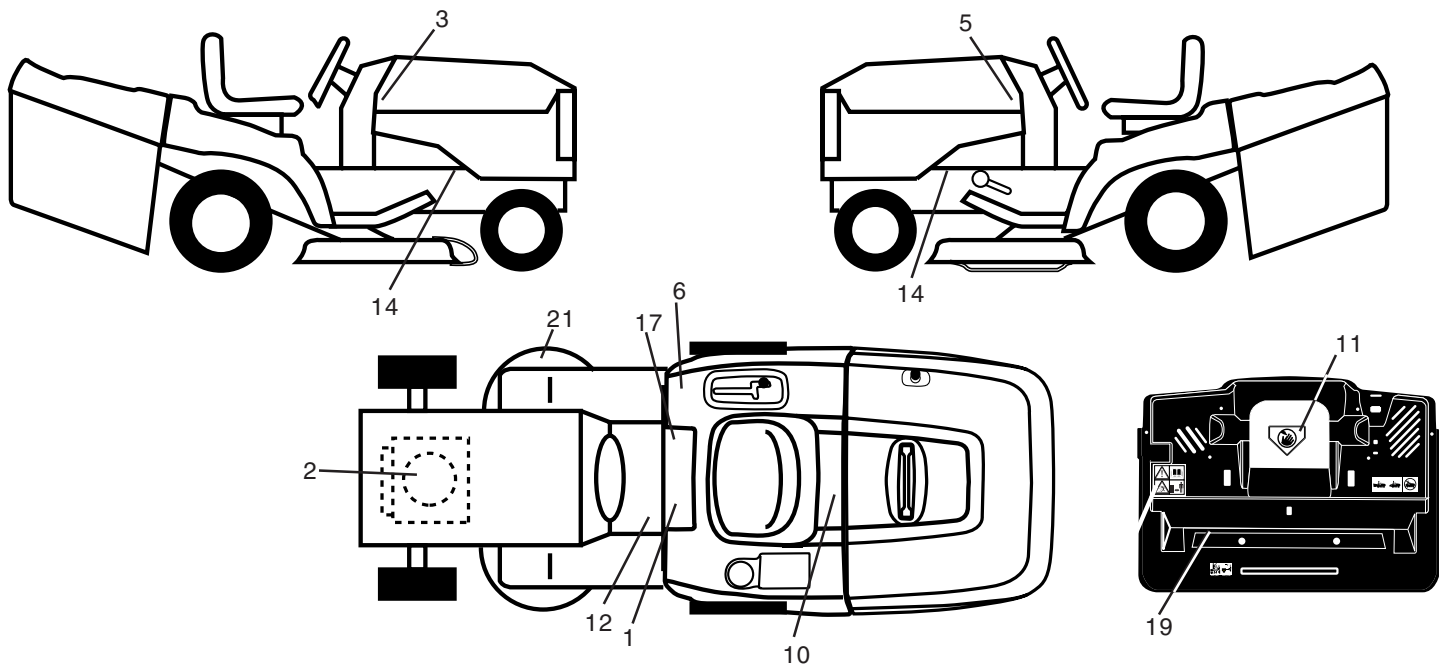

KEY NO.	PART NO.	DESCRIPTION
1	145498	Decal Read Owner's Manual Sym
2	176398	Decal Hp Engine
3	181828	Decal Hood RH
5	181829	Decal Hood LH
6	180432	Decal 100 DBA
10	145005	Decal Bat Dan/Poi P/L Sym Wpn
11	145494	Decal Mower Cut Finger Symbol
12	159737	Decal Brake/Clutch Symbol Lt
14	159736	Decal Chassis Hot Muffler

KEY NO.	PART NO.	DESCRIPTION
17	140837	Decal Saddle Brake Parking
19	180435	Decal Backplate CRD Symbols
21	166286	Decal Deck Sch
—	138311	Decal Lift Handle
—	179769X428	Pad Footrest R.H.
—	179768X428	Pad Footrest L.H.
—	181898	Manual Operator's (Euro)
—	181899	Manual Operator's (Scan)

WHEELS & TIRES

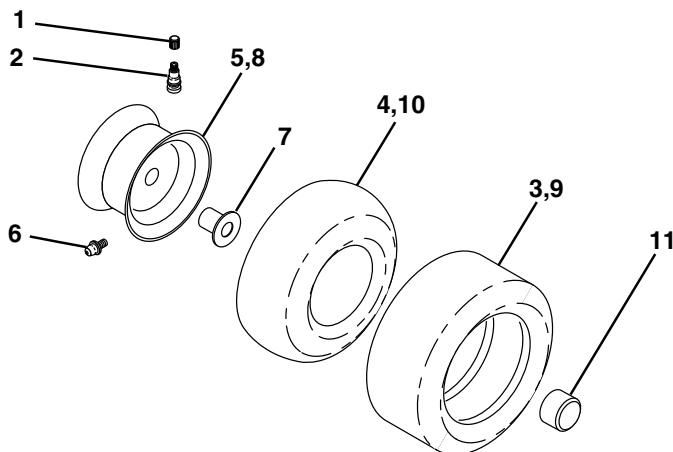

KEY NO.	PART NO.	DESCRIPTION
1	59192	Cap Value Tire
2	65139	Stem Value
3	106222X	Tire F Ts 15 X 6 0 - 6 Service
4	59904	Tube InnerFront #35060
5	106732X418	Rim Asm 6"front Service
6	278H	Fitting Grease
7	9040H	Bearing Flange
8	106108X418	Rim Asm 8"rear Service
9	138468	Tire R Ts 20 x 8-8 Service
10	7152J	Tube Rear 9 5 X 8 Service
11	104757X428	Cap Axle Blk 1 50 X 1 00
--	144334	Sealant, Tire (10 oz. tube)

NOTE: All component dimensions given in U.S. inches
1 inch = 25.4 mm

REPAIR PARTS

TRACTOR- -MODEL NO. MAC 15107-AP (MA15542RA), PRODUCT 964 77 43-00
ENGINE

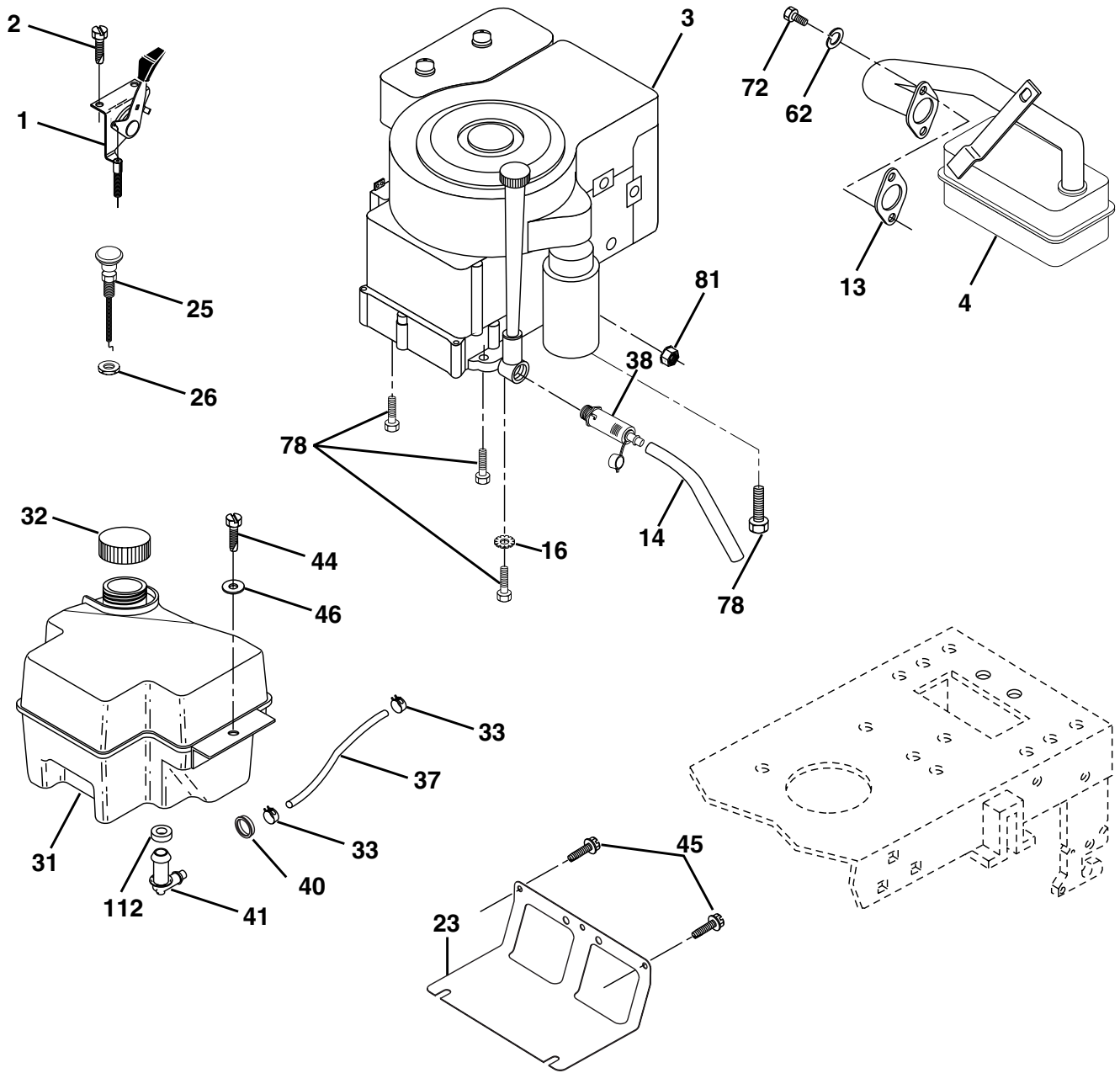

OPTIONAL EQUIPMENT
Spark Arrester

REPAIR PARTS

TRACTOR- -MODEL NO. MAC 15107-AP (MA15542RA), PRODUCT 964 77 43-00
ENGINE

KEY NO.	PART NO.	DESCRIPTION
1	170551	Control Throt/Ch
2	17720408	Screw Hex Thd Cut 1/4-20 x 1/2
3	-----	Engine Briggs Model 287707 (Order Parts from Engine Manufacturer)
4	137352	Muffler
13	165291	Gasket 1 313 Id Tin Plated
14	148456	Tube Drain Oil Easy
16	11050600	Washer Lock Ext Tooth 3/8
23	169837	Shield Browning/Debris Guard
25	180945	Control Choke
26	73920600	Nut Keps 3/8-24 Unf
29	137180	Arrestor Spark
31	180645	Tank Fuel
32	140527	Cap Asm Fule Top Vent N/Lany
33	123487X	Clamp Hose Blk
37	137040	Line Fuel 20"
38	148315	Oil Drain Plug Easy
40	124028X	Bushing Snap
41	139277	Stem Tank Fuel
44	17670412	Screw Hexwsh Thdrol 1/4-20x3/4
45	17000612	Screw Hexwsh Thdrol 3/8-16 x 3/4
46	19091416	Washer 9/32 X 7/8 X 16ga
62	10040500	Washer Lock Hvy Hlcl Spr 5/16
72	71070512	Screw Hex Hd Cap 5/16-18 x 3/4
78	17060620	Screw 3/8-16x1-1/4
81	73510400	Nut Keps Hex 1/4-20 Unc
112	3645J	Bushing

NOTE: All component dimensions given in U.S. inches
1 inch = 25.4 mm

REPAIR PARTS

TRACTOR- -MODEL NO. MAC 15107-AP (MA15542RA), PRODUCT 964 77 43-00
MOWER LIFT

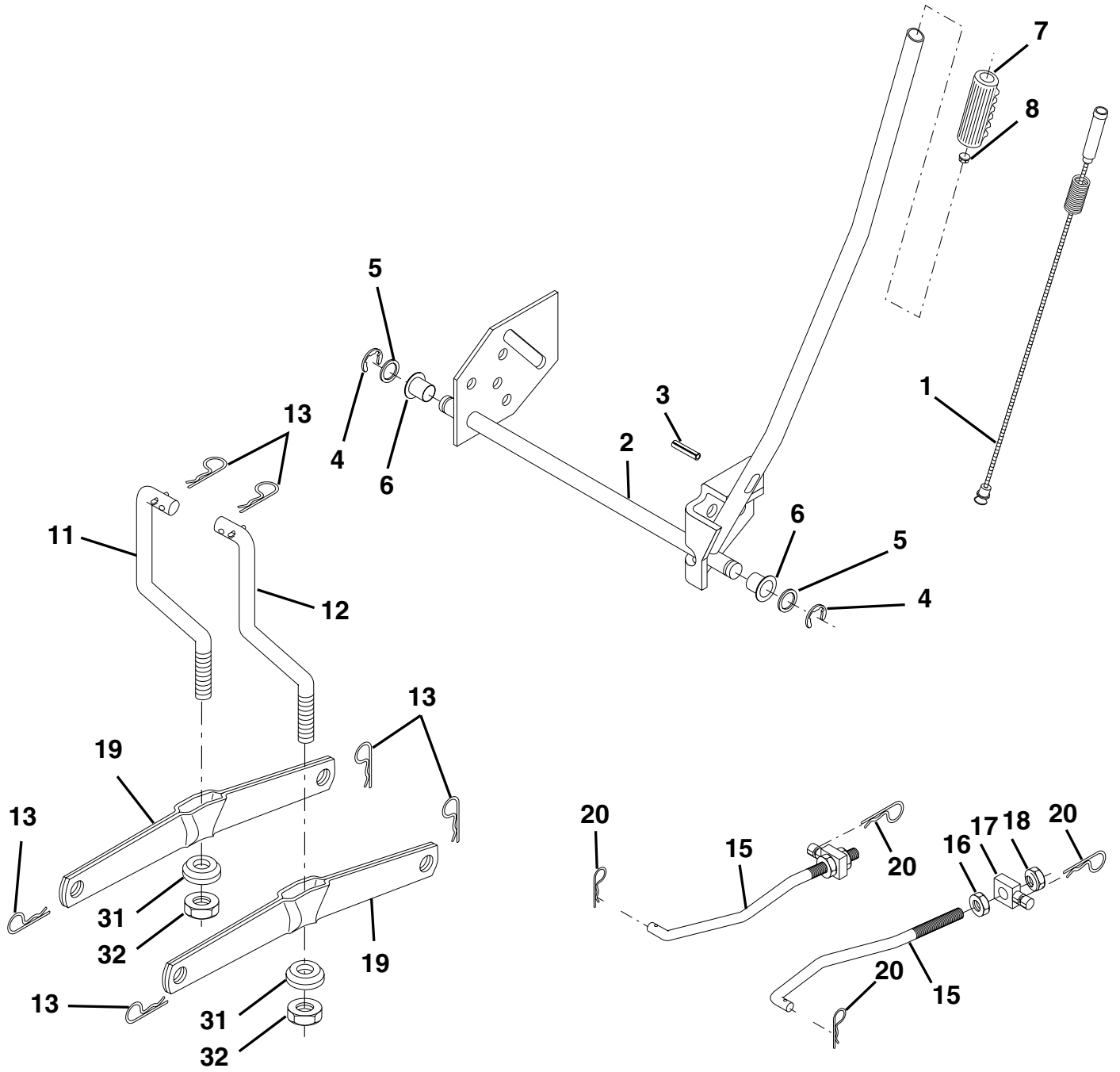

REPAIR PARTS

TRACTOR- -MODEL NO. MAC 15107-AP (MA15542RA), PRODUCT 964 77 43-00
MOWER LIFT

KEY NO.	PART NO.	DESCRIPTION
1	159460	Washer Asm Inner Spring W/Plunger
2	159471	Shaft Asm. Lift
3	105767X	Pin Groove
4	12000002	E Ring #5133-62
5	19211621	Washer 21/32 x 1 x 21 Ga.
6	120183X	Bearing Nylon
7	109413X	Grip Handle
8	124526X	Button Plunger Black
11	165829	Link Asm Lift L.H.
12	165831	Link Asm Lift R.H.
13	4939M	Retainer Spring
15	173288	Link Front
16	73350800	Nut Jam Hex 1/2-13 Unc
17	175689	Trunnion
18	73800800	Nut Lock w/Wsh 1/2-13 Unc
19	139868	Arm Suspension Mower
20	163552	Retainer Spring
31	169865	Bearing, Pvt. Lift.
32	73540600	Nut Crownlock 3/8-24

NOTE: All component dimensions given in U.S. inches
1 inch = 25.4 mm

REPAIR PARTS

TRACTOR- -MODEL NO. MAC 15107-AP (MA15542RA), PRODUCT 964 77 43-00
MOWER

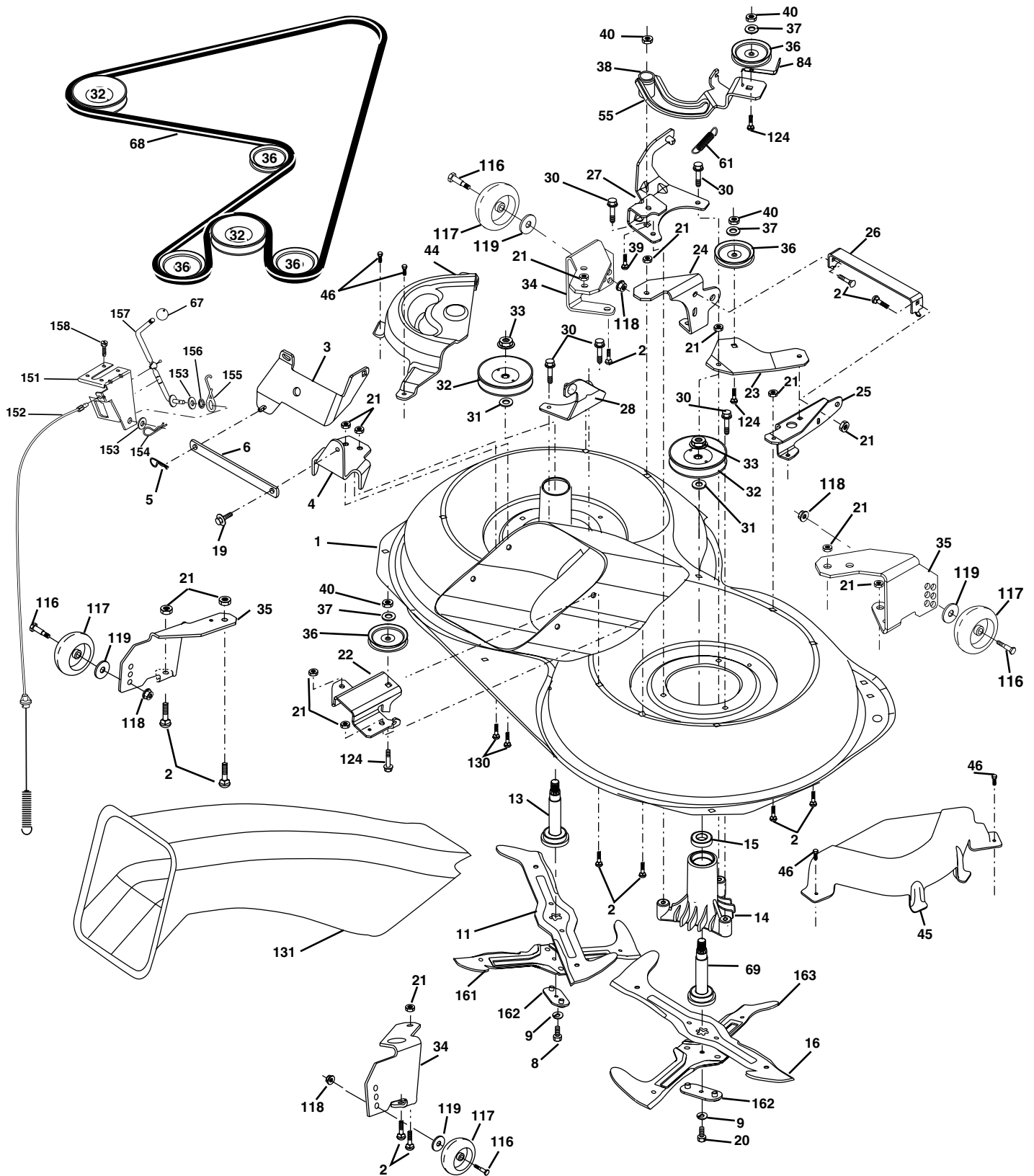

REPAIR PARTS

**TRACTOR- -MODEL NO. MAC 15107-AP (MA15542RA), PRODUCT 964 77 43-00
MOWER**

KEY NO.	PART NO.	DESCRIPTION	KEY NO.	PART NO.	DESCRIPTION
1	169160	Housing Asm. Mower	44	175538	Cover Mandrel Lh
2	72140506	Bolt Rdhd Sqnk 5/16-18 Unc x 3/4	45	175539	Cover Mandrel Rh
3	165569	Bracket Asm. S-Bar Chass	46	137729	Screw Thd Roll 1/4-20 x 5/8
4	169167	Bracket Bar Sway Deck	55	169849	Arm Idler 107 CRD
5	4939M	Retainer Spring	61	175159	Spring Tension Belt
6	165557	Bar Sway	67	106932X	Knob Rd 3/8-16 Plstc Thds Blk
8	181712	Bolt 3/8-24 x 1.25 Gr8 Patched	68	169178	Hex-Belt Mower
9	10030600	Washer Lock Hvy 3/8 Unplated	69	165482	Shaft Asm W/Lwr Brg Rh Thd CRD
11	180583	Blade 3-1 Lh	84	156085	Keeper Belt Idler
13	137645	Shaft Asm. W/Lower Bearing	116	137644	Bolt Shoulder
14	128774	Housing Mandrel Vented (Machd)	117	133957	Wheel Gage Donut Wide
15	110485X	Bearing Ball Mandrel	118	73930600	Nut Centerlock 3/8-16 Unc
16	180583	Blade 3-1 Rh	119	19121414	Washer 3/8 x 7/8 x 14 Ga.
19	132827	Bolt Shoulder 5/16-18 Thd Form	124	72110612	Bolt Carr Sh 3/8-16 x 1-1/2 Gr5
20	181713	Bolt 3/8-24 x 1.25 Gr8 Ptch Lhthd	130	72110506	Bolt Rdhdsqnk 5/16-18 Unc x 3/4
21	73680500	Nut Crown Lock 5/16-18	131	165661	Chute Bagger CRD
22	169165	Bracket Idler RR	151	169670	Bracket Clutch Cable
23	169166	Bracket Idler RF	152	176074	Cable Clutch CRD Service
24	169170	Bracket Suspension LF	153	169674	Washer Flat 3/8" Type B
25	169171	Bracket Suspension RF	154	169675	Spring Retainer
26	165237	Brace Support Susp Frt CRD	155	169671	Spring Retention Lvr Cltch Cab
27	169172	Bracket Asm. Susp RR	156	169672	Spacer Clutch Cable
28	169168	Bracket Asm. Susp LR	157	169669	Rod Clutch Cable 3/8"
30	173984	Screw Thd Rolling Dod Pt	158	17720408	Screw Hex Thd Cut 1/4-20 x 1/2
31	129963	Washer Spacer Mower Vented	161	180424	Blade Cross LH
32	175707	Mandrel Pulleys	162	180878	Adapter Weldment Blade
33	178342	Nut Flg Top Lock	163	180425	Blade Cross RH
34	179509	Bracket Gauge Wheel Lf	-	181857	Mandrel Assembly (Includes Housing, Shaft and Shaft Hardware Only - Pulley Not Included)
35	176292	Bracket Gauge Wheel Rf	-	181858	Mandrel Asm CRD Lh Threads SVC
36	146763	Pulley Idler V-Groove Dim 4.25	-	181770	Replacement Mower Complete
37	19131316	Washer 11/32 x 13/16 x 16 Ga			
38	169851	Spacer Hub Arm Idler 107 CRD			
39	72110622	Bolt Crownlock 3/8-16 Unc			
40	73680600	Nut Crownlock 3/8-16 Unc			

NOTE: All component dimensions given in U.S. inches
1 inch = 25.4 mm

REPAIR PARTS

TRACTOR- -MODEL NO. MAC 15107-AP (MA15542RA), PRODUCT 964 77 43-00
BAGGER

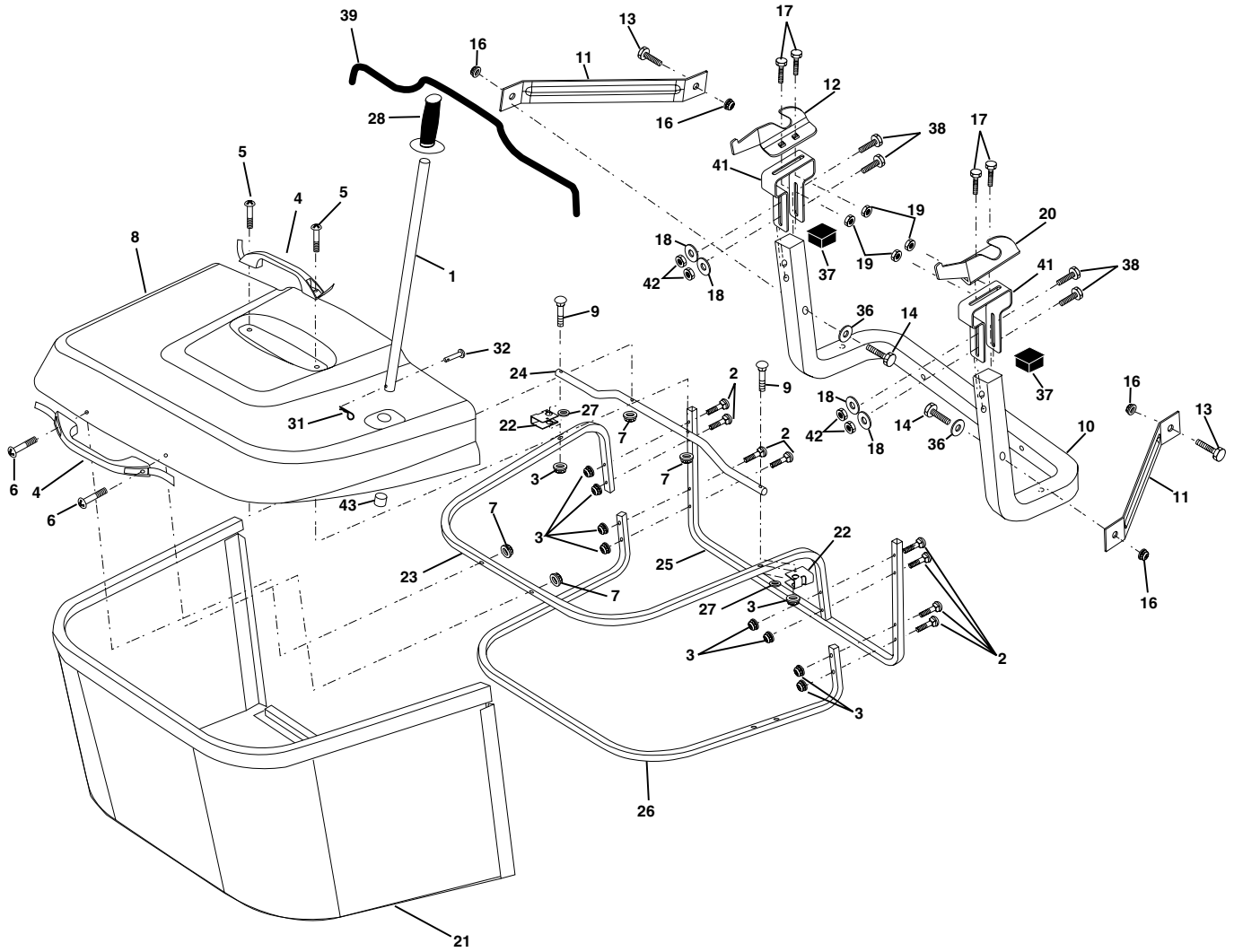

REPAIR PARTS

TRACTOR- -MODEL NO. MAC 15107-AP (MA15542RA), PRODUCT 964 77 43-00
BAGGER

KEY NO.	PART NO.	DESCRIPTION
1	165249	Tube Handle Bagger CRD
2	72140416	Bolt Carriage 1/4-20 x 2.0 Gr.5
3	123976X	Nut Lock 1/4 Lge Flg Gr. 5 Zinc
4	169916	Handle Bagger w/Lvrs Blk CRD
5	74981024	Screw Pan Head #10-24 x 1.50 Blk
6	74981032	Screw Pan Hd
7	73401000	Nut Wiz Lock Hex Serr/Hd 10-24
8	169963X622	Cover Bagger
9	72140418	Bolt Carriage 1/4-20 x 2.25d x Gr.5
10	181282	Tube Support Bagger CRD
11	165719	Bracket Support Upper Bag CRD
12	169685	Bracket Horizon Adj Bggr Lh CRD
13	72110606	Bolt Rdhd Sht Sqnk 3/8-16 x 3/4
14	74520636	Bolt Hex Fin 3/8-16 x 2-1/4 Gr.5
16	73900600	Nut Lock Flg 3/8-16 Unc
17	72140506	Bolt Rdhd Sht Sqnk 5/16 -18 Unc x 3/4
18	19111216	Washer 1 1/32 x 3/4 x 16 Ga.
19	73900500	Nut Lock Hex Flange 5/16-18
20	169684	Bracket Horiz Adj Bggr RH CRD
21	180880	Bag Asm CRD
22	165781	Bracket Side Bagger CRD
23	165782	Tube Upper Bagger CRD
24	165783	Tube Pivot Bagger CRD
25	180124	Tube Front Bagger CRD
26	165785	Tube Lower Bagger CRD
27	169692	Bufshing Snap Bagger CRD
28	165787	Grip Handle Black
31	4497H	Retainer Spring 1" Zinc/Cad
32	126875X	Rivet Rd Hd Drilled 3/8 Dia
36	19132016	Washer 13/32 x 1-1/4 x 16 Ga.
37	175401	Plug Suport Bagger CRD
38	72010520	Bolt 5/16-18 x 2-1/2
39	180985	Seal 37"
41	169683	Bracket Vert Adj Bagger CRD
42	73800500	Nut Lock Hex W/Ins 5/16-18 Unc PI

NOTE: All component dimensions given in U.S. inches
1 inch = 25.4 mm

TRACTOR- -MODEL NO. MAC 15107-AP (MA15542RA), PRODUCT 964 77 43-00 SCHEMATIC

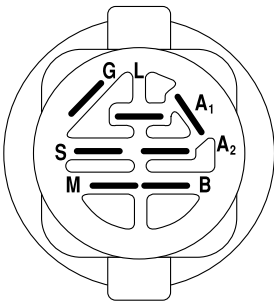
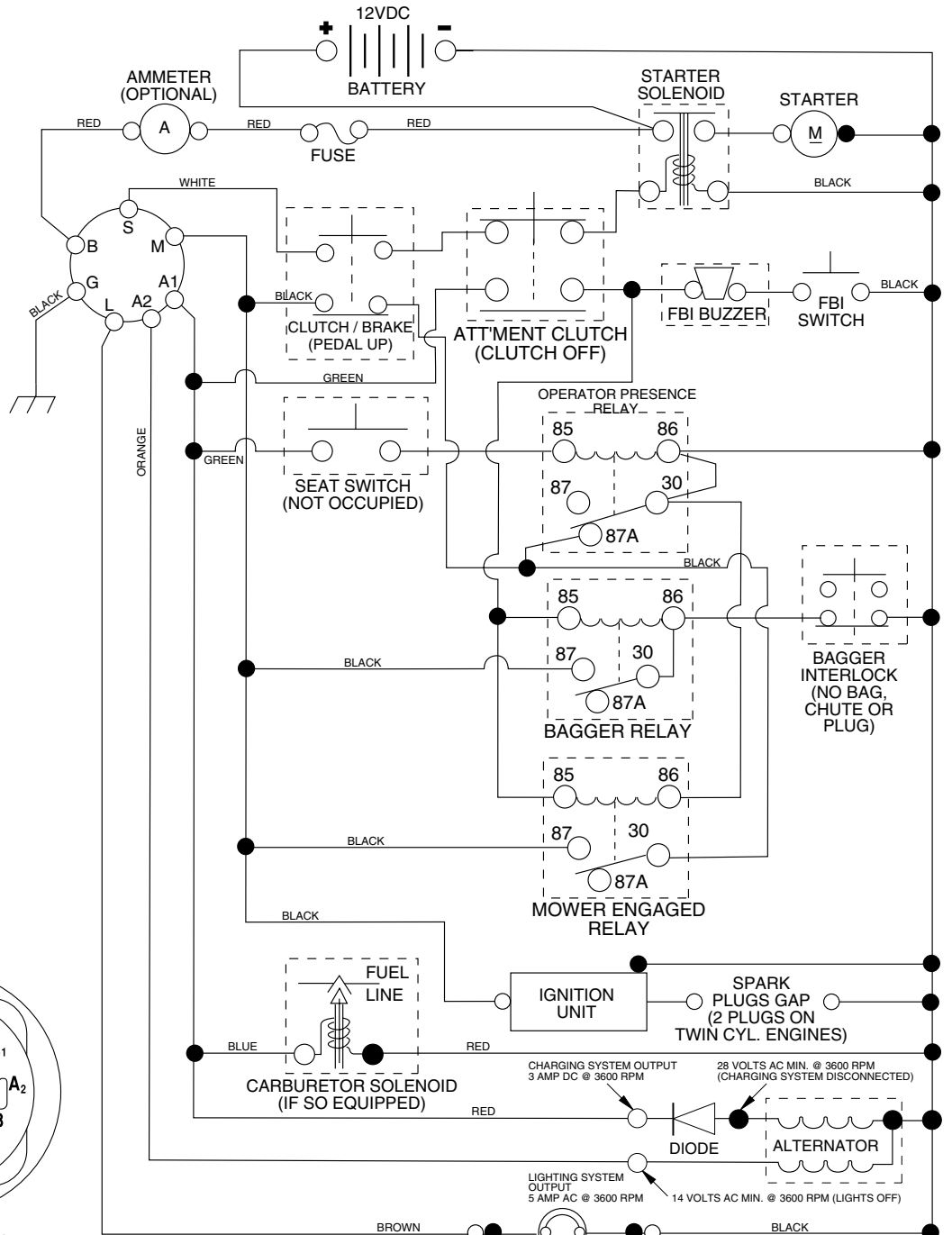

IGNITION SWITCH

POSITION	CIRCUIT	"MAKE"
OFF	M+G+A1	NONE
RUN/LIGHT	B+A1	A2+L
RUN	B+A1	NONE
START	B + S + A1	NONE

WIRING INSULATED CLIPS
NOTE: IF WIRING INSULATED CLIPS WERE REMOVED FOR SERVICING OF UNIT, THEY SHOULD BE REPLACED TO PROPERLY SECURE YOUR WIRING.



PTO SWITCH

POSITION	CIRCUIT
OFF	C + G, B + H
ON	C + F, B + E, A + D

HEADLIGHTS

NOTE
YOUR TRACTOR IS EQUIPPED WITH A SPECIAL ALTERNATOR SYSTEM. THE LIGHTS ARE NOT CONNECTED TO THE BATTERY, BUT HAVE THEIR OWN ELECTRICAL SOURCE. BECAUSE OF THIS, THE BRIGHTNESS OF THE LIGHTS WILL CHANGE WITH ENGINE SPEED. AT IDLE THE LIGHTS WILL DIM. AS THE ENGINE IS SPEEDED UP, THE LIGHTS WILL BECOME THEIR BRIGHTEST.

