

ILLUSTRATED PARTS BREAKDOWN

MAC ALLISTER

15.5 HP 107 LAWN TRACTOR

MODEL NO. MAC 15107-AP (MA15542RB)

964 77 43-00

REPAIR PARTS

TRACTOR- -MODEL NO. MAC 15107-AP (MA15542RB), PRODUCT 964 77 43-00
ELECTRICAL

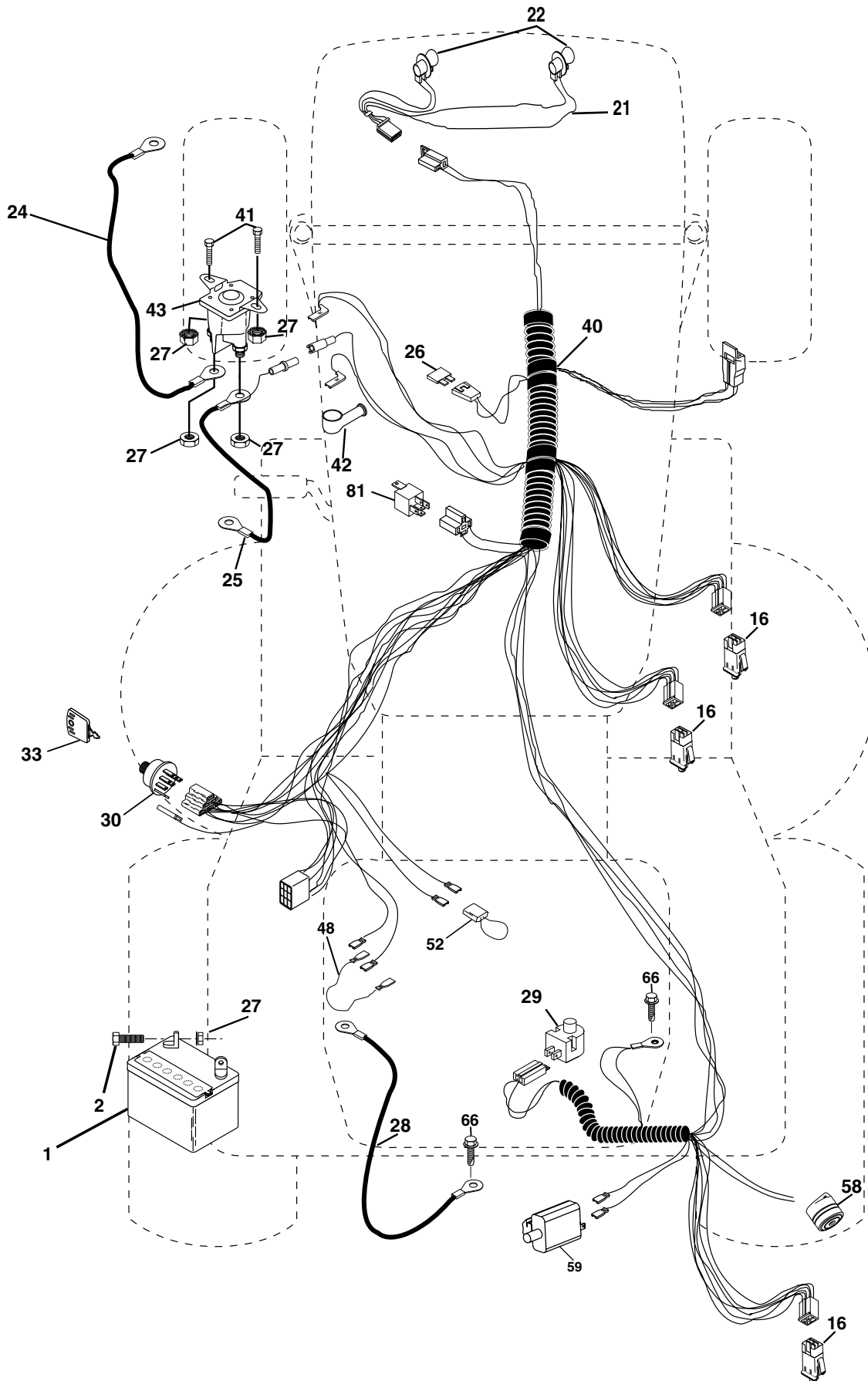

REPAIR PARTS

TRACTOR- -MODEL NO. MAC 15107-AP (MA15542RB), PRODUCT 964 77 43-00
ELECTRICAL

KEY NO.	PART NO.	DESCRIPTION
1	532 16 34-65	Battery
2	874 76 04-12	Bolt Hex Hd 1/4-20 Unc X 3/4
16	532 17 61-38	Switch Interlock
21	532 17 56-85	Harness Asm Light W/4152J
22	532 00 04-15	Bulb Light #1156
24	532 12 47-80	Cable Battery
25	532 16 59-87	Cable Battery Crd 56" Red
26	532 17 51-58	Fuse
27	873 51 04-00	Nut Keps Hex 1/4-20 Unc
28	532 12 77-25	Cable Ground 6Ga 18" Black
29	532 16 07-84	Switch Plunger Normal Op Olive
30	532 17 55-66	Switch Ignition
33	532 14 04-01	Key Ign Molded
40	532 17 97-28	Harness Ign Crd Noram
41	871 11 04-08	Bolt Flk Fin Hex 1/4-20 Unc X 1/2
42	532 13 15-63	Cover Terminal Red
43	532 17 88-61	Solenoid
48	532 14 08-44	Adapter Ammeter Rectangular
52	532 14 19-40	Protection Wire Loop
58	532 16 94-19	Buzzer Crd
59	532 18 03-79	Switch FBI CRD
66	817 49 06-08	Screw Thdrol 3/8-16 x 1/2 Ty-Tt
81	532 10 97-48	Relay Asm

NOTE: All component dimensions given in U.S. inches.
1 inch = 25.4 mm.

REPAIR PARTS

TRACTOR- -MODEL NO. MAC 15107-AP (MA15542RB), PRODUCT 964 77 43-00
CHASSIS AND ENCLOSURES

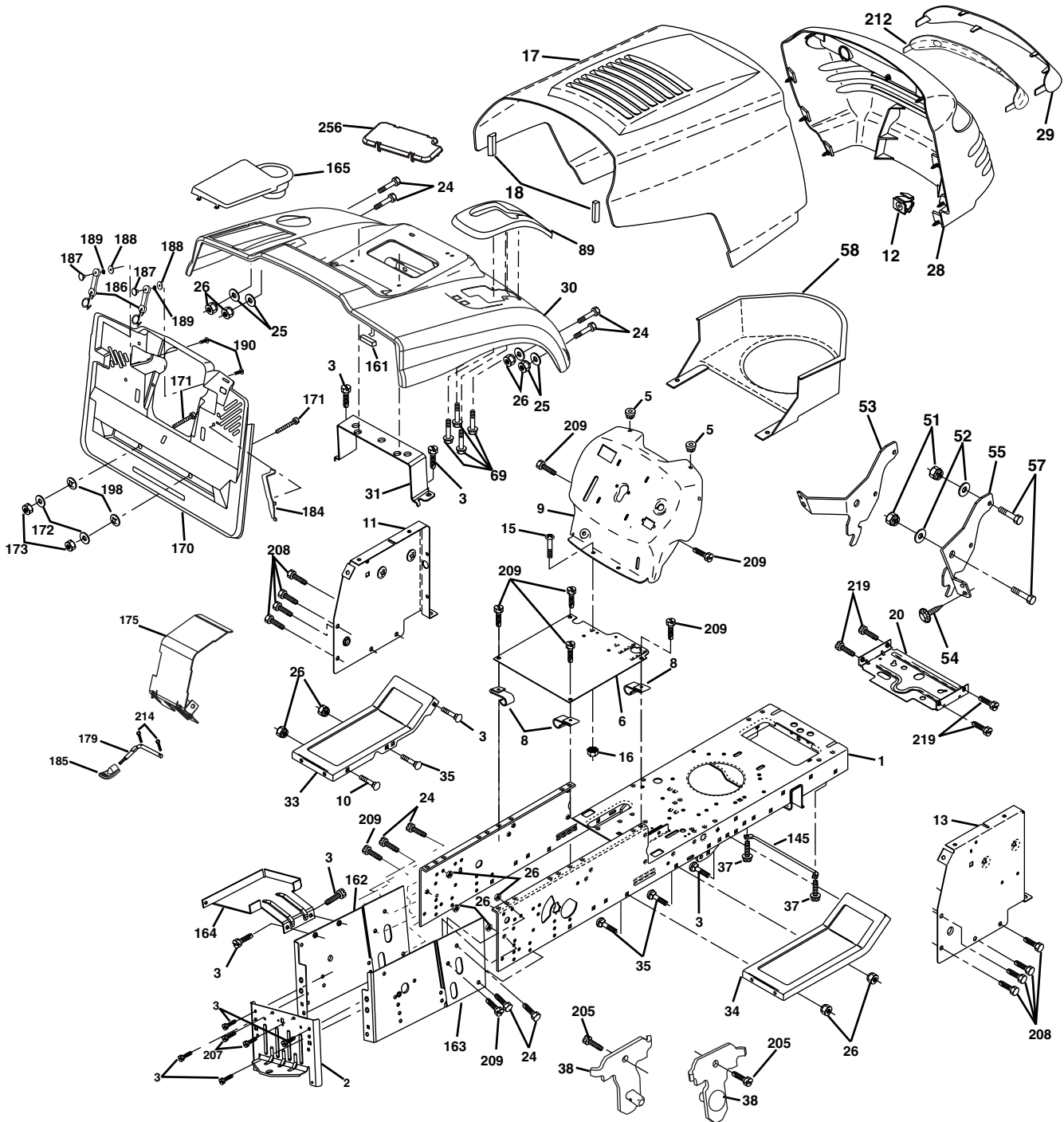

REPAIR PARTS

TRACTOR- -MODEL NO. MAC 15107-AP (MA15542RB), PRODUCT 964 77 43-00 CHASSIS AND ENCLOSURES

KEY NO.	PART NO.	DESCRIPTION	KEY NO.	PART NO.	DESCRIPTION
1	532 17 46-20	Chassis	58	532 15 01-27	Duct Air Engine
2	532 18 03-84	Drawbar	69	532 14 24-32	Screw Hex Wsh
3	817 06 06-12	Screw 3/8-16 x 3/4	89	532 18 13-88	Console
5	532 15 52-72	Bumper Hood/Dash	145	532 15 65-24	Rod Pivot Chassis/Hood
6	532 15 59-23	Saddle	161	532 16 46-55	Bumper Extrusion
8	532 12 64-71	Clip Insulator 13/32 Mtg. Hole	162	532 18 03-82	Bracket Exten Chassis Lh CRD
9	532 17 22-43	Dash	163	532 18 03-83	Bracket Exten Chassis Rh CRD
10	872 14 06-08	Bolt, Carriage 3/8-16 x 3/4	164	532 16 56-05	Support Battery CRD
11	532 17 49-96	Panel, Dash, L.H.	165	532 18 13-56	Cover Battery
12	532 14 56-60	Clip Tinnerman	170	532 17 88-62	Backplate Asm CRD
13	532 18 17-19	Panel, Asm. Dash R.H.	171	872 14 06-20	Bolt Rdhd Sqnk 3/8-16 x 2-1/2 Gr. 5
15	874 18 05-12	Screw, Machine, Truss Head 5/16-18 UNC x 3/4	172	819 13 20-16	Washer 13/32 x 1-1/4 x 16 Ga.
16	873 51 05-00	Nut	173	873 51 06-00	Nut, Keps Hex 3/8-16 UNC
17	532 18 24-04	Hood	175	532 18 03-10	Door Trap
18	532 12 69-38	Bumper Hood	179	532 18 03-76	Rod Pivot FBI CRD
20	532 18 06-79	Plate Mtg Battery/Fuel	184	532 17 46-62	Bracket Actuator Bagger CRD
24	874 78 06-16	Bolt	185	532 18 11-01	Knob Rod Brake Parking
25	819 13 13-12	Washer 13/32 x 13/16 x 12 Gauge	186	532 16 07-93	Latch Asm Mulch/Bagger
26	873 80 06-00	Nut	187	532 12 50-04	Nut Weld
28	532 17 98-45	Grille /Lens Asm	188	819 06 12-16	Washer #10
29	532 17 66-45	Lens, Grille	189	810 07 10-00	Washer Lock #10
30	532 18 24-05	Fender	190	871 08 10-10	Screw Pan Hd Phillip 10-24 x 5/8
31	532 16 51-56	Bracket, Fender Support	198	532 16 89-37	Nut, Push
33	532 18 24-06	Footrest, L.H.	205	817 49 06-08	Screw Thdrol 3/8-16 x 1/2
34	532 18 24-07	Footrest, R.H.	207	817 67 05-08	Screw 5/16-18 x 1/2
35	872 11 06-06	Bolt	208	817 67 06-08	Screw Thdrol 3/8-16 x 1/2
37	817 49 05-08	Screw Thdrol 5/16-18 x 1/2 TYT	209	817 00 06-12	Screw Hex Wsh Thdrol 3/8-16
38	532 18 17-48	Bracket Asm Pivot Mower Rear	212	532 15 62-29	Insert Lens Reflective
51	873 80 04-00	Nut Lock w/Fns 1/4-20	214	532 12 47-88	Retainer Spring
52	819 09 14-16	Washer 9/32 x 7/8 x 16 Ga.	219	817 00 05-12	Screw 5/16-18 x 3/4
53	532 14 46-97	Bracket Grille LH	256	532 18 13-61	Cover Fender Rack CRD
54	532 16 14-64	Screw Hex WSHD 8-18 x 7/8	--	532 00 54-79	Plug, Button
55	532 14 46-96	Bracket Grille RH			
57	874 78 04-12	Bolt Fins Hex 1/4-20 x 3/4			

NOTE: All component dimensions given in U.S. inches.
1 inch = 25.4 mm.

REPAIR PARTS

TRACTOR- -MODEL NO. MAC 15107-AP (MA15542RB), PRODUCT 964 77 43-00 DRIVE

KEY NO.	PART NO.	DESCRIPTION	KEY NO.	PART NO.	DESCRIPTION
1	-----	Transaxle Peerless 206-546 (Order parts from transaxle manufacturer)	82	532 16 57-11	Spring, Torsion
2	532 14 66-82	Spring Brake Return	83	819 17 12-16	Washer 17/32 x 3/4 x 16 Ga.
3	532 16 59-99	Pulley Transaxle	84	532 16 56-20	Link Shift CRD Pmst 18" Tires
4	812 00 00-28	Ring Retainer #5100-62	96	532 12 47-88	Spring, Retainer 1"
5	532 12 15-20	Strap torque 30 degrees	112	819 09 12-10	Washer 9/32 x 3/4 x 10 Ga.
8	532 16 56-19	Rod Shift Fender Adjust Lt	113	532 12 72-85	Strap torque 90 degrees
9	532 18 03-54	Clutch Asm Noram	120	873 90 06-00	Nut Lock Flg. 3/8-16 UNC
10	876 02 04-16	Pin, Cotter 1/8 x 1	145	874 49 05-40	Bolt Hex FGHD 5/16-18 x Gr 5
11	532 10 57-01	Washer Plate Shf .3888 sq hole	150	532 16 58-50	Bushing, Bellcrank Grnd Dr
13	874 55 04-12	Bolt 1/4-28 Unf Gr 8 w/patch	151	819 13 32-10	Washer 13/32 x 2 x 10 Ga.
14	810 04 04-00	Washer, Lock Hvy Helical	156	532 16 60-02	Washer Srrd 5/16 ID x 1.125
16	873 80 05-00	Nut, Lock Hex w/Ins 5/16-18 UNC	158	532 16 55-89	Bracket Shift Mount
18	874 78 06-16	Bolt Hex 3/8-16 UNC x 1 Gr.5	159	532 16 54-94	Hub Tapered Flange Shift Lt
19	873 80 06-00	Nut, Lock Hex w/Wsh 3/8-16 UNC	160	819 29 20-16	Washer 29/32 x 1-1/4 x 16 Ga.
21	532 10 69-33	Knob Rd 1/2-13 Plstc Thds Blk	161	872 14 04-06	Bolt Rdhd Sqnk 1/4-20 x 3/4 Gr 5
22	532 17 56-07	Rod, Brake CRD	162	873 68 04-00	Nut Crownlock 1/4-20 Unc
24	873 35 06-00	Nut	163	874 78 04-16	Bolt Hex Fin 1/4-20 Unc x 1 Gr 5
25	532 10 68-88	Spring, Rod, Brake	164	819 09 10-10	Washer 5/8 x .281 x 10 Ga.
26	819 13 13-16	Washer 13/32 x 13/16 x 16 Ga.	165	532 16 56-23	Bracket Pivot Lever
27	876 02 04-12	Pin, Cotter 1/8 x 3/4	166	532 16 68-80	Screw 5/16-18 x 5/8
28	532 17 57-65	Rod, Parking Brake	167	532 16 55-88	Bracket Support Shift CRD
29	532 07 16-73	Cap, Parking Brake	168	532 16 54-92	Bolt Shoulder 5/16-18 x .561
30	532 16 95-92	Bracket, Mfg. Transaxle	171	817 49 06-08	Screw Thdrol 3/8-16 x 1/2 Ty-Tt
34	532 17 55-78	Shaft, Asm Pedal Foot	172	532 16 56-35	Shaft Asm Shift Front CRD PMST
35	532 12 01-83	Bearing, Nylon	177	532 16 59-32	Keeper Flat Idler 3.06" CRD
36	819 21 16-16	Washer 21/32 x 1 x 16 Ga.	178	532 16 59-33	Keeper Belt Idler 1.88" CRD
37	532 12 49-63	Pin, Roll 3/16 x 1"	179	532 12 09-58	Washer Sintered
38	532 16 59-36	Pulley, Flat	180	532 16 56-30	Pulley Flat Idler
39	874 76 06-44	Bolt Fin Hex 3/8-16 Unc x 2-3/4	181	532 18 02-11	Bracket Idler Ground Drive CRD
40	532 12 49-65	Spacer, Split 395 x 59 Bzp	182	532 18 26-82	Keeper Belt 2.5" Od V-Idler CRD
42	819 13 13-12	Washer 13/32 x 13/16 x 12 Ga.	183	532 17 90-50	Pulley V-Idler
43	819 11 10-12	Washer 11/32 x 5/8 x 12 Ga	184	817 49 06-44	Screw Hexwsh Thdrol 3/8-16 x 2-3/4
47	532 12 77-83	Pulley, Idler, V Groove Plasitc	187	817 58 05-20	Screw thdrol 5/16-18 x 1 1/4
48	532 15 44-07	Bellcrank Clutch Grnd Drv	194	873 68 06-00	Nut Crownlock 3/8-16 UNC
49	532 12 32-05	Retainer, Belt Style Spring	202	872 11 06-14	Bolt 3/8-16 x 1 3/4 Gr. 5
50	874 76 06-24	Bolt Hex Hd 3/8-16 UNC x 1-1/2	203	871 17 07-80	Bolt Hex 7/16-20 x 5
51	873 68 06-00	Nut, Crownlock 3/8-16 UNC	214	532 17 56-09	Shaft Asm Blade
53	532 10 57-10	Link, Clutch 7.66	215	532 17 56-51	Rod Brake Secondary
55	532 10 57-09	Spring, Return, Clutch	250	817 06 06-12	Screw 3/8-16 x .75
56	817 06 06-20	Screw 3/8-16 x 1-1/4	253	532 17 50-28	Bracket Cable Chassis
57	532 16 56-31	V-Belt Kev PMST CRD	254	817 06 06-16	Screw 3/8-16 x 1
62	532 12 48-72	Cover, Pedal	255	532 17 56-08	Brace Shaft Brake Mtg.
65	810 04 07-00	Washer	258	532 17 80-62	Clip Retainer
66	532 15 47-78	Keeper, Belt Engine F-Proof	261	532 13 14-94	Pulley Idler Flt
74	532 13 70-57	Spacer Axle	263	817 00 06-12	Screw Hex Wsh Thdr 3/8-16 x 3/4
75	532 12 17-49	Washer 25/32 x 1-1/4 x 16 Ga.	264	532 18 19-95	Bracket Clutch Mounting
76	812 00 00-01	Ring, E	265	532 18 20-13	Spacer Idler Chassis
77	532 12 35-83	Key, Square	266	532 18 20-61	Shield Idler Mower
78	532 12 17-48	Washer 25/32 x 1-5/8 x 16 Ga.	267	872 14 06-26	Bolt RDHD 3/8-16unc x 3-1/4
79	532 12 50-96	Key Woodruff	268	532 18 24-03	Guard Muffler L-Head
80	532 14 50-90	Arm Shift PMST 20" Tires			

NOTE: All component dimensions given in U.S. inches
1 inch = 25.4 mm

REPAIR PARTS

TRACTOR- -MODEL NO. MAC 15107-AP (MA15542RB), PRODUCT 964 77 43-00
STEERING ASSEMBLY

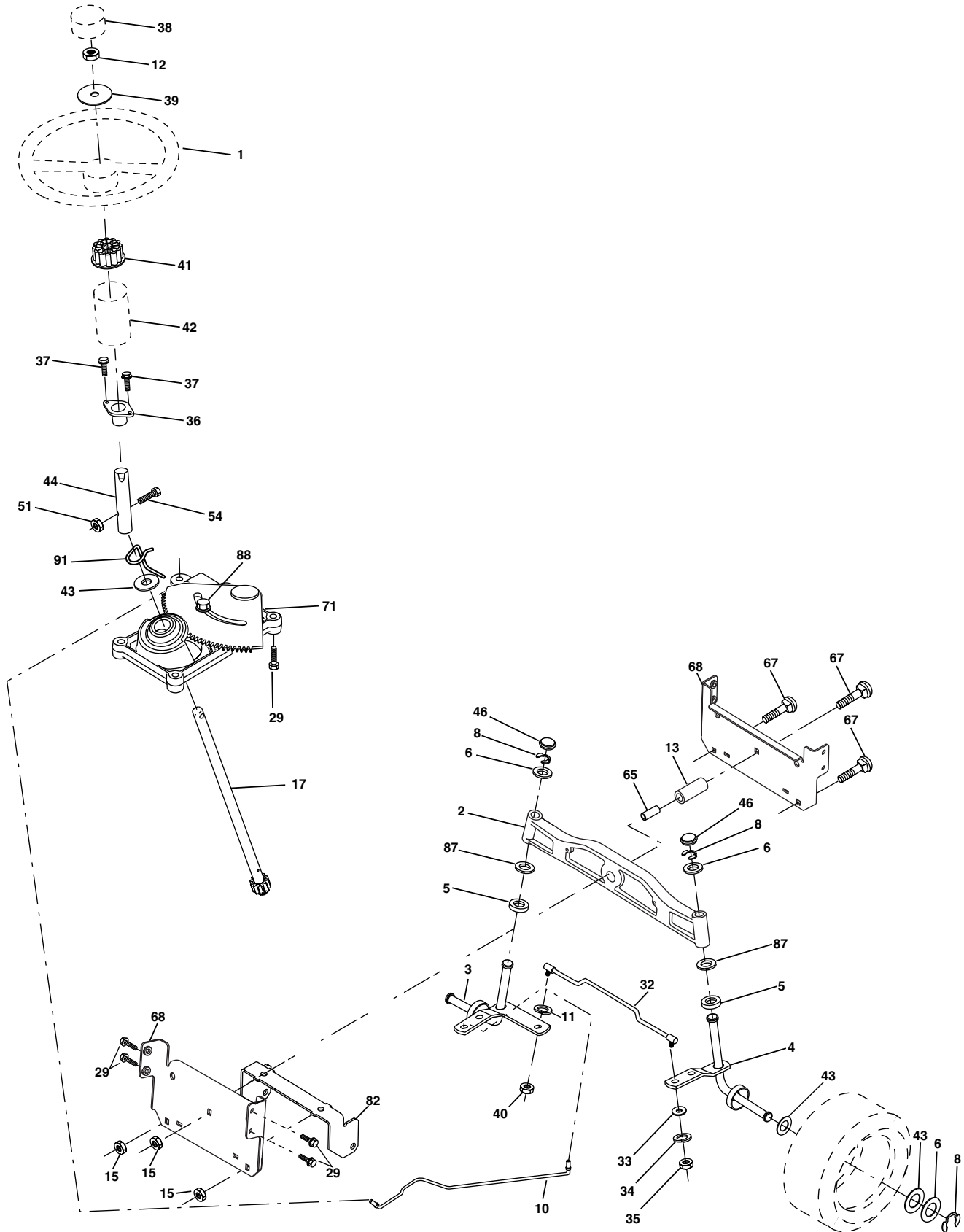

REPAIR PARTS

TRACTOR- -MODEL NO. MAC 15107-AP (MA15542RB), PRODUCT 964 77 43-00 STEERING ASSEMBLY

KEY NO.	PART NO.	DESCRIPTION
1	532 17 59-04	Steering Wheel
2	532 17 23-93	Axle Asm Cast Iron Lt
3	532 16 98-40	Spindle Assembly, L.H.
4	532 16 98-39	Spindle Assembly, R.H.
5	532 12 49-31	Washer, Thrust .75 x 1.230
6	532 12 17-48	Washer 25/32 x 1-5/8 x 16 Gauge
8	812 00 00-29	Ring, Klip
10	532 17 51-21	Link, Drag
11	810 04 06-00	Washer, Lock
12	873 94 08-00	Nut Hex Jam Toplock 1/2-20 UNF
13	532 13 65-18	Spacer Brg Axle Front
15	532 14 52-12	Nut, Hex Flange Lock
17	532 18 06-41	Shaft Assembly, Steering
29	817 06 06-12	Screw 3/8-16 x 3/4
32	532 17 01-62	Rod, Tie
33	819 11 12-16	Washer 11/32 x 3/4 x 16 Ga.
34	810 04 05-00	Washer Lock Hvy Hlcl Spr 5/16
35	873 54 05-00	Crownlock Nut 5/16-24 Unf
36	532 15 50-99	Bushing, Steering
37	532 15 29-27	Screw TT #10-32 x 5 x 3/8 Flange
38	532 17 59-05	Cap Wheel Steering
39	819 18 38-12	Washer 9/16 ID x 2-3/8 OD 12 Ga.
40	532 12 47-01	Nut Lock Center 3/8-24 Unf
41	532 10 07-11	Adaptor, Steering Wheel
42	532 16 96-33	Boot, Steering Dash P/L Mtl
43	532 12 17-49	Washer 25/32 x 1-1/4 x 16 Gauge
44	532 18 06-40	Extension Steering
46	532 12 12-32	Cap, Spindle
51	873 54 04-00	Nut Crownlock 1/4-28
54	871 13 04-20	Bolt Hex 1/4-28 UNF x 1-1/4 Gr 8
65	532 16 03-67	Spacer Brace Axle
67	872 14 06-18	Bolt Rdhd Sq 3/8-16 x 2-1/4
68	532 16 98-27	Brace Axle
71	532 17 51-46	Steering Asm.
82	532 16 98-35	Bracket Susp Chassis Front 15"
87	532 17 39-66	Washer Flat .781 x 1-1/2 x .14
88	532 17 51-18	Bolt Shoulder 7/16-20 UNC
91	532 17 55-53	Clip Steering

NOTE: All component dimensions given in U.S. inches.
1 inch = 25.4 mm.

REPAIR PARTS

TRACTOR- -MODEL NO. MAC 15107-AP (MA15542RB), PRODUCT 964 77 43-00 SEAT ASSEMBLY

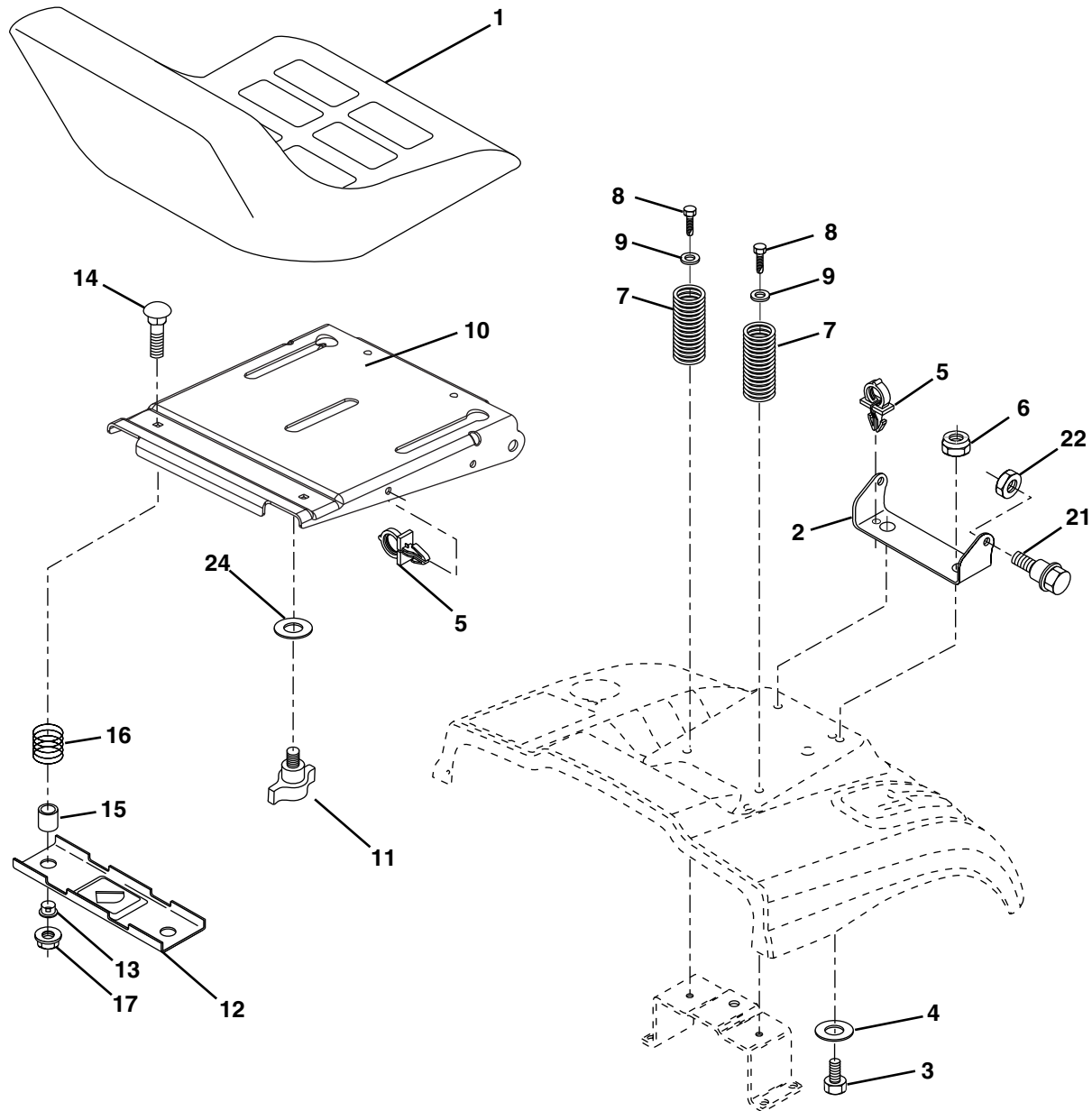

KEY NO.	PART NO.	DESCRIPTION
1	532 1274-27	Seat
2	532 1405-51	Bracket Pnt Pivot Seat (blk)
3	871 1106-16	Bolt Fin Hex 3/8-16 UNC x 1
4	819 1316-10	Washer Flat 13/32 x 1 x 10 Ga
5	532 1450-06	Clip Push In Hinged
6	873 8006-00	Nut Lock Hex w/Ins 3/8-16 UNC
7	532 1241-81	Spring Seat Cprsn 2 250 Blk Zi
8	817 0006-16	Screw 3/8-16 X 1-1/2
9	819 1316-14	Washer 13/32 X 1 X 14 Ga
10	532 1824-93	Pan Assembly Seat Tool-Free
11	532 1663-69	Knob Seat Adj. Wingnut
12	532 1212-46	Bracket Pnt Mounting Switch

KEY NO.	PART NO.	DESCRIPTION
13	532 1212-48	Bushing Snap Blk Nyl 50 Id
14	872 0504-12	Bolt Rdhd Sht Nk 1/4-20x1-1/2
15	532 1343-00	Spacer Split
16	532 1212-50	Spring Cprsn 1.27 Blk
17	532 1239-76	Nut Lock 1/4 Lge Flg Gr 5 Zinc
21	532 1718-52	Bolt Shoulder 5/16-18 Unc-2A
22	873 8005-00	Nut Hex Lock w/Ins 5/16-18
24	819 1719-12	Washer 17/32 X 1-3/16 X 12 Ga.
25	532 1270-18	Bolt Shoulder 5/16-18 X 62

NOTE: All component dimensions given in U.S. inches.
1 inch = 25.4 mm

REPAIR PARTS

TRACTOR- -MODEL NO. MAC 15107-AP (MA15542RB), PRODUCT 964 77 43-00
DECALS

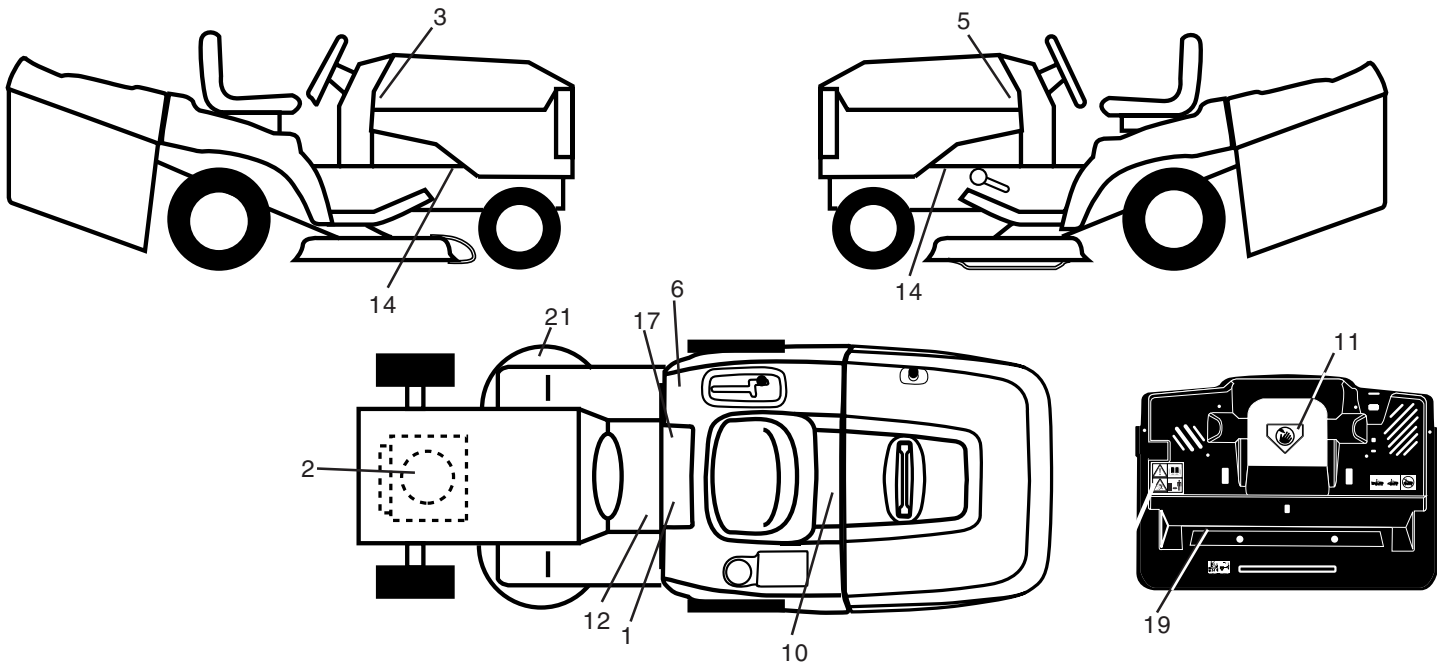

KEY NO.	PART NO.	DESCRIPTION
1	532 14 54-98	Decal Read Owner's Manual Sym
2	532 17 63-98	Decal Hp Engine
3	532 18 18-28	Decal Hood RH
5	532 18 18-29	Decal Hood LH
6	532 18 04-32	Decal 100 DBA
10	532 14 50-05	Decal Bat Dan/Poi P/L Sym Wpn
11	532 18 21-66	Decal Mower Cut Finger Symbol
12	532 15 97-37	Decal Brake/Clutch Symbol Lt
14	532 15 97-36	Decal Chassis Hot Muffler

KEY NO.	PART NO.	DESCRIPTION
17	532 14 08-37	Decal Saddle Brake Parking
19	532 18 04-35	Decal Backplate CRD Symbols
21	532 16 62-86	Decal Deck Sch
—	532 13 83-11	Decal Lift Handle
—	532 18 10-90	Pad Footrest R.H.
—	532 18 10-91	Pad Footrest L.H.
—	532 18 26-21	Decal Bagger Frame Assy
—	532 18 36-01	Manual Operator's (Euro)
—	532 18 36-02	Manual Operator's (Scan)

WHEELS & TIRES

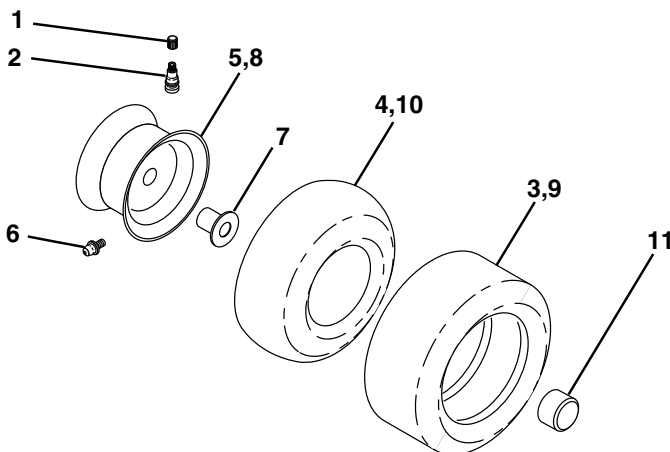

KEY NO.	PART NO.	DESCRIPTION
1	532 05 91-92	Cap Value Tire
2	532 06 51-39	Stem Value
3	532 10 62-22	Tire F Ts 15 X 6 0 - 6 Service
4	532 05 99-04	Tube Inner Front #35060
5	532 18 24-00	Rim Asm 6" front Service
6	532 12 49-57	Fitting Grease
7	532 12 49-59	Bearing Flange
8	532 18 24-01	Rim Asm 8" rear Service
9	532 13 84-68	Tire R Ts 20 x 8-8 Service
10	532 12 49-26	Tube Rear 9 5 X 8 Service
11	532 17 50-39	Cap Axle Blk 1 50 X 1 00
--	532 14 43-34	Sealant, Tire (10 oz. tube)

NOTE: All component dimensions given in U.S. inches
1 inch = 25.4 mm

REPAIR PARTS

TRACTOR- -MODEL NO. MAC 15107-AP (MA15542RB), PRODUCT 964 77 43-00
ENGINE

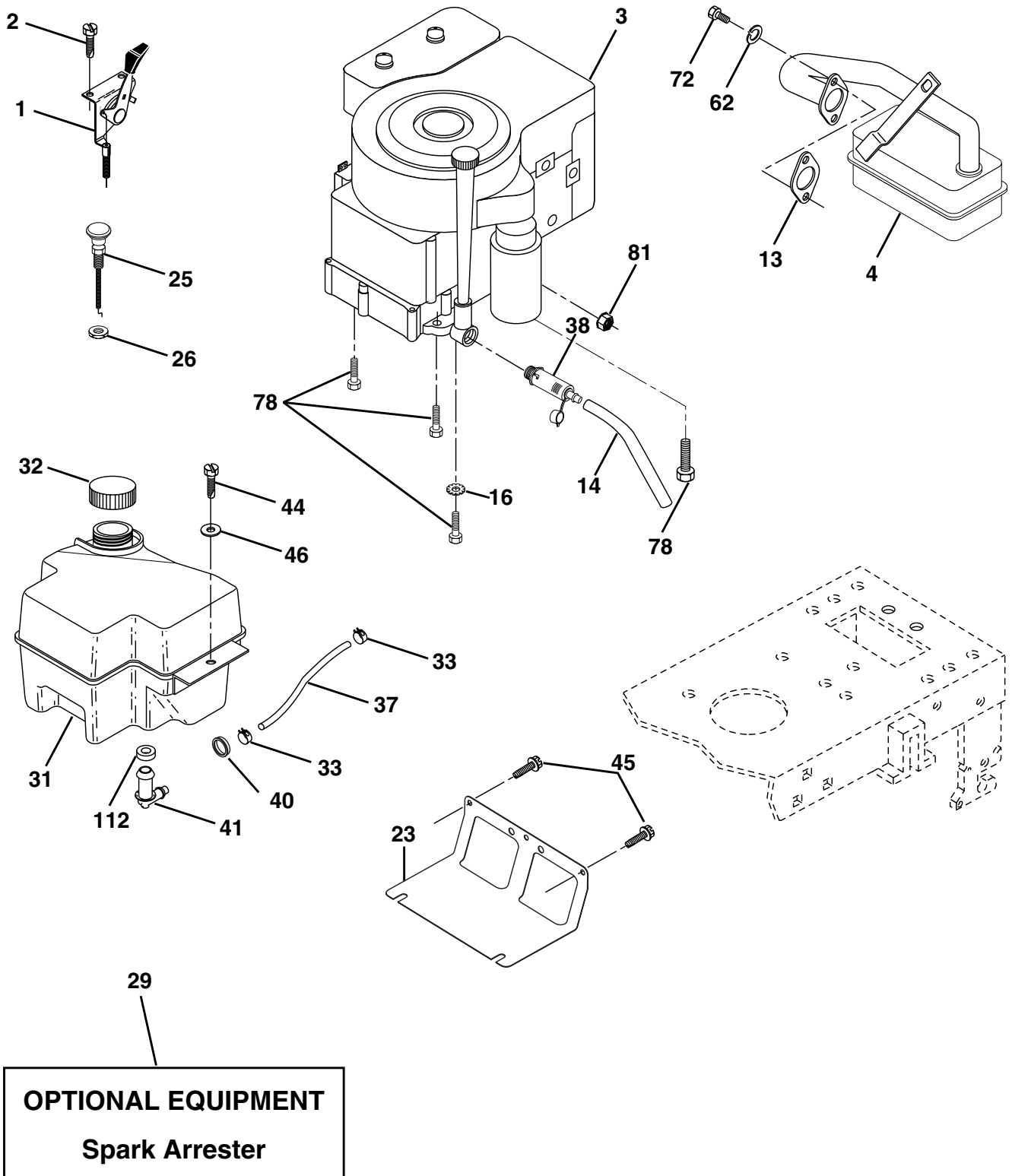

REPAIR PARTS

TRACTOR- -MODEL NO. MAC 15107-AP (MA15542RB), PRODUCT 964 77 43-00
ENGINE

KEY NO.	PART NO.	DESCRIPTION
1	532 17 05-51	Control Throt/Ch
2	817 72 04-08	Screw Hex Thd Cut 1/4-20 x 1/2
3	-----	Engine Briggs Model 28U707 (Order Parts from Engine Manufacturer)
4	532 13 73-52	Muffler
13	532 16 52-91	Gasket 1 313 Id Tin Plated
14	532 14 84-56	Tube Drain Oil Easy
16	811 05 06-00	Washer Lock Ext Tooth 3/8
23	532 16 98-37	Shield Browning/Debris Guard
25	532 18 09-45	Control Choke
26	873 92 06-00	Nut Keps 3/8-24 Unf
29	532 13 71-80	Arrestor Spark
31	532 18 06-45	Tank Fuel
32	532 14 05-27	Cap Asm Fule Top Vent N/Lany
33	532 12 34-87	Clamp Hose Blk
37	532 13 70-40	Line Fuel 20"
38	532 14 83-15	Oil Drain Plug Easy
40	532 12 40-28	Bushing Snap
41	532 13 92-77	Stem Tank Fuel
44	817 67 04-12	Screw Hexwsh Thdrol 1/4-20x3/4
45	817 00 06-12	Screw Hexwsh Thdrol 3/8-16 x 3/4
46	819 09 14-16	Washer 9/32 X 7/8 X 16ga
62	810 04 05-00	Washer Lock Hvy Hlcl Spr 5/16
72	871 07 05-12	Screw Hex Hd Cap 5/16-18 x 3/4
78	817 06 06-20	Screw 3/8-16x1-1/4
81	873 51 04-00	Nut Keps Hex 1/4-20 Unc
112	532 00 36-45	Bushing

NOTE: All component dimensions given in U.S. inches
1 inch = 25.4 mm

REPAIR PARTS

TRACTOR- -MODEL NO. MAC 15107-AP (MA15542RB), PRODUCT 964 77 43-00
MOWER LIFT

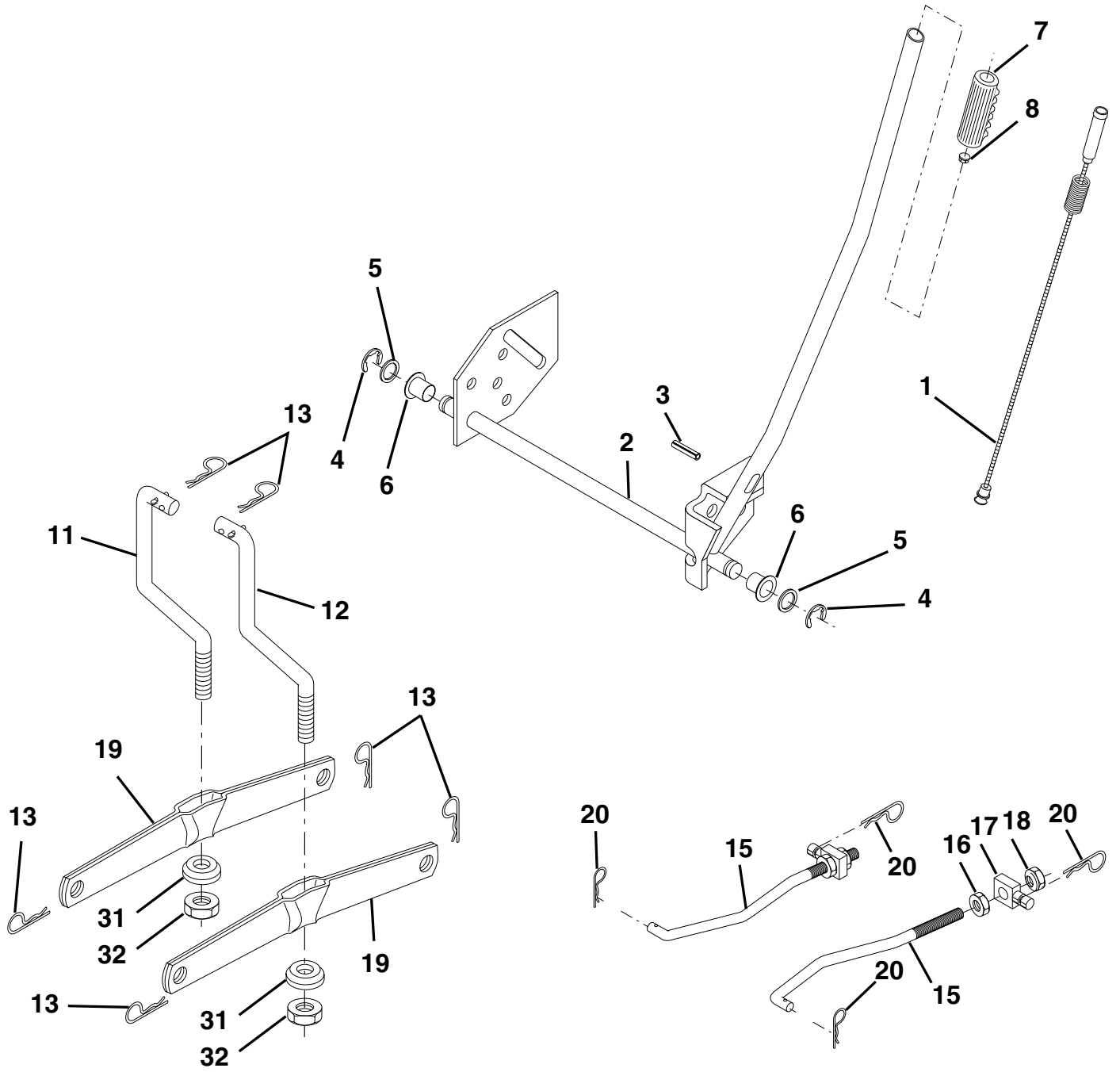

REPAIR PARTS

TRACTOR- -MODEL NO. MAC 15107-AP (MA15542RB), PRODUCT 964 77 43-00
MOWER LIFT

KEY NO.	PART NO.	DESCRIPTION
1	532 15 94-60	Washer Asm Inner Spring W/Plunger
2	532 15 94-71	Shaft Asm. Lift
3	532 10 57-67	Pin Groove
4	812 00 00-02	E Ring #5133-62
5	819 21 16-21	Washer 21/32 x 1 x 21 Ga.
6	532 12 01-83	Bearing Nylon
7	532 10 94-13	Grip Handle
8	532 12 45-26	Button Plunger Black
11	532 16 58-29	Link Asm Lift L.H.
12	532 16 58-31	Link Asm Lift R.H.
13	532 12 46-70	Retainer Spring
15	532 17 32-88	Link Front
16	873 35 08-00	Nut Jam Hex 1/2-13 Unc
17	532 17 56-89	Trunnion
18	873 80 08-00	Nut Lock w/Wsh 1/2-13 Unc
19	532 13 98-68	Arm Suspension Mower
20	532 16 35-52	Retainer Spring
31	532 16 98-65	Bearing, Pvt. Lift.
32	873 54 06-00	Nut Crownlock 3/8-24

NOTE: All component dimensions given in U.S. inches
1 inch = 25.4 mm

REPAIR PARTS

**TRACTOR- -MODEL NO. MAC 15107-AP (MA15542RB), PRODUCT 964 77 43-00
MOWER**

KEY NO.	PART NO.	DESCRIPTION	KEY NO.	PART NO.	DESCRIPTION
1	532 1691-60	Housing Asm. Mower	44	532 17 55-38	Cover Mandrel Lh
2	872 14 05-06	Bolt Rdhd Sqnk 5/16-18 Unc x 3/4	45	532 17 55-39	Cover Mandrel Rh
3	532 16 55-69	Bracket Asm. S-Bar Chass	46	532 13 77-29	Screw Thd Roll 1/4-20 x 5/8
4	532 1691-67	Bracket Bar Sway Deck	55	532 16 98-49	Arm Idler 107 CRD
5	532 12 46-70	Retainer Spring	61	532 17 51-59	Spring Tension Belt
6	532 16 55-57	Bar Sway	67	532 10 69-32	Knob Rd 3/8-16 Plstc Thds Blk
8	532 18 17-12	Bolt 3/8-24 x 1.25 Gr8 Patched	68	532 16 91-78	Hex-Belt Mower
9	810 03 06-00	Washer Lock Hvy 3/8 Unplated	69	532 16 54-82	Shaft Asm W/Lwr Brg Rh Thd CRD
11	532 18 05-83	Blade 3-1 Lh	84	532 15 60-85	Keeper Belt Idler
13	532 13 76-45	Shaft Asm. W/Lower Bearing	116	532 13 76-44	Bolt Shoulder
14	532 12 87-74	Housing Mandrel Vented (Machd)	117	532 13 39-57	Wheel Gage Donut Wide
15	532 11 04-85	Bearing Ball Mandrel	118	873 93 06-00	Nut Centerlock 3/8-16 Unc
16	532 18 05-83	Blade 3-1 Rh	119	819 12 14-14	Washer 3/8 x 7/8 x 14 Ga.
19	532 13 28-27	Bolt Shoulder 5/16-18 Thd Form	124	872 11 06-12	Bolt Carr Sh 3/8-16 x 1-1/2 Gr5
20	532 18 17-13	Bolt 3/8-24 x 1.25 Gr8 Ptch Lhthd	130	872 11 05-06	Bolt Rdhdsqnk 5/16-18 Unc x 3/4
21	873 68 05-00	Nut Crown Lock 5/16-18	131	532 16 56-61	Chute Bagger CRD
22	532 16 91-65	Bracket Idler RR	151	532 16 96-70	Bracket Clutch Cable
23	532 16 91-66	Bracket Idler RF	152	532 17 60-74	Cable Clutch CRD Service
24	532 16 91-70	Bracket Suspension LF	153	532 16 96-74	Washer Flat 3/8" Type B
25	532 16 91-71	Bracket Suspension RF	154	532 16 96-75	Spring Retainer
26	532 16 52-37	Brace Support Susp Frt CRD	155	532 16 96-71	Spring Retention Lvr Cltch Cab
27	532 16 91-72	Bracket Asm. Susp RR	156	532 16 96-72	Spacer Clutch Cable
28	532 16 91-68	Bracket Asm. Susp LR	157	532 16 96-69	Rod Clutch Cable 3/8"
30	532 17 39-84	Screw Thd Rolling Dod Pt	158	817 72 04-08	Screw Hex Thd Cut 1/4-20 x 1/2
31	532 12 99-63	Washer Spacer Mower Vented	161	532 18 04-24	Blade Cross LH
32	532 17 57-07	Mandrel Pulleys	162	532 18 08-78	Adapter Weldment Blade
33	532 17 83-42	Nut Flg Top Lock	163	532 18 04-25	Blade Cross RH
34	532 17 95-09	Bracket Gauge Wheel Lf	-	532 18 18-57	Mandrel Assembly (Includes Housing, Shaft and Shaft Hardware Only - Pulley Not Included)
35	532 17 62-92	Bracket Gauge Wheel Rf	-	532 18 18-58	Mandrel Asm CRD Lh Threads SVC
36	532 14 67-63	Pulley Idler V-Groove Dim 4.25	-	532 18 17-70	Replacement Mower Complete
37	819 13 13-16	Washer 11/32 x 13/16 x 16 Ga			
38	532 16 98-51	Spacer Hub Arm Idler 107 CRD			
39	872 11 06-22	Bolt Crownlock 3/8-16 Unc			
40	873 68 06-00	Nut Crownlock 3/8-16 Unc			

NOTE: All component dimensions given in U.S. inches
1 inch = 25.4 mm

REPAIR PARTS

TRACTOR- -MODEL NO. MAC 15107-AP (MA15542RB), PRODUCT 964 77 43-00
BAGGER

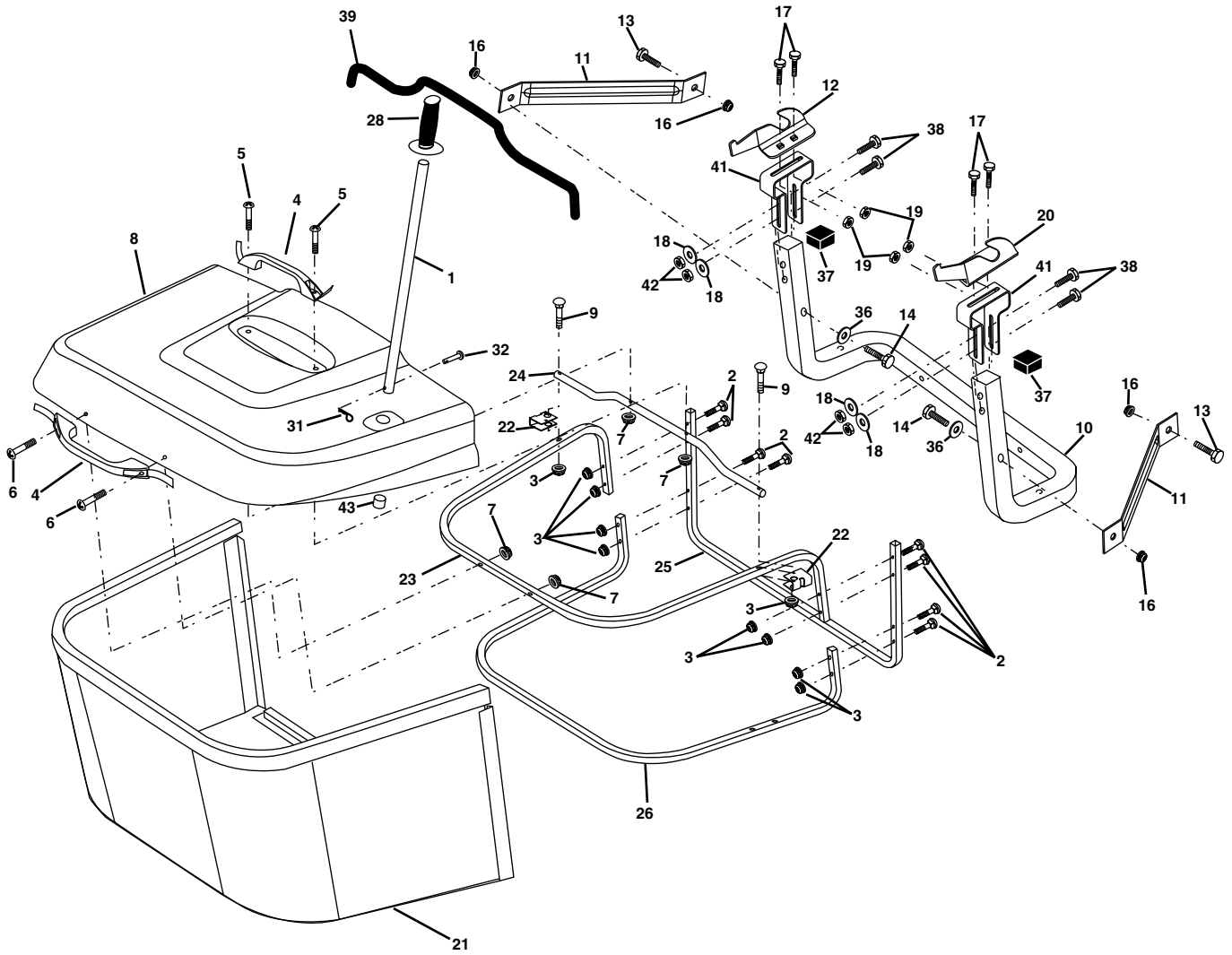

REPAIR PARTS

TRACTOR- -MODEL NO. MAC 15107-AP (MA15542RB), PRODUCT 964 77 43-00
BAGGER

KEY NO.	PART NO.	DESCRIPTION
1	532 1652-49	Tube Handle Bagger CRD
2	872 14 04-16	Bolt Carriage 1/4-20 x 2.0 Gr.5
3	532 12 39-76	Nut Lock 1/4 Lge Flg Gr. 5 Zinc
4	532 16 99-16	Handle Bagger w/Lvrs Blk CRD
5	874 98 10-24	Screw Pan Head #10-24 x 1.50 Blk
6	874 98 10-32	Screw Pan Hd
7	873 40 10-00	Nut Wiz Lock Hex Serr/Hd 10-24
8	532 18 24-08	Cover Bagger
9	872 14 04-18	Bolt Carriage 1/4-20 x 2.25d x Gr.5
10	532 18 12-82	Tube Support Bagger CRD
11	532 16 57-19	Bracket Support Upper Bag CRD
12	532 16 96-85	Bracket Horizon Adj Bggr Lh CRD
13	872 11 06-06	Bolt Rdhd Sht Sqnk 3/8-16 x 3/4
14	874 52 06-36	Bolt Hex Fin 3/8-16 x 2-1/4 Gr.5
16	873 90 06-00	Nut Lock Flg 3/8-16 Unc
17	872 14 05-06	Bolt Rdhd Sht Sqnk 5/16 -18 Unc x 3/4
18	819 11 12-16	Washer 11/32 x 3/4 x 16 Ga.
19	873 90 05-00	Nut Lock Hex Flange 5/16-18
20	532 16 96-84	Bracket Horiz Adj Bggr RH CRD
21	532 18 08-80	Bag Asm CRD
22	532 16 57-81	Bracket Side Bagger CRD
23	532 16 57-82	Tube Upper Bagger CRD
24	532 16 57-83	Tube Pivot Bagger CRD
25	532 18 01-24	Tube Front Bagger CRD
26	532 16 57-85	Tube Lower Bagger CRD
28	532 16 57-87	Grip Handle Black
31	532 12 47-88	Retainer Spring 1" Zinc/Cad
32	532 12 68-75	Rivet Rd Hd Drilled 3/8 Dia
36	819 13 20-16	Washer 13/32 x 1-1/4 x 16 Ga.
37	532 17 54-01	Plug Suport Bagger CRD
38	872 01 05-20	Bolt 5/16-18 x 2-1/2
39	532 18 09-85	Seal 37"
41	532 16 96-83	Bracket Vert Adj Bagger CRD
42	873 80 05-00	Nut Lock Hex W/Ins 5/16-18 Unc Pl
43	532 17 40-83	Plug Tubing End

NOTE: All component dimensions given in U.S. inches
1 inch = 25.4 mm

TRACTOR- -MODEL NO. MAC 15107-AP (MA15542RB), PRODUCT 964 77 43-00 SCHEMATIC

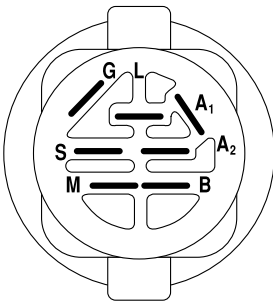
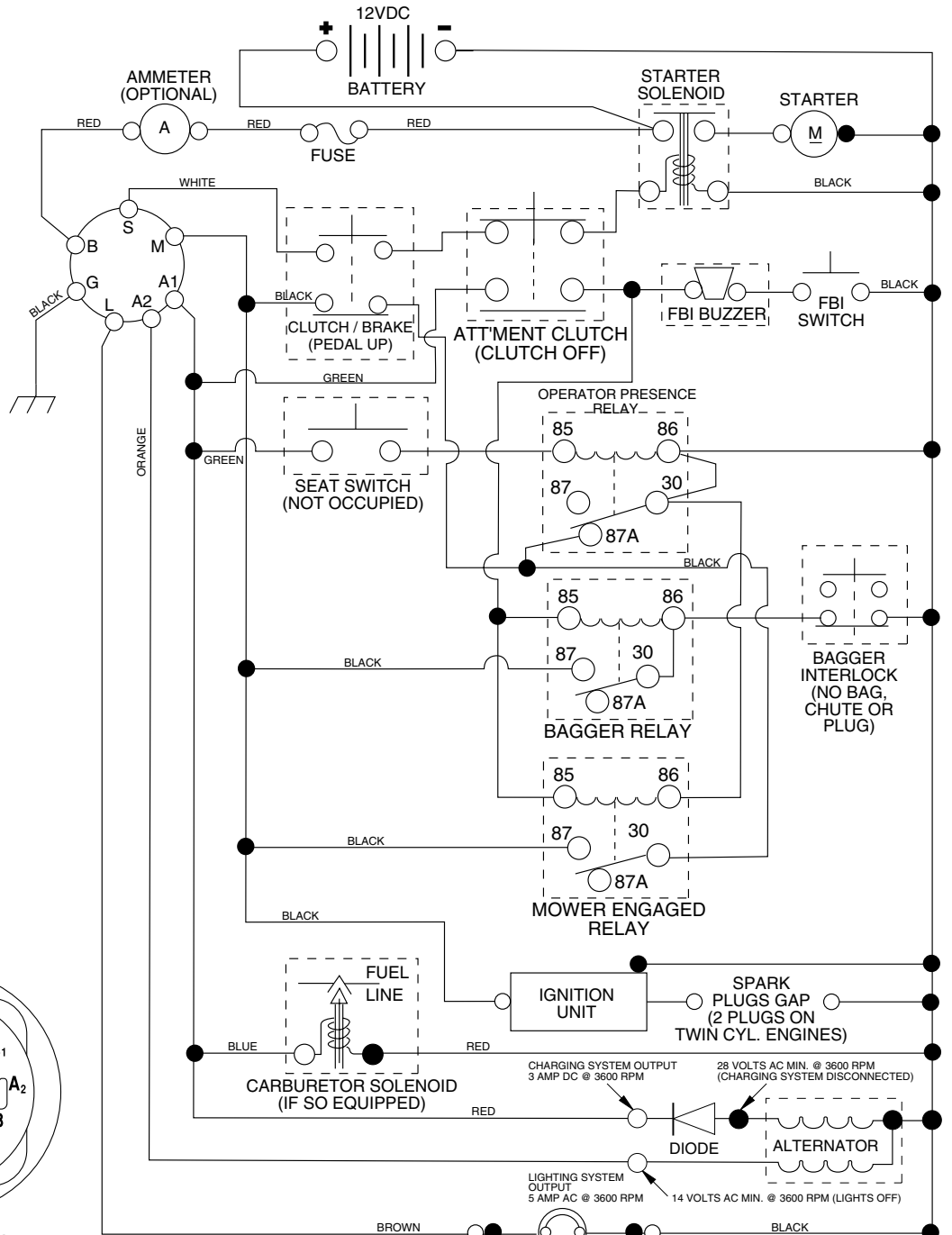

IGNITION SWITCH

POSITION	CIRCUIT	"MAKE"
OFF	M+G+A1	NONE
RUN/LIGHT	B+A1	A2+L
RUN	B+A1	NONE
START	B + S + A1	NONE

WIRING INSULATED CLIPS
NOTE: IF WIRING INSULATED CLIPS WERE REMOVED FOR SERVICING OF UNIT, THEY SHOULD BE REPLACED TO PROPERLY SECURE YOUR WIRING.



PTO SWITCH

POSITION	CIRCUIT
OFF	C + G, B + H
ON	C + F, B + E, A + D

HEADLIGHTS

NOTE
YOUR TRACTOR IS EQUIPPED WITH A SPECIAL ALTERNATOR SYSTEM. THE LIGHTS ARE NOT CONNECTED TO THE BATTERY, BUT HAVE THEIR OWN ELECTRICAL SOURCE. BECAUSE OF THIS, THE BRIGHTNESS OF THE LIGHTS WILL CHANGE WITH ENGINE SPEED. AT IDLE THE LIGHTS WILL DIM. AS THE ENGINE IS SPEEDED UP, THE LIGHTS WILL BECOME THEIR BRIGHTEST.

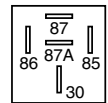

RELAY

