

**REPAIR PARTS MANUAL**  
**MODEL NO. MJ15B97 (96011022900)**  
**Lawn Tractor**

---



**Mr. JARDINAGE**

# HOW TO USE THIS MANUAL

This manual is designed to provide the customer with a means to identify the parts on his/her tractor when ordering repair parts. The illustrations may or may not represent the actual assemblies; therefore, it is not recommended to use this manual as a guide to assemble or disassemble the tractor. Some hardware and parts are drawn larger in order to more readily identify them.

Each tractor has its own model number.

The model number for your tractor can be found on the fender under the seat.

When ordering parts, always give the following information:

- Product - "Lawn Tractor"
- Model Number - "MJ15B97" (96011022900)
- Part Number
- Part Description

## TABLE OF CONTENTS

<b>SCHEMATIC .....</b>	<b>3</b>
<b>ELECTRICAL.....</b>	<b>4-5</b>
<b>CHASSIS AND ENCLOSURES.....</b>	<b>6-7</b>
<b>DRIVE.....</b>	<b>8-9</b>
<b>STEERING ASSEMBLY.....</b>	<b>10-11</b>
<b>SEAT ASSEMBLY .....</b>	<b>12</b>
<b>DECALS.....</b>	<b>13</b>
<b>ENGINE.....</b>	<b>14-15</b>
<b>MOWER DECK .....</b>	<b>16-17</b>
<b>LIFT .....</b>	<b>18-19</b>

# TRACTOR - MODEL NO. MJ15B97 (96011022900), PRODUCT NO. 960 11 02-29 SCHEMATIC

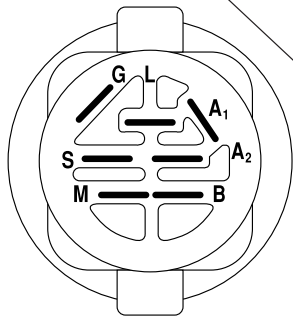
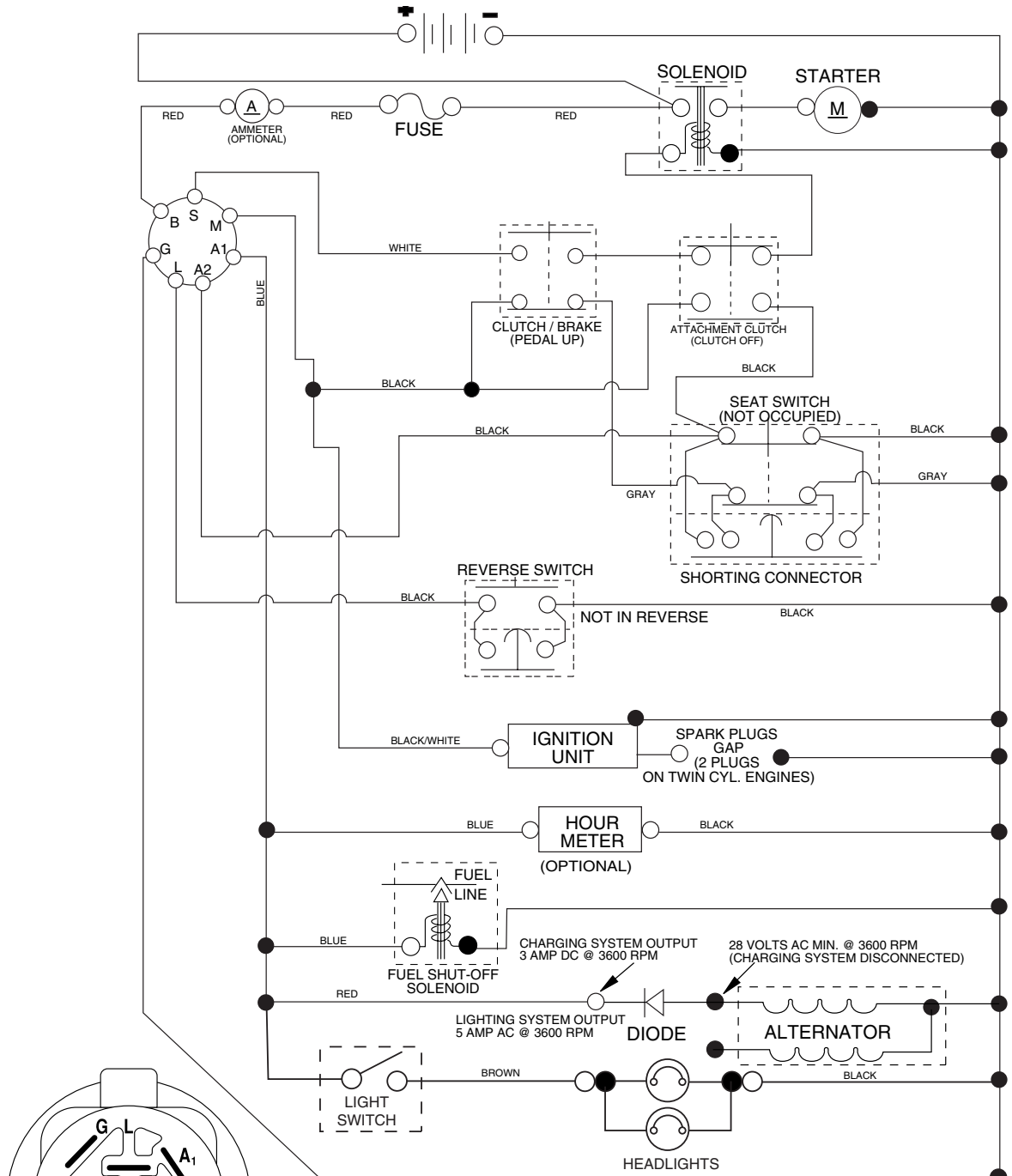

**IGNITION SWITCH**

POSITION	CIRCUIT "MAKE"
OFF	M+G+A1
RUN/OVERRIDE	B+A1
RUN	B+A1 L+A2
START	B + S + A1

03059

**NOTE**

YOUR TRACTOR IS EQUIPPED WITH A SPECIAL ALTERNATOR SYSTEM. THE LIGHTS ARE NOT CONNECTED TO THE BATTERY, BUT HAVE THEIR OWN ELECTRICAL SOURCE. BECAUSE OF THIS, THE BRIGHTNESS OF THE LIGHTS WILL CHANGE WITH ENGINE SPEED. AT IDLE THE LIGHTS WILL DIM. AS THE ENGINE IS SPEEDED UP, THE LIGHTS WILL BECOME THEIR BRIGHTEST.

●  
NON-REMOVABLE CONNECTIONS

○  
REMOVABLE CONNECTIONS

**WIRING INSULATED CLIPS**

**NOTE:** IF WIRING INSULATED CLIPS WERE REMOVED FOR SERVICING OF UNIT, THEY SHOULD BE REPLACED TO PROPERLY SECURE YOUR WIRING.

# REPAIR PARTS

TRACTOR - MODEL NO. MJ15B97 (96011022900), PRODUCT NO. 960 11 02-29  
ELECTRICAL

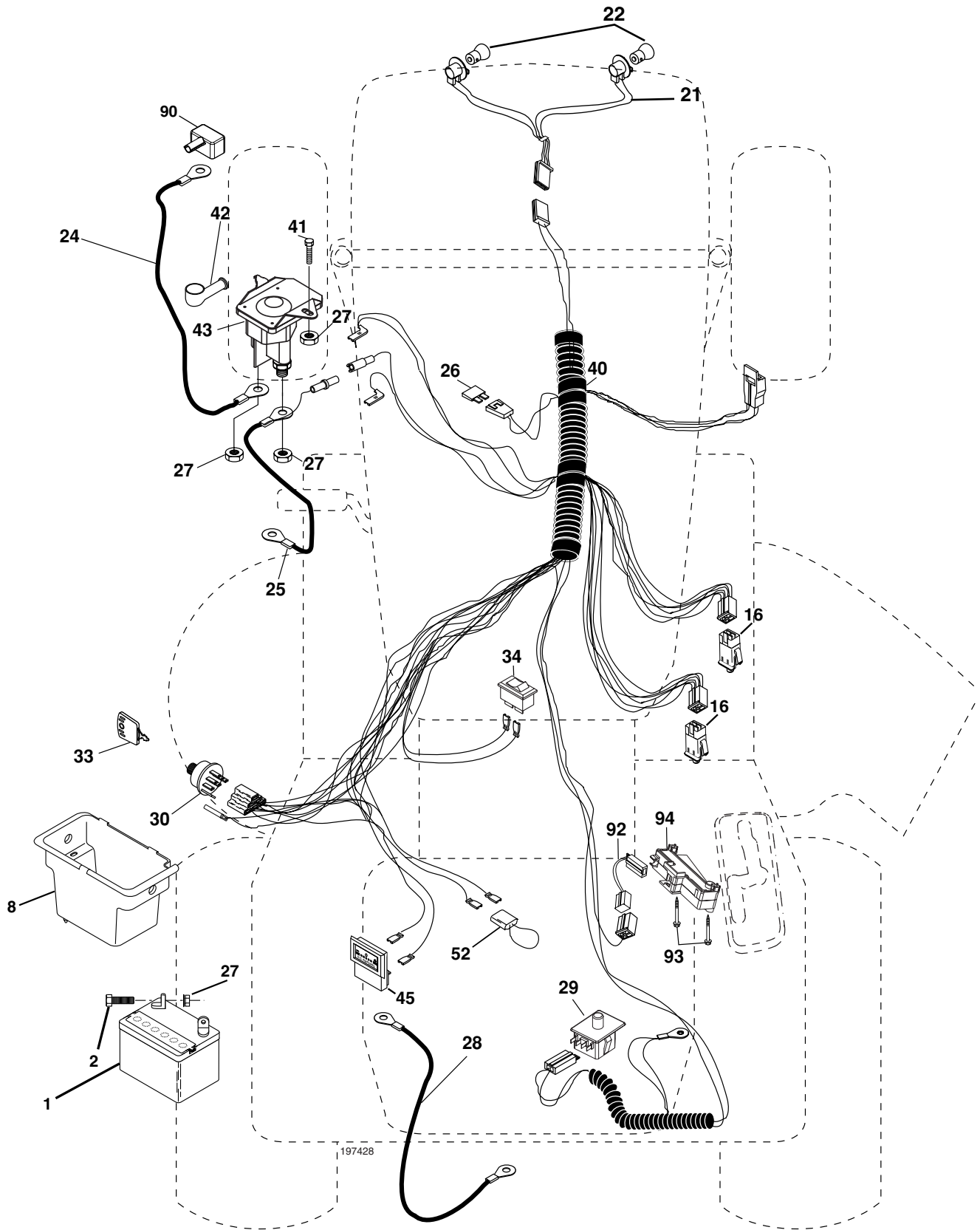

197428

# REPAIR PARTS

TRACTOR - MODEL NO. MJ15B97 (96011022900), PRODUCT NO. 960 11 02-29  
ELECTRICAL

KEY NO.	PART NO.	DESCRIPTION
1	532 16 34-65	Battery 12 Volt 25 AMP
2	874 76 04-12	Bolt Hex Hd 1/4-20 unc x 3/4
8	532 17 66-89	Box Battery
16	532 17 61-38	Switch Interlock Push-In
21	532 18 37-59	Harness Asm Light
22	532 00 41-52	Bulb Light
24	532 12 47-80	Cable Battery 6 Ga. 11" red
25	532 14 61-47	Cable Battery 6 Ga. 44" red w/16 wire
26	532 17 51-58	Fuse 20 AMP
27	873 51 04-00	Nut Keps Hex 1/4-20 unc
28	532 12 47-73	Cable Ground 6 Ga. 12" black
29	532 19 27-49	Switch Seat
30	532 19 33-50	Switch Ign
33	532 14 04-01	Key Ign Molded Generic
34	532 11 07-12	Light Switch
40	532 19 74-28	Harness Ign.
41	871 11 04-08	Bolt Blk Fin Hex 1/4 - 20 x 1/2
42	532 13 15-63	Cover Terminal Red
43	532 19 25-07	Solenoid
45	532 12 14-33	Ammeter Rectangular
52	532 14 19-40	Protection Wire Loop
90	532 18 04-49	Cover Terminal Battery
92	532 19 66-15	Harness Pigtail Consle ROS
93	532 19 25-40	Screw Plastic 10-14 x 2.0
94	532 19 18-34	Module Reverse ROS

**NOTE:** All component dimensions given in U.S. inches.  
1 inch = 25.4 mm.

# REPAIR PARTS

TRACTOR - MODEL NO. MJ15B97 (96011022900), PRODUCT NO. 960 11 02-29  
CHASSIS AND ENCLOSURES

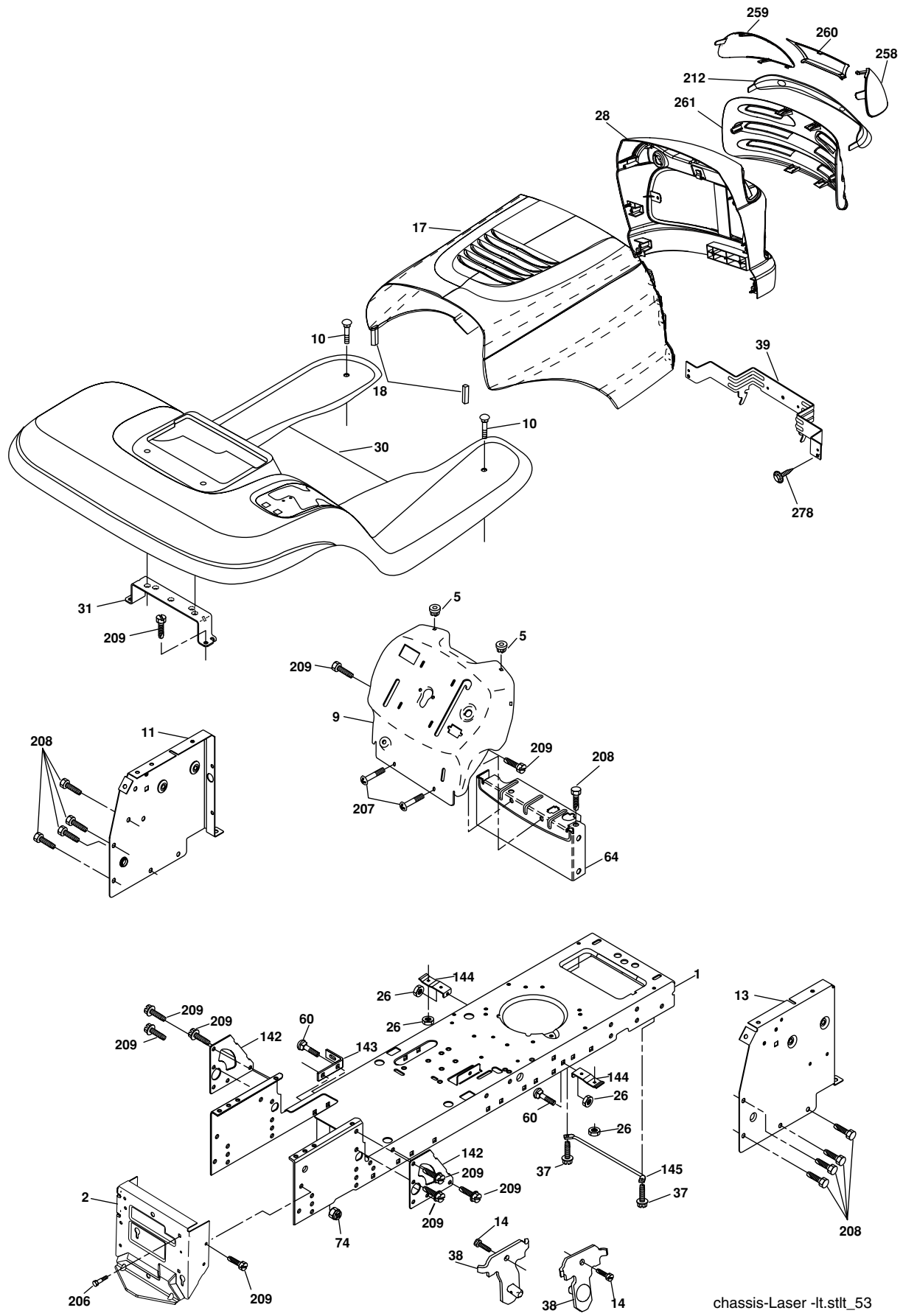

# REPAIR PARTS

## TRACTOR - MODEL NO. MJ15B97 (96011022900), PRODUCT NO. 960 11 02-29 CHASSIS AND ENCLOSURES

KEY NO.	PART NO.	DESCRIPTION
1	532 17 46-19	Chassis Stamping
2	532 17 65-54	Drawbar
5	532 15 52-72	Bumper Hood/Dash
9	532 19 68-36	Dash P/L
10	872 14 06-08	Bolt Carriage 3/8-16 x 1
11	532 17 49-96	Panel Dash Lh
13	532 18 17-19	Panel Dash Rh
14	817 49 06-08	Screw Thdrol 3/8-16 x 1/2
17	532 40 38-31	Hood
18	532 18 49-21	Bumper Hood
26	873 80 06-00	Nut Lock Hex W/Ins 3/8-16 unc
28	532 40 34-89	Grille/Lens (Includes key nos. 212,258,259,260 & 261)
30	532 40 38-32	Fender Footrest
31	532 13 99-76	Bracket Support Fender
37	817 49 05-08	Screw Thdrol 6/16-18 x 1/2 TYT
39	532 17 47-14	Bracket Pivot
38	532 17 57-10	Bracket, Asm. Pivot, Mower Rear
60	872 14 06-06	Bolt RDHD SQNK 3/8-16 UNC x 3/4
64	532 15 47-98	Dash Lower
74	873 68 06-00	Nut Crownlock 3/8-16 UNC
142	532 17 57-02	Plate Reinforcement
143	532 18 66-89	Bracket Swaybar Chassis Notch
144	532 17 55-82	Bracket Footrest
145	532 15 65-24	Rod Pivot Chassis/Hood
206	532 17 01-65	Bolt Shoulder 5/16-18 TT
207	817 67 05-08	Screw Thdrol 5/16-18 x 1/2
208	817 67 06-08	Screw Thdrol 3/8-16 x 1/2
209	817 00 06-12	Screw Hexwsh Thdr 3/8-16 x 3/4
212	532 18 42-48	Insert Lens
258	532 19 05-07	Lens RH Clear
259	532 19 05-08	Lens LH Clear
260	532 40 38-51	Cover Lens
261	532 19 05-05	Insert Grille
278	532 19 16-11	Screw 10 x 3/4 Single Lead-Hex
--	532 00 54-79	Plug Btn

**NOTE:** All component dimensions given in U.S. inches  
1 inch = 25.4 mm





# REPAIR PARTS

**TRACTOR - MODEL NO. MJ15B97 (96011022900), PRODUCT NO. 960 11 02-29  
DRIVE**

KEY NO.	PART NO.	DESCRIPTION	KEY NO.	PART NO.	DESCRIPTION
1	-----	Transaxle, Dana D4360-139 (Order Parts From Transaxle Manufacturer)	63	532 17 54-10	Engine Pulley
2	532 14 66-82	Spring Brake Return	64	532 17 39-37	Bolt Hex
3	532 12 36-66	Pulley Transaxle	65	810 04 07-00	Washer Lock Hvy Hlcl Spr 7/16
4	812 00 00-28	Ring Retainer	66	532 15 47-78	Keeper Belt Engine Foolproof
5	532 12 15-20	Strap Torque 30 Degrees RH	69	532 14 24-32	Screw Hex Wsh Hi-Lo 1/4-1/2 unc
6	817 00 05-12	Screw 5/16-18 x 3/4	70	532 13 46-83	Guide Belt Mower Drive RH
8	532 19 25-02	Rod Shift Fender Adjust STLT	74	532 10 95-02	Spacer Axle
10	876 02 04-16	Pin Cotter 1/8 x 1 Cad	75	532 12 17-49	Washer 25/32 x 1 1/4 x 16 Ga.
11	532 10 57-01	Washer Plate	76	812 00 00-01	E-ring #5133-75
13	874 55 04-12	Bolt 1/4-28 unf Tr. 8 w/Patch	77	532 12 35-83	Key Square 2 0 x 1845/ 1865
14	810 04 04-00	Washer Lock Hvy Helical 1/4	78	532 12 17-48	Washer 25/32 x 1-5/8 x 16 Ga.
15	874 49 05-44	Bolt 5/16-18 Gr. 5	79	532 12 50-96	Key Woodruff #9 3/16 x 3/4
16	873 80 05-00	Nut Lock Hx W/Ins 5/16-18 unc Pl	80	532 13 14-88	Arm Shift
18	874 78 06-16	Bolt Fin Hex 3/8-16 unc x 1 Gr. 5	81	532 16 55-94	Shaft Asm Cross Tapered 18"
19	873 80 06-00	Nut Lock 3/8-16 unc	82	532 16 57-11	Spring Torsion T/a
21	532 10 69-33	Knob	83	819 17 12-16	Washer 17/32 x 3/4 x 16 Ga.
22	532 13 08-04	Rod Brake	84	532 16 62-29	Link Transaxle
24	873 35 06-00	Nut Hex Jam 3/8-16 unc	85	532 15 03-60	Nut Lock Center 1/4-28
25	532 10 68-88	Spring Rod Brake 2 00 Zinc	89	532 40 32-08	Console Shift STLT
26	819 13 13-16	Washer 13/32 x 13/16 x 16 Ga	96	532 12 47-88	Retainer Spring 1"
27	876 02 04-12	Pin Cotter 1/8 x 3/4 Cad	112	819 09 12-10	Washer 9/32 x 3/4 x 10 Ga.
28	532 17 57-65	Rod Brake Parking LT/YT	113	532 12 72-85	Strap Torque 90 Degrees LH
29	532 07 16-73	Cap Brake Parking Black	116	872 14 06-08	Bolt Rdhd Sq Neck 3/8-16 x 1
30	532 17 49-73	Bracket Mtg Transaxle	120	873 90 06-00	Nut Lock Flg. 3/8-16
32	874 76 05-12	Bolt Hex Hd 5/16-18 unc x 3/4	150	532 17 54-56	Spacer Retainer
34	532 17 55-78	Shaft Asm Pedal Foot	151	819 13 32-10	Washer 13/32 x 2 x 10 Ga.
35	532 12 01-83	Bearing Nylon Blk 629 Id	156	532 16 60-02	Washer Srrted 5/16 ID x 1.125
36	819 21 16-16	Washer 21/32 x 1 x 16 Ga	158	532 16 55-89	Bracket Shift Mount
37	532 12 49-63	Pin Roll 3/16 x 1"	159	532 18 39-00	Hub Shift
38	532 17 91-14	Pulley Composite	161	872 14 04-06	Bolt Rdhd Sqnk 1/4-20 x 3/4 Gr. 5
39	872 11 06-22	Bolt Rdhd 3/8-16 x 2-3/4 Gr. 5	162	873 68 04-00	Nut Crownlock 1/4-20 unc
41	532 17 55-56	Keeper Belt Idler Flat	163	874 78 04-16	Bolt Hex Fin 1/4-20 unc x 1 Gr. 5
47	532 12 77-83	Pulley Idler V Groove Plastic	165	532 16 56-23	Bracket Pivot Lever
48	532 15 44-07	Bellcrank Clutch Grnd Drv Stl	166	817 49 05-10	Screw 5/16-18 x 5/8
49	532 12 32-05	Retainer Belt Style Spring	168	532 16 54-92	Bolt Shoulder 5/16-18 x .561
50	872 11 06-12	Bolt Carr. sh 3/8-16 x 1-1/2 Gr. 5	169	532 16 55-80	Plate Fastening STLT/CRD
51	873 68 06-00	Nut Crownlock 3/8-16 unc	170	532 18 74-14	Keeper Belt T/A
52	873 68 05-00	Nut Crownlock 5/16-18 unc	197	532 16 96-13	Nyliner Snap-In 5/8" ID
53	532 19 96-52	Link Clutch	198	532 16 95-93	Washer Nyl 7/8 Id x .105" Hyd
55	532 10 57-09	Spring Return Clutch 6 75	202	872 11 06-14	Bolt 3/8-16 x 1-3/4 Gr. 5
56	817 06 06-20	Screw 3/8-16 x 1-1/4	212	532 14 52-12	Nut Hex Flg Lock
57	532 16 08-55	V-Belt	263	817 00 06-12	Screw 3/8-16 x 3/4
59	532 16 96-91	Keeper Belt Span Ctr	268	532 18 24-02	Guard Muffler
61	817 12 06-14	Screw 3/8-16 x .875	275	819 13 16-14	Washer 13/32 x 1 x 14 Ga.
62	532 12 48-72	Cover Pedal			

**NOTE:** All component dimensions given in U.S. inches  
1 inch = 25.4 mm

# REPAIR PARTS

TRACTOR - MODEL NO. MJ15B97 (96011022900), PRODUCT NO. 960 11 02-29  
STEERING ASSEMBLY

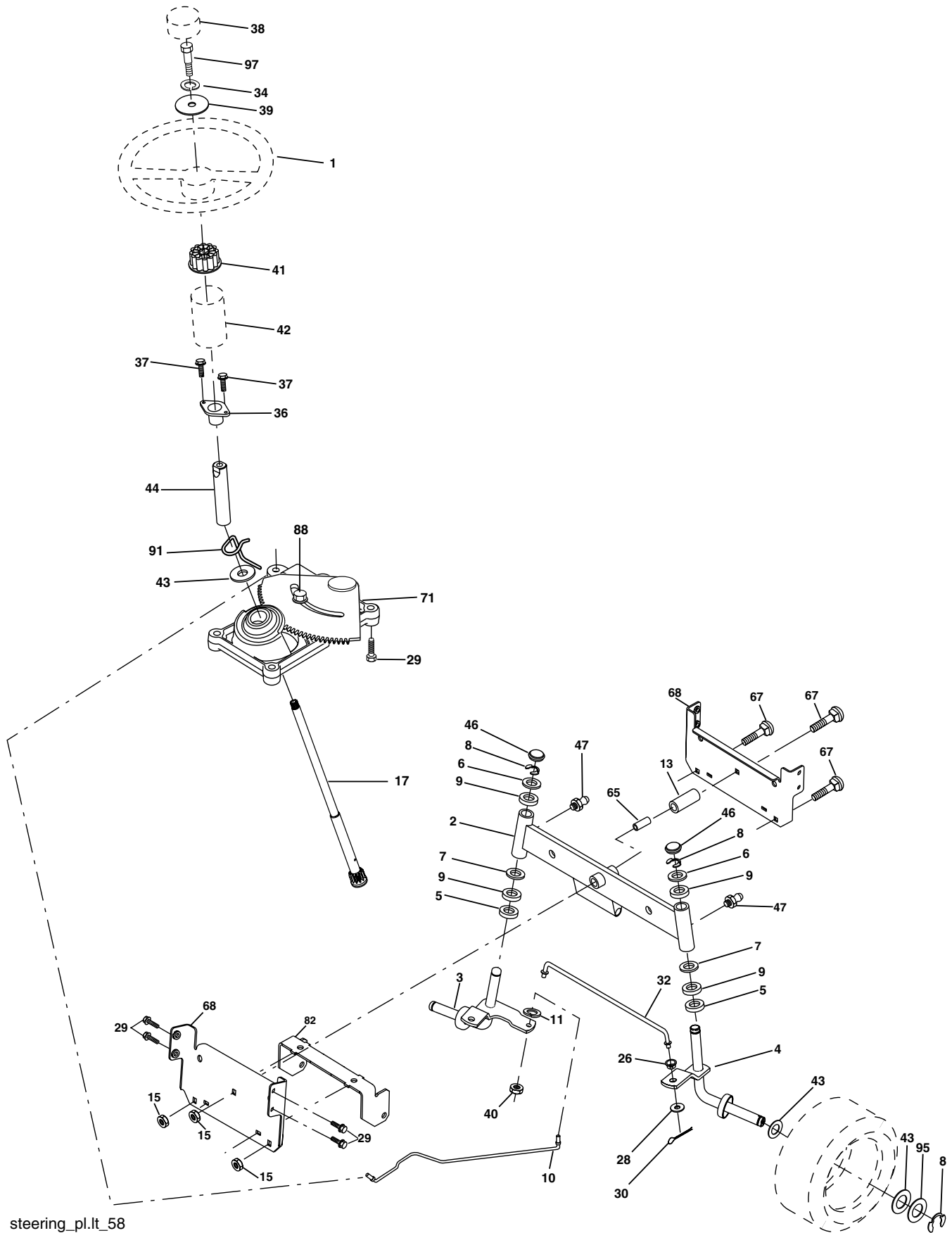

steering\_pl.it\_58

# REPAIR PARTS

## TRACTOR - MODEL NO. MJ15B97 (96011022900), PRODUCT NO. 960 11 02-29 STEERING ASSEMBLY

KEY NO.	PART NO.	DESCRIPTION
1	532 19 45-95	Wheel Steering
2	532 17 51-31	Axle Asm
3	532 16 98-40	Spindle Asm LH
4	532 16 98-39	Spindle Asm RH
5	532 12 49-31	Bearing Race Thrust Harden
6	532 12 17-48	Washer 25/32 x 1-5/8 x 16 Ga.
7	819 27 20-16	Washer 27/32 x 1-1/4 x 16 Ga.
8	812 00 00-29	Ring Klip #t5304-75
9	532 12 49-37	Bearing Col Strg Blk
10	532 17 51-21	Link Drag
11	810 04 06-00	Washer Lock Hvy Hlcl Spr 3/8
13	532 13 65-18	Spacer Brg Axle Front
15	532 14 52-12	Nut Hex Flange Lock
17	532 19 07-53	Shaft Asm Strg
26	532 12 68-47	Bushing Link Drag Blk LR
28	819 13 14-16	Washer 13/32 x 7/8 x 16 Ga.
29	817 00 06-12	Screw 3/8-16 x 3/4
30	876 02 04-12	Pin Cotter 1/8 x 3/4 Cad
32	532 19 27-57	Rod Tie
34	810 04 05-00	Washer Lock Hvy Hlcl Spr. 5/16
36	532 15 50-99	Bushing Strg
37	532 15 29-27	Screw
38	532 19 46-03	Insert Cap Strg Wh
39	819 11 38-12	Washer 11/32 ID x 2-3/8 OD 12 Ga.
40	873 54 06-00	Nut Crownlock 3/8-24
41	532 18 67-37	Adaptor Wheel Strg
42	532 16 96-33	Boot Steering Shaft
43	532 12 17-49	Washer 25/32 x 1-1/4 x 16 Ga.
44	532 19 07-52	Extension Steering Shaft
46	532 12 12-32	Cap Spindle Fr Top Blk
47	532 18 32-26	Fitting Grease
65	532 16 03-67	Spacer Brace Axle
67	872 11 06-18	Bolt, Rdhd Sqnk 3/8-16 x 2-1/4
68	532 16 98-27	Axle, Brace
71	532 17 51-46	Steering Asm.
82	532 19 99-78	Bracket Susp Chassis Front
88	532 17 51-18	Bolt Shoulder 7/16-20
91	532 17 55-53	Clip Steering
95	532 18 89-67	Washer Harden .793 x 1.637 x 060
97	874 78 05-64	Bolt 5/16-18 unc x 4"L Gr. 5

**NOTE:** All component dimensions given in U.S. inches.  
1 inch = 25.4 mm.

# REPAIR PARTS

TRACTOR - MODEL NO. MJ15B97 (96011022900), PRODUCT NO. 960 11 02-29  
SEAT ASSEMBLY

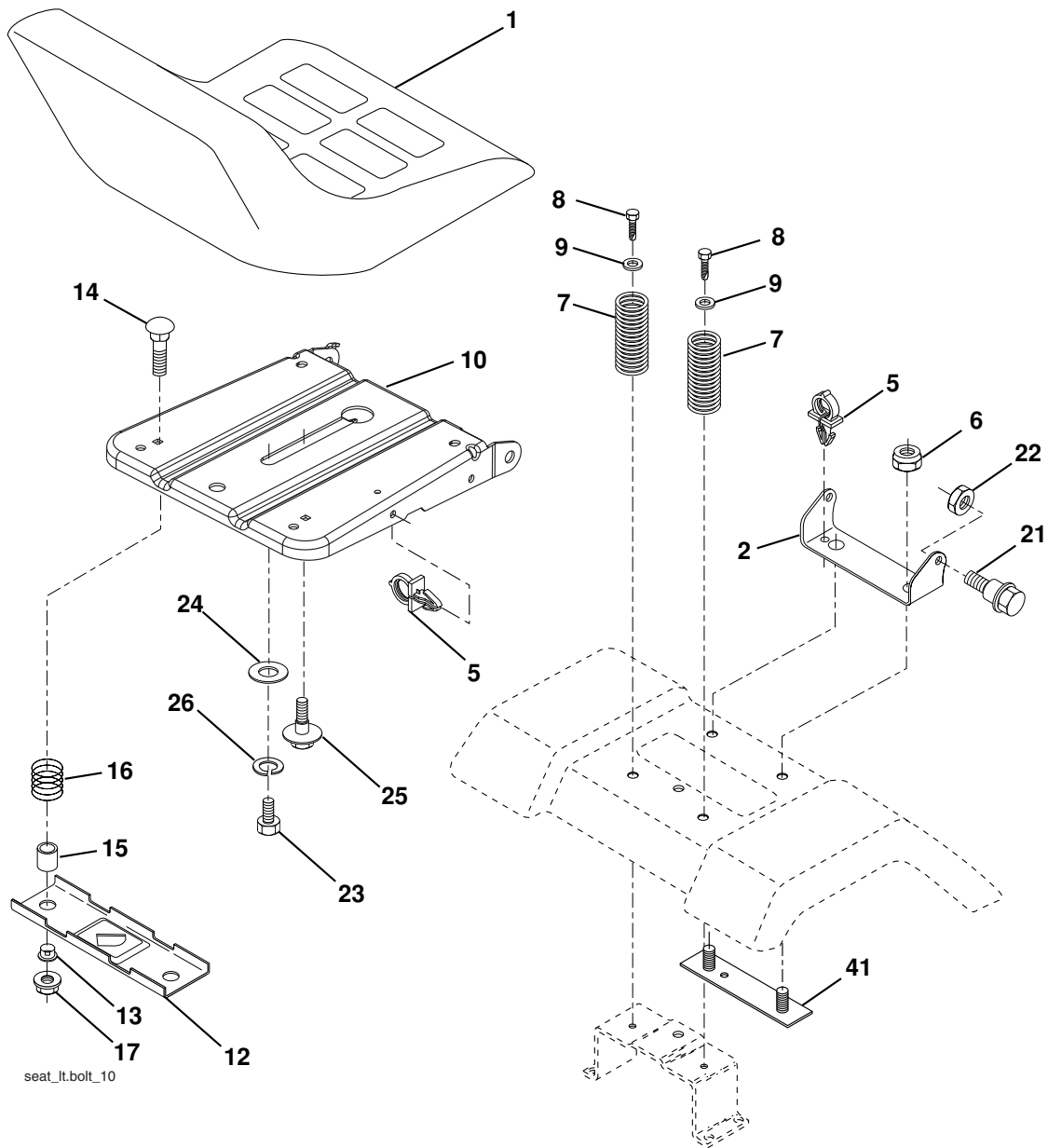

KEY NO.	PART NO.	DESCRIPTION
1	532 40 10-42	Seat
2	532 14 05-51	Bracket Pivot
5	532 14 50-06	Clip Push-In
6	873 80 06-00	Nut Hex w/Ins. 3/8-16 unc
7	532 12 41-81	Spring Seat Cprsn 2 250 Blk Zi
8	817 00 06-16	Screw 3/8-16 x 1-1/2
9	819 13 16-14	Washer 13/32 x 1 x 14 Ga.
10	532 19 55-30	Pan Seat
12	532 17 46-48	Bracket Mounting Switch
13	532 12 12-48	Bushing Snap Blk Nyl 50 Id
14	872 05 04-12	Bolt Rdhd Sqnk 1/4-20 x 1-1/2

KEY NO.	PART NO.	DESCRIPTION
15	532 13 43-00	Spacer Split 28 x 96 Yel Zinc
16	532 12 12-50	Spring Cprsn 1 27 Blk Pnt
17	532 12 39-76	Nut Lock 1/4 Lge Flg Gr. 5 Zinc
21	532 17 18-52	Bolt Shoulder 5/16-18 unc
22	873 80 05-00	Nut Hex Lock W/Ins 5/16-18
23	871 11 08-14	Bolt hex
24	819 17 19-12	Washer 17/32 x 1-3/16 x 12 Ga.
25	532 12 70-18	Bolt Shoulder 5/16-18 x .62
26	810 04 08-00	Washer Lock HVY HLCL SPR 1/2
41	532 14 06-75	Strap Asm.

**NOTE:** All component dimensions given in U.S. inches.  
1 inch = 25.4 mm

# REPAIR PARTS

TRACTOR - MODEL NO. MJ15B97 (96011022900), PRODUCT NO. 960 11 02-29  
ENGINE

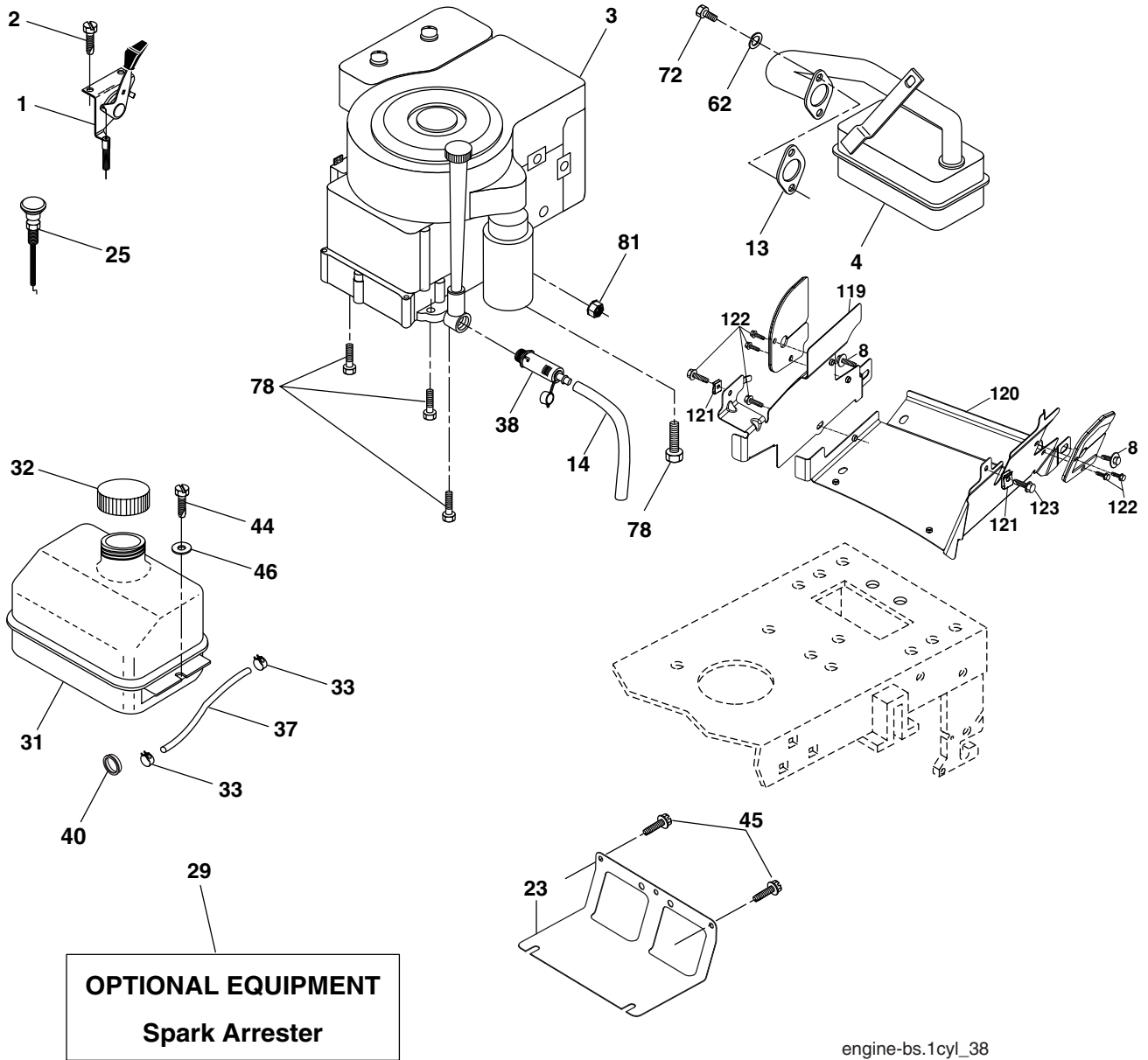

engine-bs.1cyl\_38

KEY NO.	PART NO.	DESCRIPTION	KEY NO.	PART NO.	DESCRIPTION
1	532 17 05-51	Control Th/ch Flag	40	532 12 40-28	Bushing Snap Nyl Blk Fuel Line
2	817 72 04-08	Screw Hex Thd Cut 1/4-20 x 1/2	44	817 67 04-12	Screw Hexwsh Thdrol 1/4-20 x 3/4
3	-----	Engine B&S Model No. 281H07 (Order Parts From Engine Manufacturer)	45	817 00 06-12	Screw Hex Wsh Thdrol 3/8-16 x 3/4
4	532 13 73-52	Muffler LT B&S	46	819 09 14-16	Washer 9/32 x 7/8 x 16 Ga.
8	532 17 18-77	Bolt 5/16-18 UNC x 3/4 w/Sems	62	810 01 05-00	Washer Split
13	532 16 52-91	Gasket Eng 1 313 Id Tin Plated	72	532 19 23-34	Screw socket HD 5/16-18 x .75
14	532 14 84-56	Tube Drain Oil Easy	78	817 06 06-20	Screw 3/8-16x1-1/4
23	532 16 98-37	Shield Brn/Dbr Guard	81	873 51 04-00	Nut 1/4-20
25	532 19 06-95	Control Choke	119	532 40 05-97	Guard Asm Eng LH
29	532 13 71-80	Kit Spark Arrestor (Flat Scrn)	120	532 40 05-96	Guard Asm Eng RH
31	532 18 77-50	Tank Fuel Front	121	532 19 66-88	Clips Threaded
32	532 19 77-25	Cap Asm Fuel	122	532 13 77-29	Screw THD Roll 1/4-20 x 5/8
33	532 12 34-87	Clamp Hose Black	123	817 67 05-08	Screw THDROL 5/16-18 x 1/2
37	532 13 70-40	Line Fuel 20"			
38	532 18 16-54	Plug Drain Oil Easy			

**NOTE:** All component dimensions given in U.S. inches  
1 inch = 25.4 mm

# REPAIR PARTS

TRACTOR - MODEL NO. MJ15B97 (96011022900), PRODUCT NO. 960 11 02-29  
MOWER LIFT

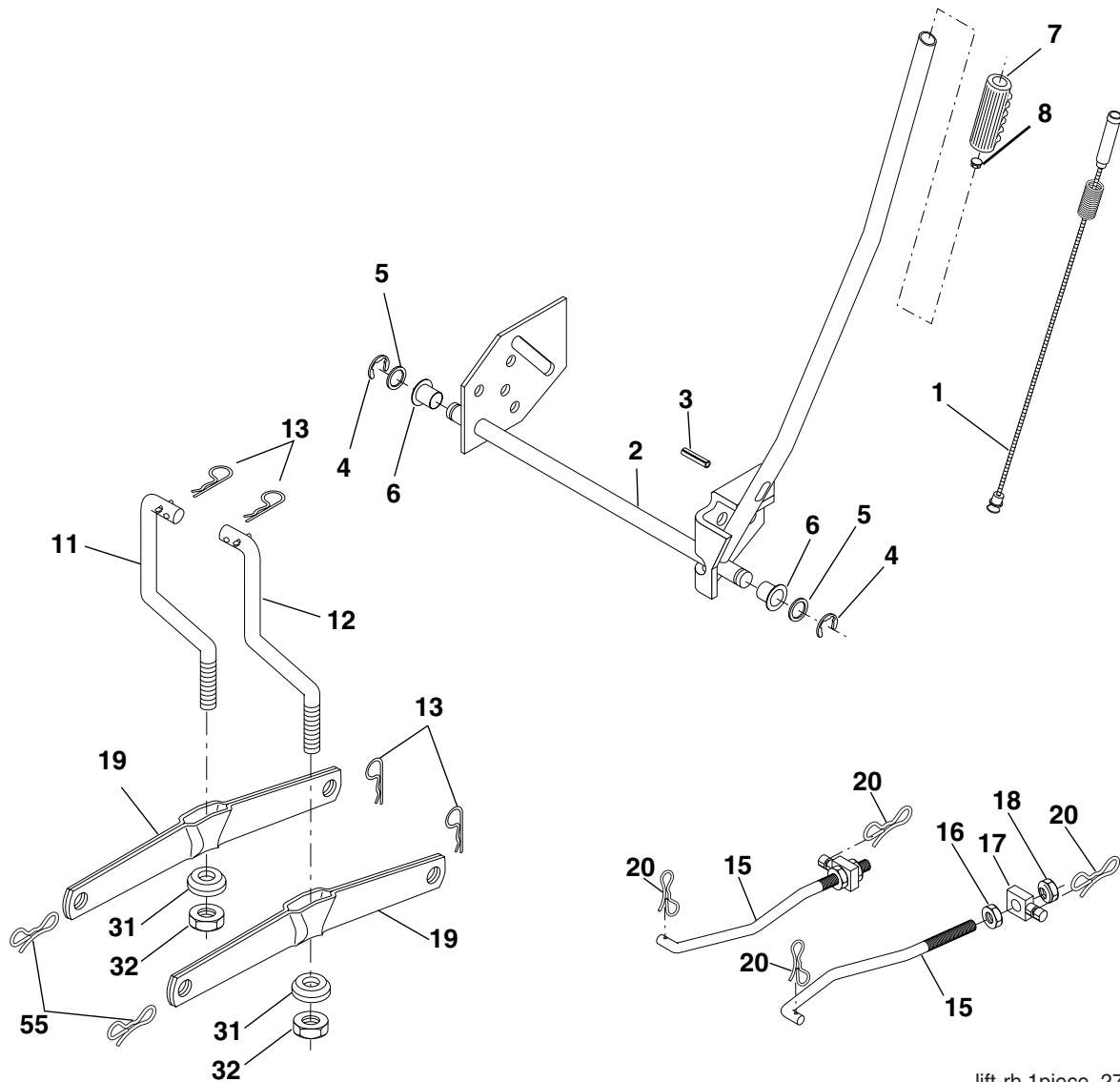

lift-rh.1piece\_27

KEY NO.	PART NO.	DESCRIPTION
1	532 15 94-60	Wire Asm Inner/Spring W/plunger
2	532 15 94-71	Shaft Asm Lift
3	532 10 57-67	Pin Groove
4	812 00 00-02	E Ring #5133-62
5	819 21 16-21	Washer PLTD 21/32 x 1 x 21 Ga.
6	532 12 01-83	Bearing Nylon Blk 629 Id
7	532 10 94-13	Grip Handle
8	532 12 45-26	Button Plunger Black
11	532 13 98-65	Link Lift LH
12	532 13 98-66	Link Lift RH
13	532 12 46-70	Retainer Spring

KEY NO.	PART NO.	DESCRIPTION
15	532 17 32-88	Link Front
16	873 35 08-00	Nut Jam Hex 1/2-13 unc
17	532 17 56-89	Trunnion
18	873 80 08-00	Nut Lock W/wsh 1/2-13 unc
19	532 13 98-68	Arm Suspension Rear
20	532 19 42-09	Spring, Retainer
31	532 16 98-65	Bearing Pvt. Lift
32	873 54 06-00	Nut Crownlock 3/8-24
55	532 19 42-08	Pin Cotter 5/16 Bowtie Lock

**NOTE:** All component dimensions given in U.S. inches  
1 inch = 25.4 mm

# REPAIR PARTS

TRACTOR - MODEL NO. MJ15B97 (96011022900), PRODUCT NO. 960 11 02-29  
DECALS

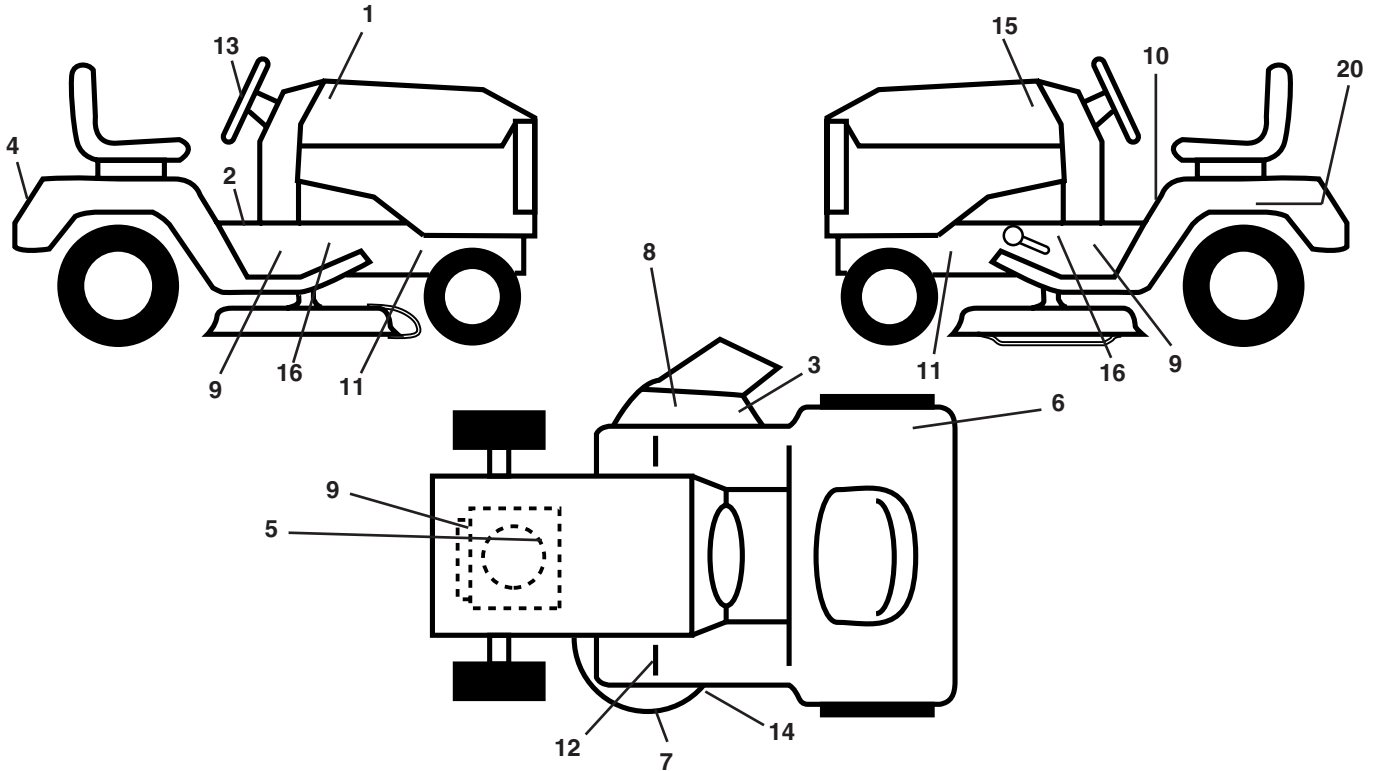

KEY NO.	PART NO.	DESCRIPTION
1	532 40 34-27	Decal Hood RH
2	532 14 08-37	Decal Saddle Brake Parking
3	532 19 63-57	Decal Deflector Warning
4	532 40 22-72	Decal Fender
5	532 19 80-75	Decal HP Engine
6	532 18 04-32	Decal 100DB/CE
7	532 13 49-99	Decal Deck Enviro
8	532 18 21-66	Decal Mower Cutting
9	532 19 68-41	Decal Engine Warning Symbols
10	532 40 03-89	Decal Warning Syms. CE
11	532 15 97-36	Decal Chassis Hot Muffler
12	532 15 97-37	Decal Brake/ Clutch Symbol Lt

KEY NO.	PART NO.	DESCRIPTION
13	532 40 22-73	Decal Steering
14	532 19 43-02	Decal V-Belt Schematic
15	532 40 34-26	Decal Hood LH
16	532 40 11-46	Decal Warning Service/Fire
20	532 14 50-05	Decal Bat Dan/Psn
--	532 16 69-60	Decal Bypass
--	532 16 25-98	Decal Drawbar
--	532 13 83-11	Decal Handle Lift Height Adjust
--	532 18 82-53	Pad Ftrest RH
--	532 18 82-52	Pad Ftrest LH
--	532 40 09-01	Manual Operator's (Euro.)
--	532 40 34-87	Manual Parts

## WHEELS & TIRES

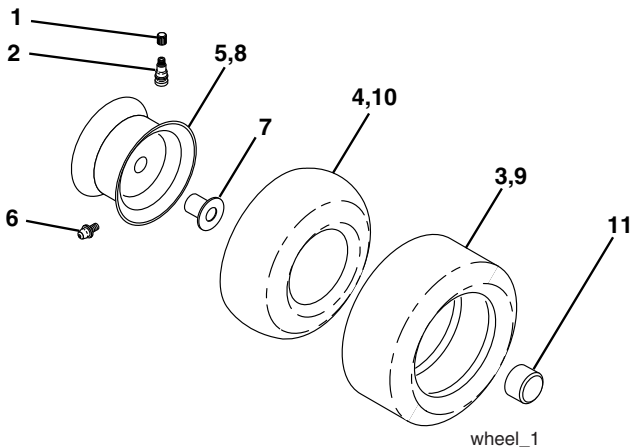

KEY NO.	PART NO.	DESCRIPTION
1	532 05 91-92	Cap Valve Tire
2	532 06 51-39	Stem Valve
3	532 10 62-22	Tire F Ts 15 x 6 0 - 6 Service
4	532 05 99-04	Tube Front (Service Item Only)
5	532 13 83-36	Rim Asm 6" front Service
6	532 12 49-57	Fitting Grease (Front Wheel Only)
7	532 12 49-59	Bearing Flange (Front Wheel Only)
8	532 13 83-37	Rim Asm 8" rear Service
9	532 10 62-68	Tire R Ts 18 x 8 5-8 C Service
10	532 12 49-26	Tube Rear (Service Item Only)
11	532 17 50-39	Cap Axle Blk 1 50 x 1 00
--	532 14 43-34	Sealant, Tire ( 10 oz. Tube)

**NOTE:** All component dimensions given in U.S. inches  
1 inch = 25.4 mm

# REPAIR PARTS

TRACTOR - MODEL NO. MJ15B97 (96011022900), PRODUCT NO. 960 11 02-29  
MOWER DECK

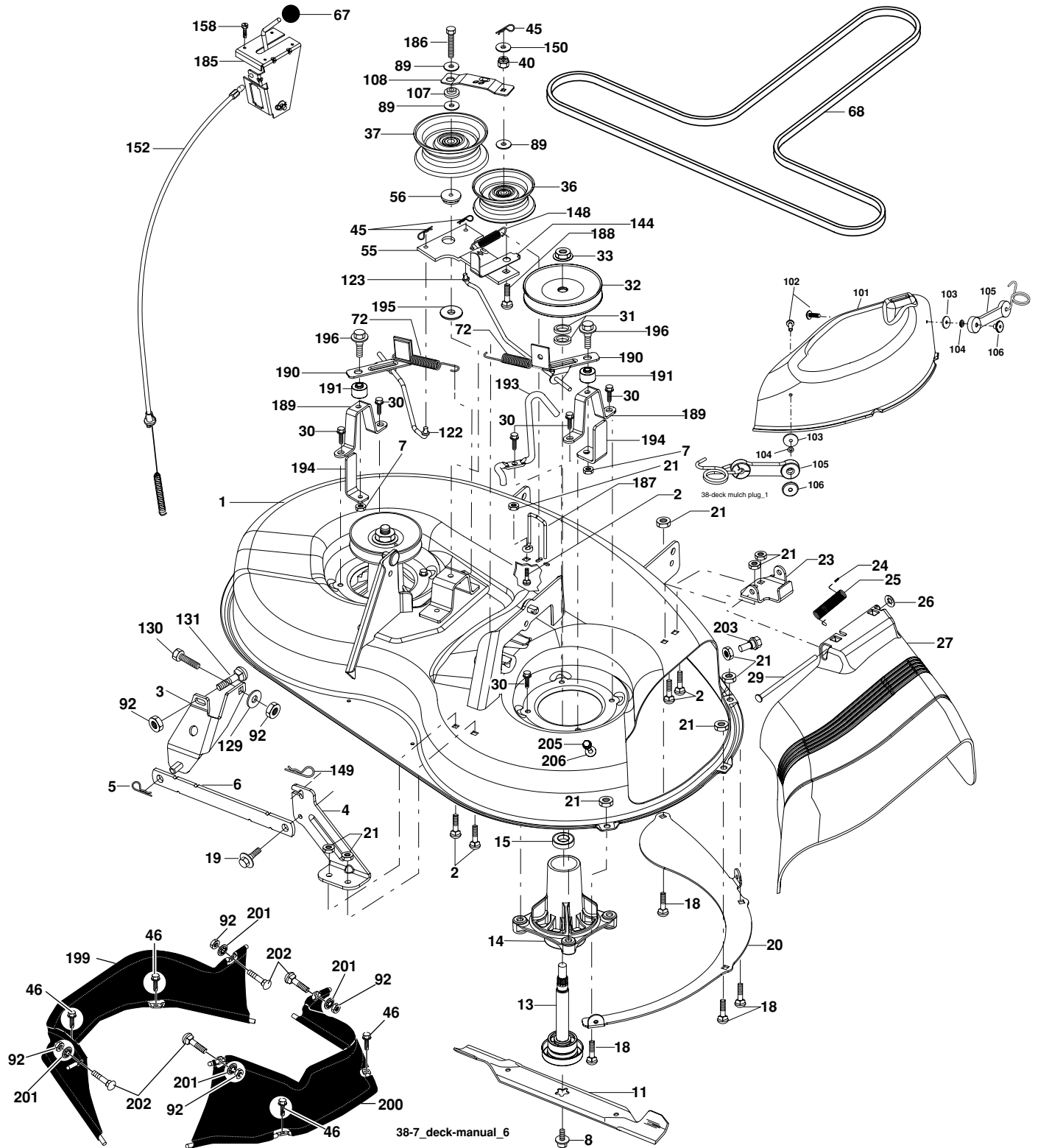

38-42-36 Fabric Guard



# REPAIR PARTS

**TRACTOR - MODEL NO. MJ15B97 (96011022900), PRODUCT NO. 960 11 02-29**  
**MOWER DECK**

KEY NO.	PART NO.	DESCRIPTION	KEY NO.	PART NO.	DESCRIPTION
1	532 19 25-56	Mower Deck Assembly	104	810 07 10-00	Washer Lock #10
2	872 14 05-06	Bolt	105	532 16 07-93	Latch Asm
3	532 13 80-17	Bracket Assembly, Sway Bar	106	532 12 50-04	Nut Weld .327/.304 #10-24
4	532 19 25-68	Bracket Sway Bar	107	532 13 35-02	Spacer, Retainer
5	532 12 46-70	Retainer Spring	108	532 13 35-03	Stiffener, Idler Arm
6	532 17 80-24	Bar, Sway Deck	122	532 19 25-75	Rod, Brake, LH
7	873 80 05-00	Nut Lock Hx W/Insert 5/16-18 unc	123	532 19 25-76	Rod, Brake, RH
8	532 19 30-03	Bolt/Washer Asm. 7/16-20 unf	129	819 13 13-12	Washer 13/32 x 13/16 x 12 Ga.
11	532 19 39-57	Blade, Mower	130	874 78 06-16	Bolt Fin Hex 3/8-16 unc x 1 Gr. 5
13	532 19 28-72	Shaft Assembly, Mandrel	131	872 14 06-08	Bolt RdHd Sqnk 3/8-16 unc x 1
14	532 18 72-81	Housing, Mandrel, Vented	144	532 19 34-14	Keeper Idler Tension
15	532 11 04-85	Bearing, Ball, Mandrel	148	532 16 90-22	Spring Return Idler
18	872 14 05-05	Bolt Rdhd Sqnk 5/16-18 x 5/8	149	532 16 58-98	Retainer Spring Yellow Zinc
19	532 13 28-27	Bolt, Shoulder	150	819 09 12-10	Washer 9/32 x 3/4 x 10 Ga.
20	532 40 00-95	Baffle Vortex Front	152	532 19 32-35	Cable Clutch
21	873 68 05-00	Nut Crownlock 5/16-18	158	817 72 04-08	Screw Hex Thd Cut 1/4-20 x 1/2
23	532 19 25-57	Bracket, Mower Deflector	185	532 18 82-34	Head Asm Cable Clutch
24	532 10 53-04	Cap, Sleeve	186	817 49 06-44	Screw Hxwsh Thdr 3/8-16 x 2-3/4
25	532 19 70-26	Spring, Torsion, Deflector	187	532 19 34-12	Keeper Belt Front
26	532 11 04-52	Nut, Push	188	532 16 58-91	Bolt Carriage Idler
27	532 40 16-18	Shield, Deflector	189	532 19 25-59	Brake Stand 38"
29	532 13 14-91	Rod, Hinge	190	532 19 25-60	Brake Asm.
30	532 17 39-84	Screw Thdrol	191	532 19 25-61	Brake Spacer
31	532 18 76-90	Washer, Spacer	193	532 19 34-13	Keeper Belt RH Mandrel
32	532 15 35-32	Pulley, Mandrel	194	532 19 41-05	Brake Guard
33	532 40 02-34	Nut, Toplock, Flanged	195	819 13 32-10	Washer 13/32 x 2 x 10 Ga.
36	532 13 14-94	Pulley, Idler, Flat	196	532 19 37-82	Bolt/Washer asm 5/16-18
37	532 19 31-98	Pulley Idler Flat	199	532 40 02-80	Guard Asm Fabric LH
40	873 68 06-00	Nut Crownlock 3/8-16	200	532 40 02-81	Guard Asm Fabric RH
45	532 12 47-88	Retainer, Spring	201	532 40 12-20	Push Nut Round 3/8 Diam.
46	532 13 77-29	Screw Thd Roll 1/4-20 x 5/8	202	872 11 06-08	Bolt RDH SQNK 3/8-16 x 1 Gr.5
55	532 13 38-40	Idler Arm Assembly	203	532 19 72-62	Bolt Shoulder
56	532 16 57-23	Spacer, Retainer	205	817 49 04-16	Screw 1/4-20 x 1.00 77
67	532 10 69-32	Knob RD 3/8-16 Plstc Thd	206	819 09 14-16	Washer 9/32 x 7/8 x 16 Ga.
68	532 19 32-14	Belt	--	532 19 25-58	Brake Asm.
72	532 19 32-16	Spring Brake Retainer	--	532 19 28-70	Mandrel Assembly (Includes Housing, Shaft and Shaft Hardware Only - Pulley Not Included)
89	819 13 13-11	Washer 13/32 x 13/16 x 11 Ga.	--	532 19 36-46	Replacement Mower, Complete
92	873 80 06-00	Nut Lock Hex w/Ins. 3/8-16 unc			
101	532 19 25-73	Cover Mulching			
102	871 08 10-10	Screw Pan HD Phillip 10-24 x 5/8			
103	819 06 12-16	Washer #10			

**NOTE:** All component dimensions given in U.S. inches  
1 inch = 25.4 mm

# SERVICE NOTES

---

# SERVICE NOTES

---

