

BAGGER

TRACTOR- -MODEL NO. MBA1392B

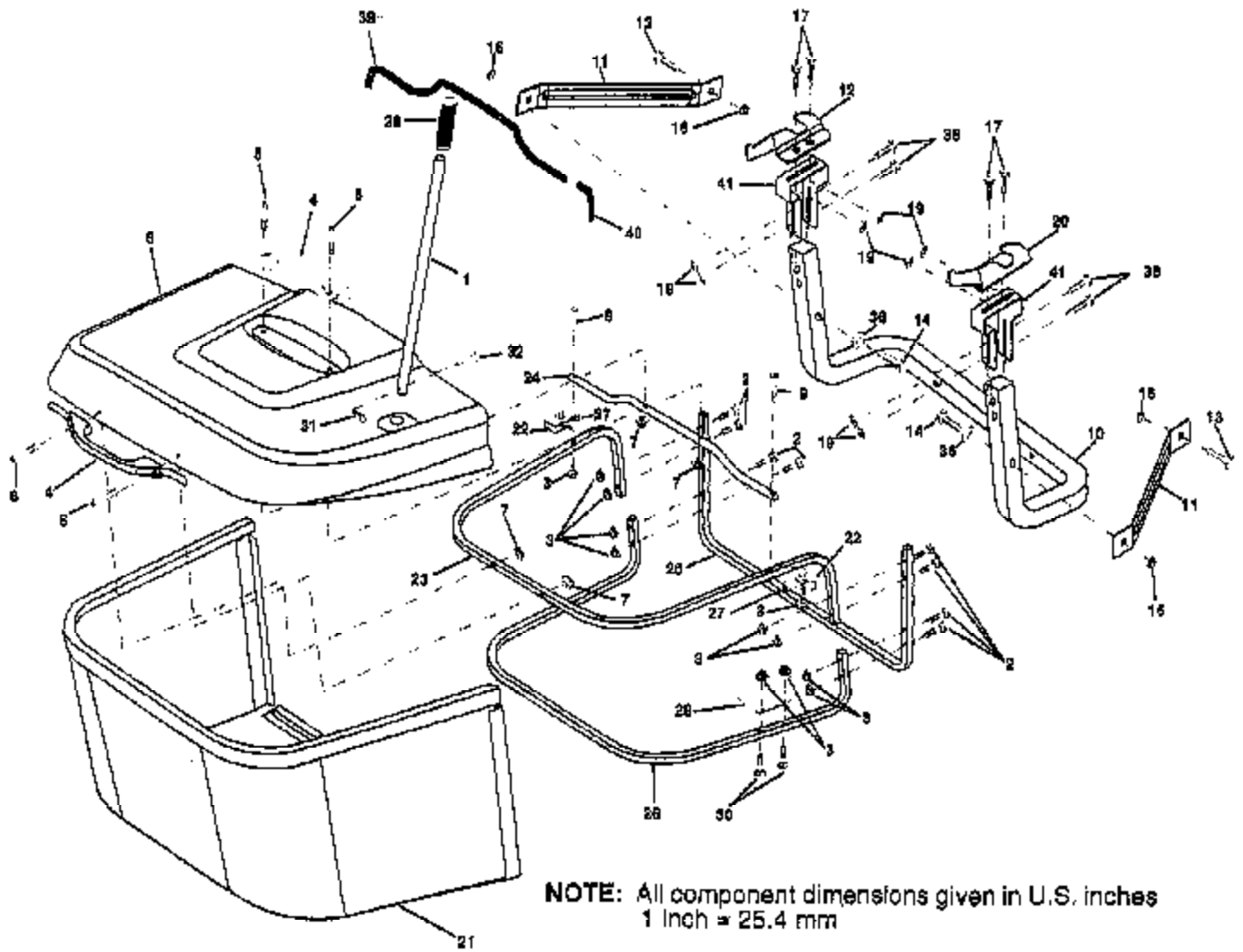

Ref #	Part Number	Qty	Description
1	165249		TUBE.HDLE.BAG.CRD
2	72140416		BOLT.CARRIAGE.1/4-20X2.0
3	123976X		SUB= 73900400
4	169916		HANDLE BAGGER
5	74981024		"SCREW,PAN.HEAD"
6	74981032		SCREW
7	73401000		NUT.WIZ.LOCK
8	165715X558		COVER.BAG.PLASTIC.CRD
9	72140418		BOLT CARRIAGE
10	169688		TUBE SUPPORT BAGGER CRD
11	165719		BRKT.SUPT.UPPER.BAG.CRD
12	169685		BRACKET HORIZ ADJ BGGR LH CRD
13	72110606		BOLT
14	74520640		BOLT.HEX.3/8-16X2-1/2
16	73900600		SUB= 83923
17	72140506		BOLT
19	73800500		NUT
20	169684		BRACKET HORIZ ADJ BGGR RH CRD
21	165780		BAG.ASM.CRD
22	165781		BRKT.SIDE.BAG.CRD
23	165782		TUBE.UPPER.BAG.CRD
24	165783		TUBE.PIVOT.BAG.CRD
25	165784		TUBE.FT.BAG.CRD
26	165785		TUBE.LOWER.BAG.CRD.
27	169692		BUSHING SNAP BAGGER CRD
28	165787		GRIP.HANDLE.BLACK
29	165839		PLATE.STOP.BAG.HDLE.CRD
30	72140410		BOLT.CARRIAGE
31	4497H		RETAINER M
32	126875X		RIVET.DRILL.1.75
36	19132016		SUB= 19132012
38	72010520		BOLT.5/16-18X2.5
39	169999		SEAL
40	170000		SEAL
41	169683		BRACKET VERT ADJ BAGGER CRD

TRACTOR- -MODEL NO. MBA1392B

CHASSIS AND ENCLOSURES

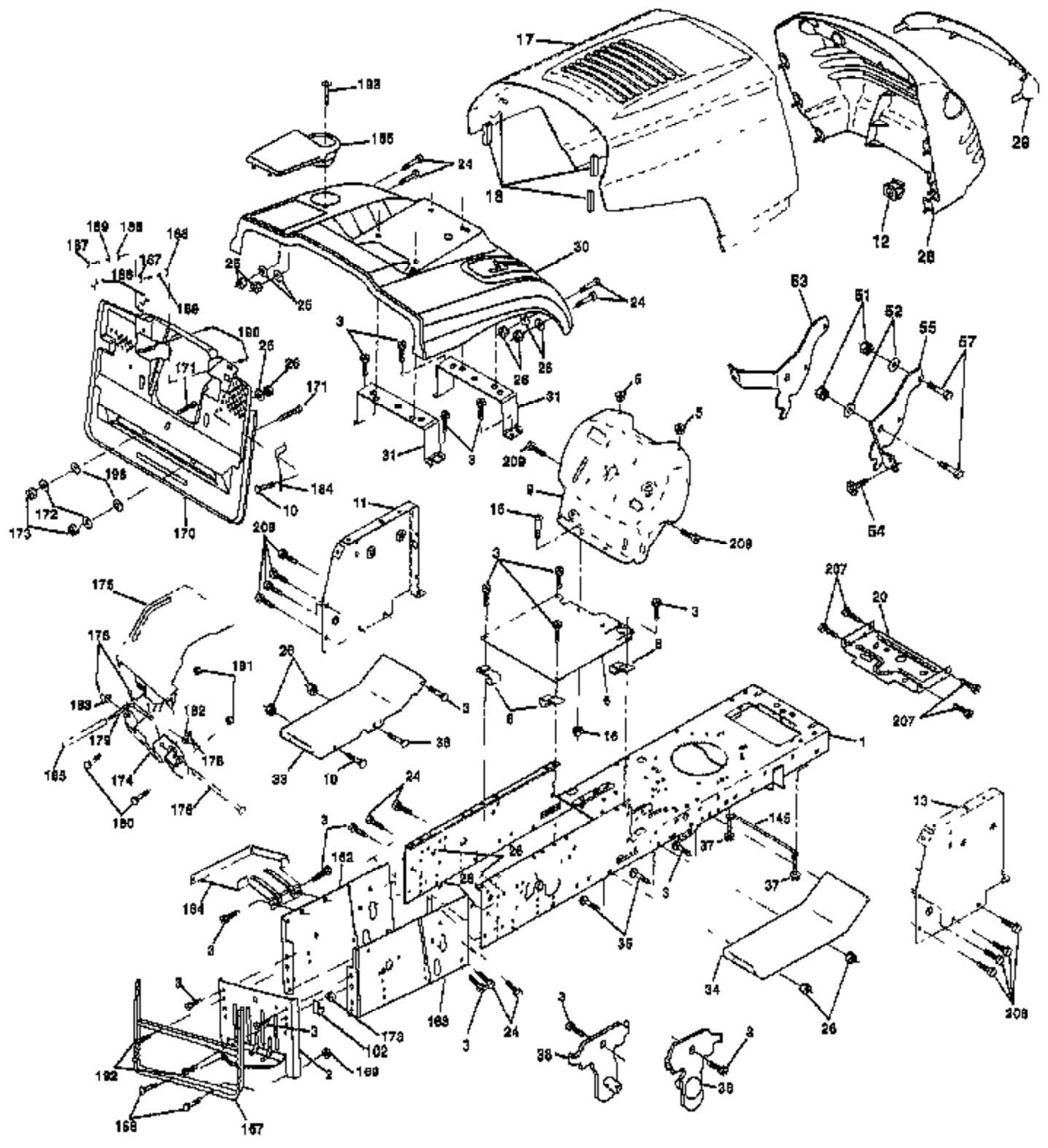

Ref #	Part Number	Qty	Description
1	169831		CHASSIS
2	165606		DRAWBAR.CRD
3	17060612		SCREW
5	155272		BUMPER-HOOD/DASH
6	155923		SADDLE
8	126471X		"CLIP,INSULATOR"
9	168347X011		DASH
10	72140608		SUB= 72110608
11	155927		"PANEL-DASH,LH"
12	145660		CLIP.TINNERMAN
13	172107X010		DASHBOARD
15	74180512		SCREW
16	73510500		NUT
17	159639X558		HOOD.PNT.W/TRIM
18	126938X		SUB= 532126938
20	156437		"PLATE-MTG,BATT/FU"
24	74780616		BOLT
25	19131312		WASHER
26	73800600		NUT
28	157539		GRILLE
29	150209X599		LENS.GRILLE
30	165714X558		FENDER
31	165156		BRKT.SUPT.FENDER.CRD
33	145244X558		FOOTREST.LH.YT/GT
34	145243X558		FOOTREST.RH.LT/YT
35	72110606		BOLT
37	17490508		SCREW LT
38	169834		BRKT ASM PIVOT MOWER REAR
51	73800400		NUT
52	19091416		WASHER
53	144697		BRACKET.GRILLE.LH
54	161464		SCREW.HEX.WS.HD
55	144696		BRACKET.GRILLE.RH
57	74780412		SUB= 74780414
102	2751R		CLIP T
145	156524		"ROD POVOT,CHASSIS"
162	165672		BRKT.EXT.CHASSIS.LH.CRD
163	165673		BRKT.EXT.CHASSIS.RH.CRD
164	165605		SUPPORT.BATTERY.CRD
165	165742X428		COVER.BATTERY.CRD.BLACK.LT
167	165779		SUPT.ASM.BACKPLATE
168	72050412		BOLT-RD HD SQ NK
169	123976X		SUB= 73900400
170	165607		COVER.BACKPLATE.BLACK
171	74520640		BOLT.HEX.3/8-16X2-1/2
172	19132016		SUB= 19132012
173	73510600		NUT
174	165939		BRKT.SWITCH.FBI.CRD
175	166212		GRUARD.DOOR.REAR.CRD
176	128600		HINGE PIN
177	132796		SPRING.COVER.LH
178	76020312		SUB= 3145
179	165942		ROD.PIVOT.FBI.CRD
180	74760516		SUB= 77394
181	73680500		SUB= 73690500
182	138200		WASHER.385X.625
183	19131316		WASHER
184	166139		BRKT.ACTUATOR.BAG.CRD

Ref #	Part Number	Qty	Description
185	165940		TUBE.LEVER.SWCH.FBI.CRD
186	160793		LATCH ASSY.BAGGER
187	2029J		WELDNUT
188	19061216		WASHER #10
189	10071000		LOCKWASHER
190	71161010		SCREW
192	17490624		SCREW LT
193	17070412		SCREW
198	168937		NUT PUSH
207	17670508		SCREW
208	17670608		SCREW
209	17000612		SCREW
	5479J		PLUG BUTTON T

TRACTOR- -MODEL NO. MBA1392B

DECALS

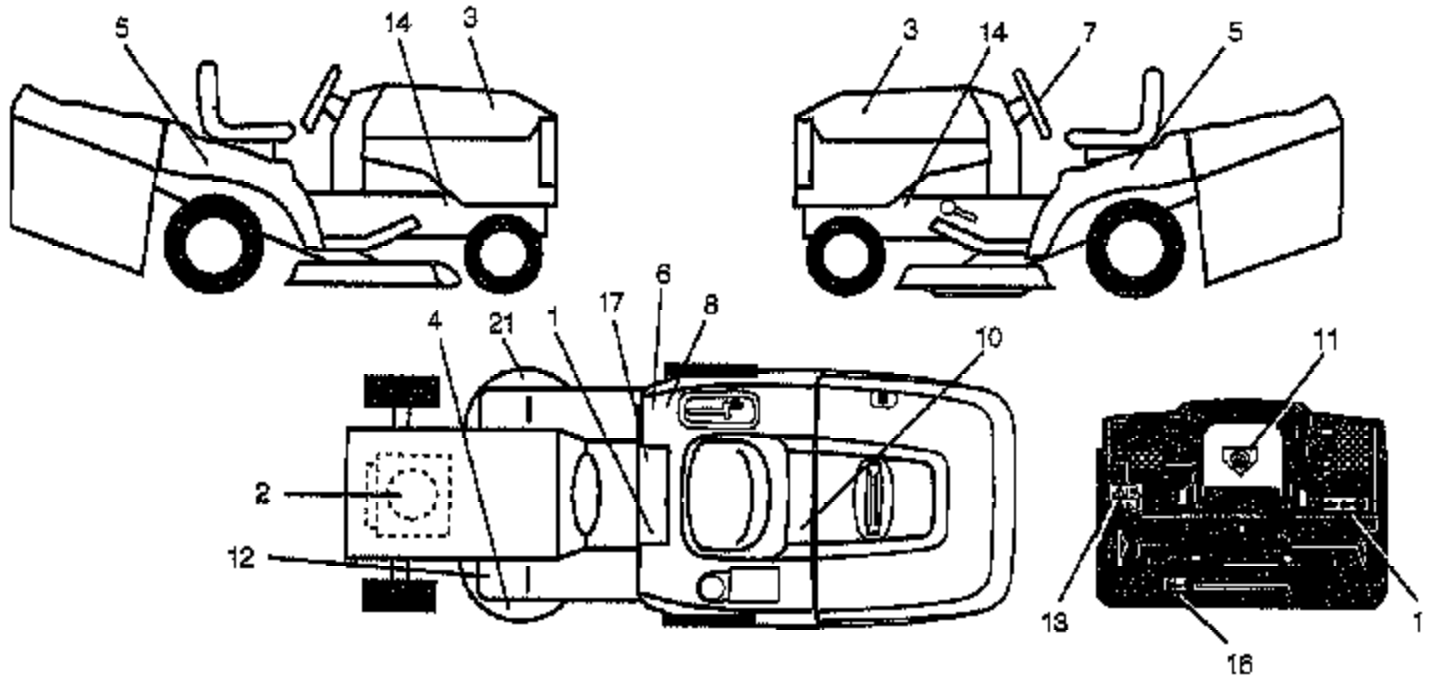

Ref #	Part Number	Qty	Description
1	145498		DECAL.READ.O.MANU
2	64-1726-29		DECAL HP ENGINE
3	171668		DECAL HOOD LOGO
4	134999		"DECAL,ENVIRO DECK"
5	167719		DECAL.FEND.13/92.6SP
6	126187X		SUB= 532126187
7	167970		DECAL.WHL.STEERING
8	145437		DECAL.EURO.ST.CE.
10	145005		DECAL.BATRY.3-3908
11	145494		DECAL.DANGER.CUTF
12	159737		DECAL-BRAKE/CLUTC
13	166959		DECAL.WARNING.BACKPLATE.CRD
14	159736		"DECAL CHASSIS,HOT"
15	166961		DECAL, OPER BAG
16	162598		DECAL.DRAWBAR.LDL
17	140837		DECAL BRAK PARK
21	166286		DECAL.DECK.HEX.BELT
	138311		DECAL HANDLE LIFT
	157199X428		PAD.FOOTREST.SQ.GENERIC
	171955		MANUAL OPERATOR'S
	171956		MANUAL PARTS

TRACTOR- -MODEL NO. MBA1392B

DRIVE

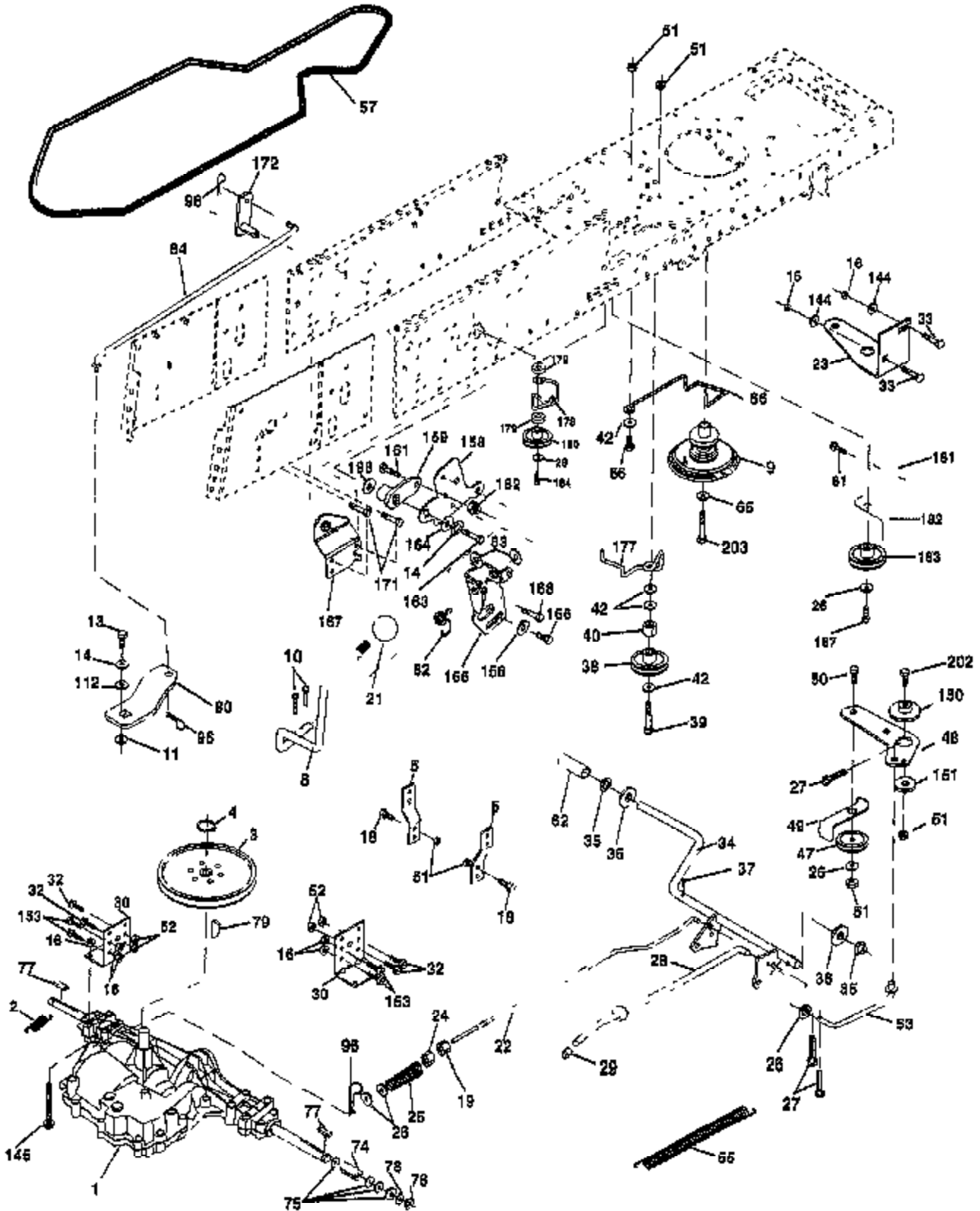

Ref #	Part Number	Qty	Description
1	SUPPLIER		CHECK WITH SUPPLIER
2	146682		SPRING.BRAKE.RETU
3	165999		"PULLEY.TRANSAXLE.7""
4	12000028		SUB= 2267J
5	121520X		STRAP TORQUE
8	165619		ROD.SHIFT.FENDER.ADJ.LT.CRD
9	170163		CLUTCH ASM NORAM
10	76020416		PIN COTTER 1/8
11	105701X		WASH-SHFT PLT LT
13	74550412		BOLT.1/4-28.W/PAT
14	10040400		LOCKWASHER
16	73800500		NUT
18	74780616		BOLT
19	73800600		NUT
21	106933X		KNOB T (1/2-HOLE)
22	165811		ROD.BRAKE.PMST.CRD
23	170017		BRACKET CLUTCH
24	73350600		NUT
25	106888X		SPRING ROD LT
26	19131316		WASHER
27	76020412		COTTER PIN
28	145204		ROD.BRAKE.PARK.LT
29	71673		PLUNGER CAP T
30	130807		TRANSAXLE MTG BKT
32	74760512		BOLT
33	72140506		BOLT
34	165496		SHAFT.ASM.PEDAL.FOOT.CRD
35	120183X		NYLON BEARING
36	19211616		WASHER LT
37	1572H		SUB= 2882J
38	165936		PULLEY.FLAT
39	72110622		BOLT
40	4470J		SPACER T
42	19131312		WASHER
47	127783		SUB= 139245
48	154407		BELLCRANK.CLUTCH
49	123205X		RETAIN BELT
50	74760624		SUB= 74930624
51	73680600		SUB= 73690600
52	73680500		SUB= 73690500
53	105710X		"LINK, CLUTCH T"
55	105709X		"SPRING, RETURN LT"
56	74760620		SUB= 74780620
57	165631		"V-BELT.KEV.111""
61	17060612		SCREW
62	8883R		PEDAL COVER T
65	10040700		LOCKWASHER
66	154778		KEEPER-BELT
74	137057		SPACER AXLE
75	121749X		WASHER
76	12000001		E-RING LT
77	123583X		SQUARE KEY
78	121748X		WASHER
79	2228M		SUB= 2228M1
80	145090		"ARM.SHIFT.20""TIRE"
82	123782X		"SPRING,TORSION"
83	19171216		WASHER
84	165621		LINK.SHIFT.CRD

Ref #	Part Number	Qty	Description
96	4497H		RETAINER M
112	19091210		WASHER LT
144	19111016		WASHER
145	74490540		BOLT.HEX.FLGHD
150	165850		BUSHING.BELLCRANK.GRD.DR
151	19133210		WASHER
153	74760516		SUB= 77394
156	166002		WASHER.SRRTD.5/16
158	165589		BRKT.SHIFT.MOUNT
159	165494		HUB.SHIFT
161	72140406		BOLT T
162	73680400		SUB= 73690400
163	74780416		NLA
164	19091010		WASHER.5/8X.281X10GA
165	165623		BRKT.PIVOT.LEVER
166	166880		SCREW.5/16-18X5/8
167	165588		BRKT.SUPT.SHIFT.CRD
168	165492		BOLT.SHOULDER.5/16-18X.561
171	17490608		SCREW LT
172	165635		SHAFT.ASM.SHIFT.FRT.CRD
177	165932		KEEPOER.FLAT.IDLER
178	165933		KEEPER.BELT.IDLER
179	120958X		WASHER
180	165630		PULLEY.FLAT.IDLER
181	165797		BRKT.IDLER.GRD.DR.CRD
182	165634		"KEEPER.BELT.2.5"".OD.CRD"
183	165626		PULLEY.V-IDLER
184	17490644		SCREW.HXWSH.3/8
187	17490620		SCREW
198	169593		WASHER NYLINER
202	72110612		BOLT.3/8-16X1.50
203	71170780		BOLT HEX

TRACTOR - MODEL NO. MBA1392B

ELECTRICAL

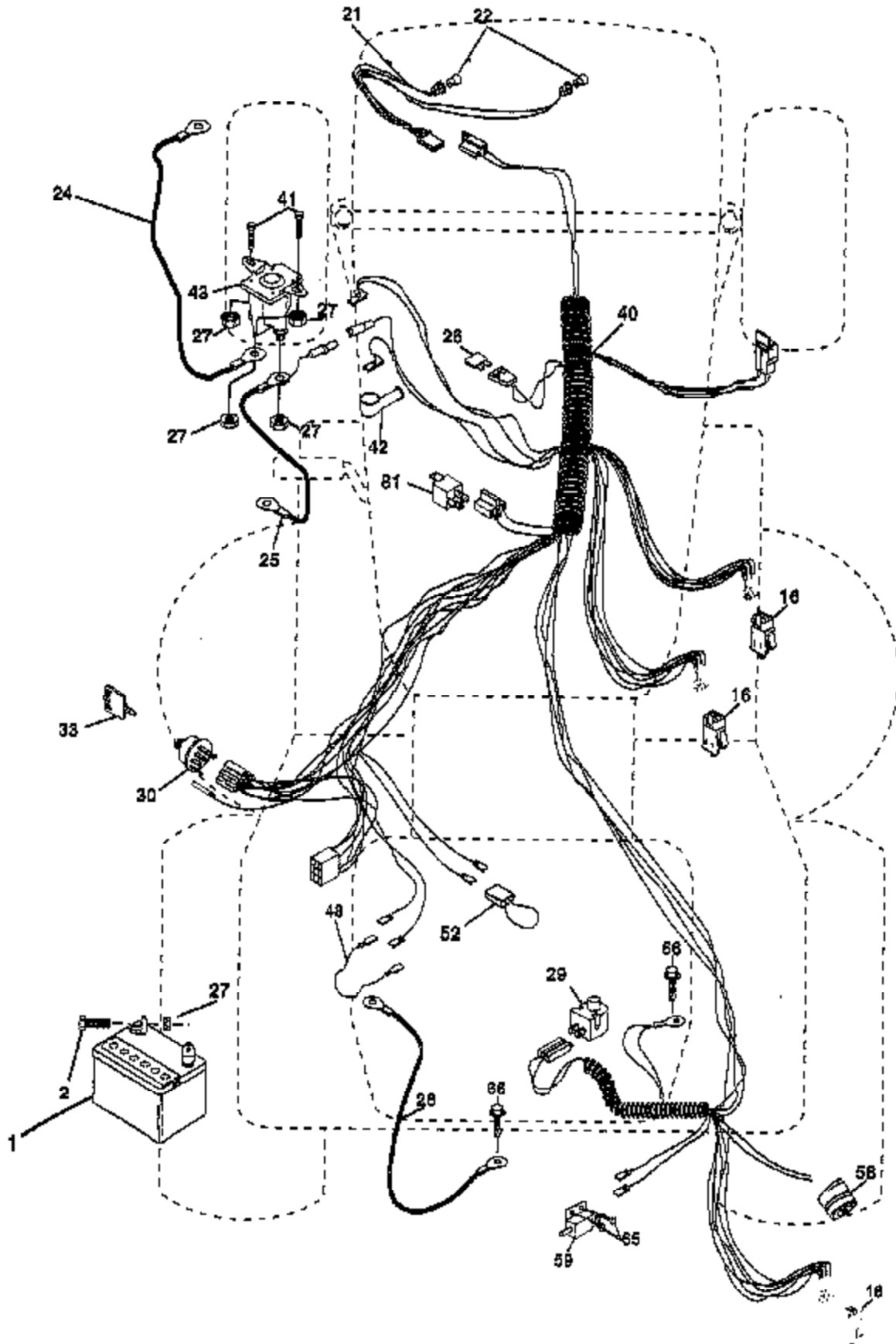

Ref #	Part Number	Qty	Description
1	144925		SUB= 123899X
2	74760412		BOLT LT
16	153664		SWITCH INTERLOCK
21	166181		HARNES.ASM.LIGHT W/4152J
22	4152J		HEADLAMP BULB
24	108423X		CABLE ASM.
25	165987		CABLE.BATTERY.CRD
26	166180		FUSE.15 AMP
27	73510400		NUT
28	127725X		"CABLE.GRD.6GA/18""BLACK"
29	160784		SWITCH.PLUNGER
30	163968		SWITCH.IGN.
33	140401		KEY MLD GEN DELTA
40	170164		HARNES IGN CORD
41	71110408		BOLT HXHD FIN
42	131563		SUB= 154336
43	145673		SUB= 146154
48	140844		ADAPTER AMMETER
52	141940		PROTECTION LOOP
58	169419		BUZZER CRD
59	166299		SWITCH.FBI.CRD
65	17211008		SCREW
66	17490608		SCREW LT
81	109748X		RELAY ASSY T

TRACTOR- -MODEL NO. MBA1392B

ENGINE

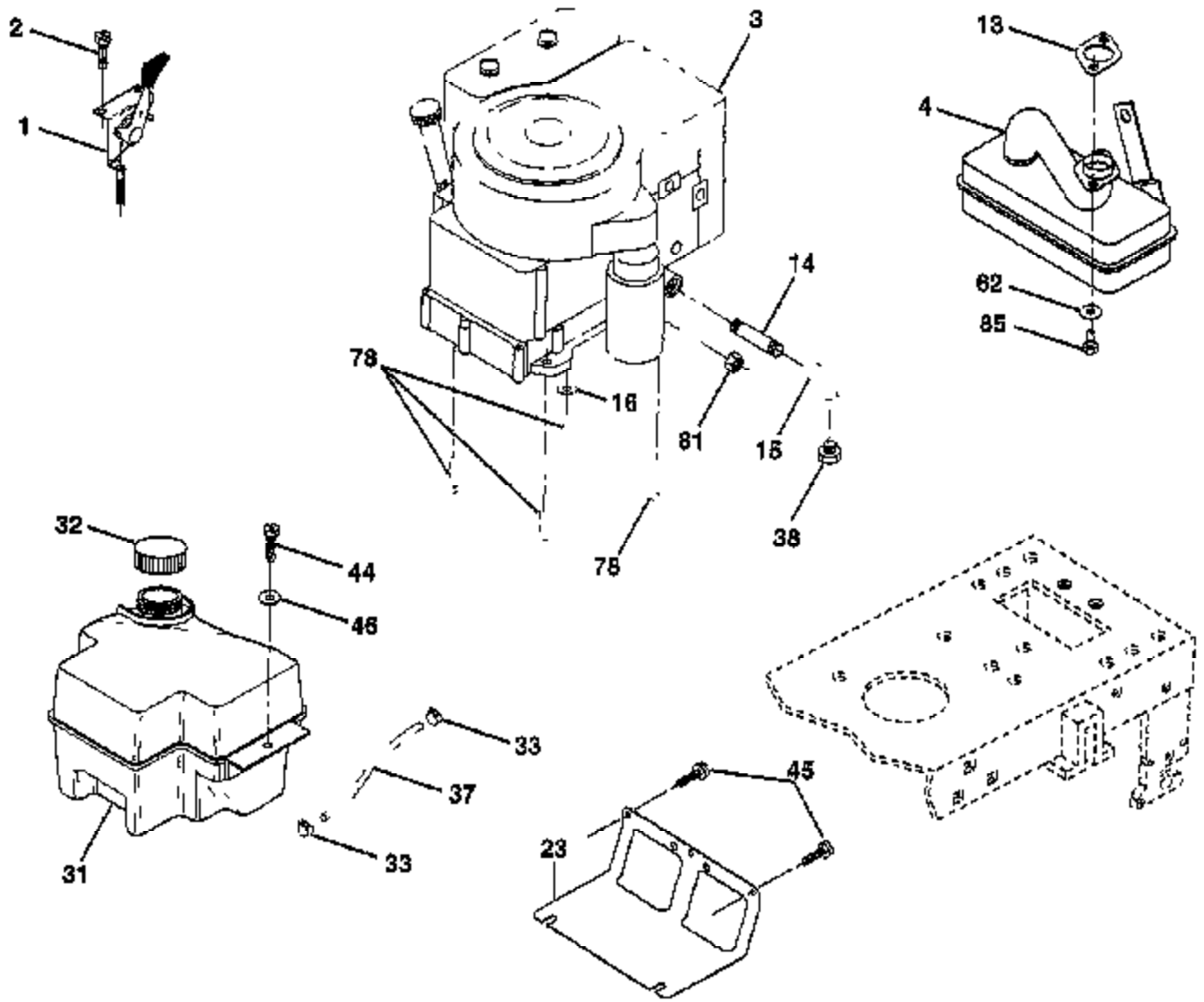

29

OPTIONAL EQUIPMENT
Spark Arrester

Ref #	Part Number	Qty	Description
1	157626		CONTROL-THROT/CHO
2	17720410		SCREW LT
3	SUPPLIER		CHECK WITH SUPPLIER
4	156700		MUFFLER TEC. 13HP
13	165291		SUB= 272293
14	13280336		PIPE NIPPLE LT
15	13200300		ELBOW
16	11050600		LOCKWASHER
23	169837		SHIELD BROWNING
29	137180		SUB= 532137180
31	161911		TANK.FUEL.FRONT.
32	140527		CAP ASM FUEL
33	123487X		HOSE CLAMP
37	137040		LINE FUEL
38	SUPPLIER		CHECK WITH SUPPLIER
44	17490412		SCREW HEX CRT
45	17000612		SCREW
46	19091416		WASHER
62	10040500		LOCKWASHER
78	17060620		SCREW
81	73510400		NUT
85	123528X		SCREW HEX HD CAP

Ref #	Part Number	Qty	Description
1	165552		HOUSING.ASM.MOWER
2	72140506		BOLT
3	165569		BRKT.ASM.S-BAR.CHASSIS
4	165558		BRKT.BAR.SWAY.DECK
5	4939M		SUB= 85902
6	165557		BAR.SWAY.92.CRD
8	850857		BLADE BOLT
9	10030600		SUB= 10040600
10	140296		WASHER.HARD.BLADE
11	165560		BLADE.3-1.LH.92.CRD
12	129895		BEARING.BALL
13	137645		SUB= 137646
14	128774		HSG ASM MANDREL
15	110485X		BEARING
16	170038		BLADE
17	72140610		BOLT.3/8-14X1.25
18	72110608		BOLT D
19	132827		BOLT SHD 5/16-18
20	165484		BOLT.3/8-24X1.25
21	73680500		SUB= 73690500
22	165243		BRKT.IDLER.SPRT.CRD
23	165446		"BRKT.IDLER.SPRT.RF.92,CRD"
24	165242		BRKT.SUSP.LF.92.CRD
25	165244		BRKT.SUSP.RF.92.CRD
26	165237		BRACE.SUPT.SUSP.FRT.CRD
27	165568		BRKT.ASM.SUSP.RR.92.CRD
28	165567		BRKT.ASM.SUSP.LR.92.CRD
30	157722		"SCREW-THD ROLL,WA"
31	129963		WASHER
32	153531		PULLEY.MAND.36/46
33	137266		SUB= 139729
34	165239		BRKT.GUAGE.WHL.LF.92.CRD
35	165238		BRKT.GUAGE.WHL.RF.92.CRD
36	146763		PULLEY.IDLER.4.25
37	19131316		WASHER
40	73680600		SUB= 73690600
44	165724		COVER.MANDREL.LH.92.CRD
45	165556		COVER.MANDREL.RH.92.CRD
46	137729		SCREW.1/4-20X5/8
55	165445		ARM.IDLER.92.CRD
56	165723		SPACER.RETAINER.MOWER
61	165945		SPRING.TENSION.BELT
67	106932X		KNOB T(3/8 HOLE)
68	165555		HEX-BELT.92.MWR.105AA
69	165482		SHAFT.ASM.W/LWR.BRG.RH.THD
84	156085		"KEEPER-BELT,IDLER"
116	137644		BOLT.SHOULDER
117	133957		WHEEL GAGE DONUT
118	73930600		LOCKNUT
119	19121414		WASHER
124	72110612		BOLT.3/8-16X1.50
128	153390		WASHER.FELT.
130	72110506		SUB= 72270506
131	165661		CHUTE.BAGGER.CRD
151	169670		BRKT CLUTCH CABLE
152	170300		CABLE CLUTCH CRD SERVICE
153	169674		WASHER FLAT
154	169675		SPRING RETAINER

Ref #	Part Number	Qty	Description
155	169671		SPRING RETENTION LVR CLUTCH CAB
156	169672		SPACER
157	169669		ROD.CLUTCH.CABLE.3/8
158	17720410		SCREW LT
	130794		MANDREL ASM
	165579		MANDREL.ASM.CRD.LH.THREADS
	165578		DECK.MOWER.COMPLETE

TRACTOR- -MODEL NO. MBA1392B

MOWER LIFT

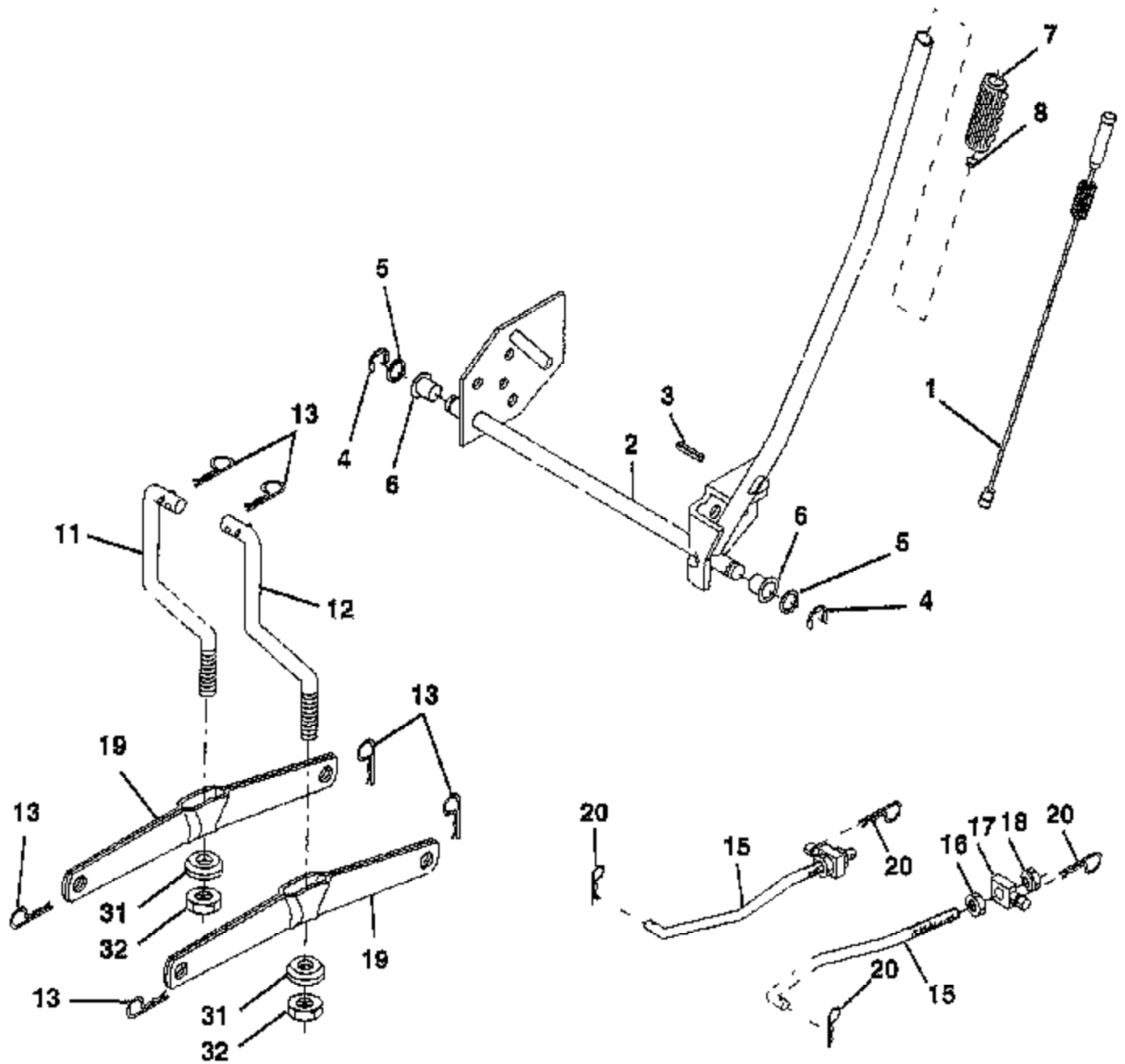

NOTE: All component dimensions given in U S inches
1 inch = 25.4 mm

Ref #	Part Number	Qty	Description
1	159460		WIRE ASM W.SPRING
2	159471		"SHAFT ASM LIFT,RH"
3	105767X		PIN-GROOVE LT
4	12000002		SUB= 2225J
5	19211621		WASHER
6	120183X		NYLON BEARING
7	109413X		GRIP
8	124526X		SUB= 125925X
11	165829		LINK.LIFT.LH.CRD
12	165831		LINK.LIFT.RH.CRD
13	4939M		SUB= 85902
15	167253		LINK, FRONT
16	73350800		NUT
17	130171		TRUNION
18	73800800		NUT.LK.W/WSH.1/2.
19	139868		ARM SUSP REAR
20	163552		RETAINER SPRING
31	140302		BEARING PVT LH
32	73540600		NUT.CROWNLOCK.3/8

TRACTOR- -MODEL NO. MBA1392B

SCHEMATIC

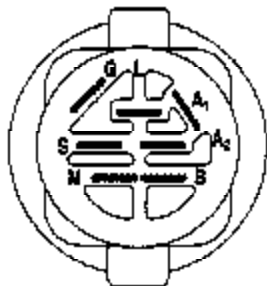
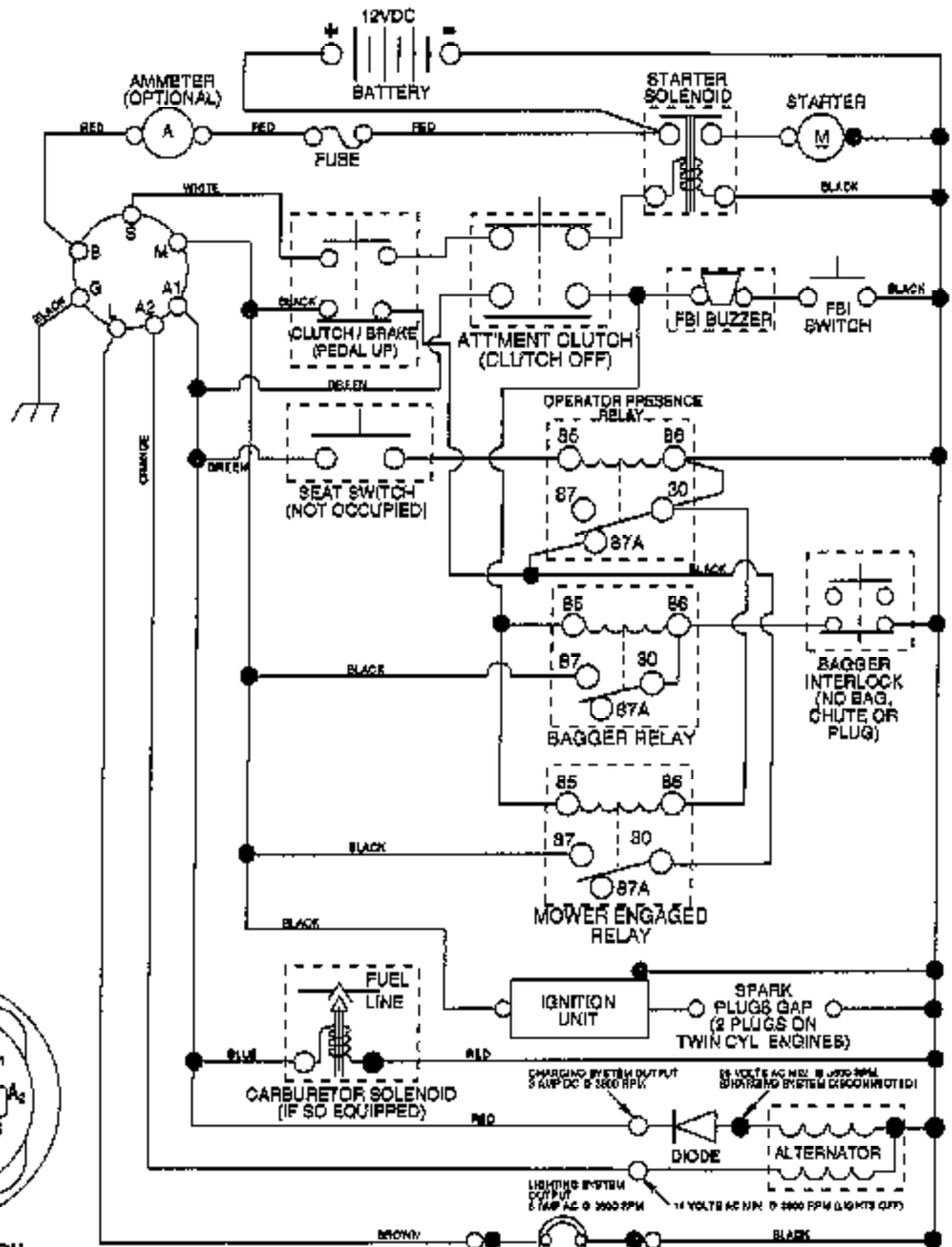

IGNITION SWITCH

POSITION	CIRCUIT	"MAKE"
OFF	M+G+A1	NONE
RUN/LIGHT	B+A1	A2+L
RUN	B+A1	NONE
START	B+S+A1	NONE

WIRING INSULATED CLIPS
NOTE IF WIRING INSULATED CLIPS WERE REMOVED FOR SERVICING OF UNIT THEY SHOULD BE REPLACED TO PROPERLY SECURE YOUR WIRING

NON-REMOVABLE CONNECTIONS

REMOVABLE CONNECTIONS

PTO SWITCH

POSITION	CIRCUIT
OFF	C+G B+H
ON	C+F B+E A+D

HEADLIGHTS

NOTE
YOUR TRACTOR IS EQUIPPED WITH A SPECIAL ALTERNATOR SYSTEM. THE LIGHTS ARE NOT CONNECTED TO THE BATTERY BUT HAVE THEIR OWN ELECTRICAL SOURCE. BECAUSE OF THIS THE BRIGHTNESS OF THE LIGHTS WILL CHANGE WITH ENGINE SPEED. AT IDLE THE LIGHTS WILL DIM AS THE ENGINE IS SPEEDED UP THE LIGHTS WILL BECOME THEIR BRIGHTEST.

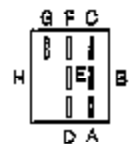
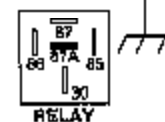

Ref #	Part Number	Qty	Description
	REFER		REFER TO IMAGE

TRACTOR- -MODEL NO. MBA1392B

SEAT ASSEMBLY

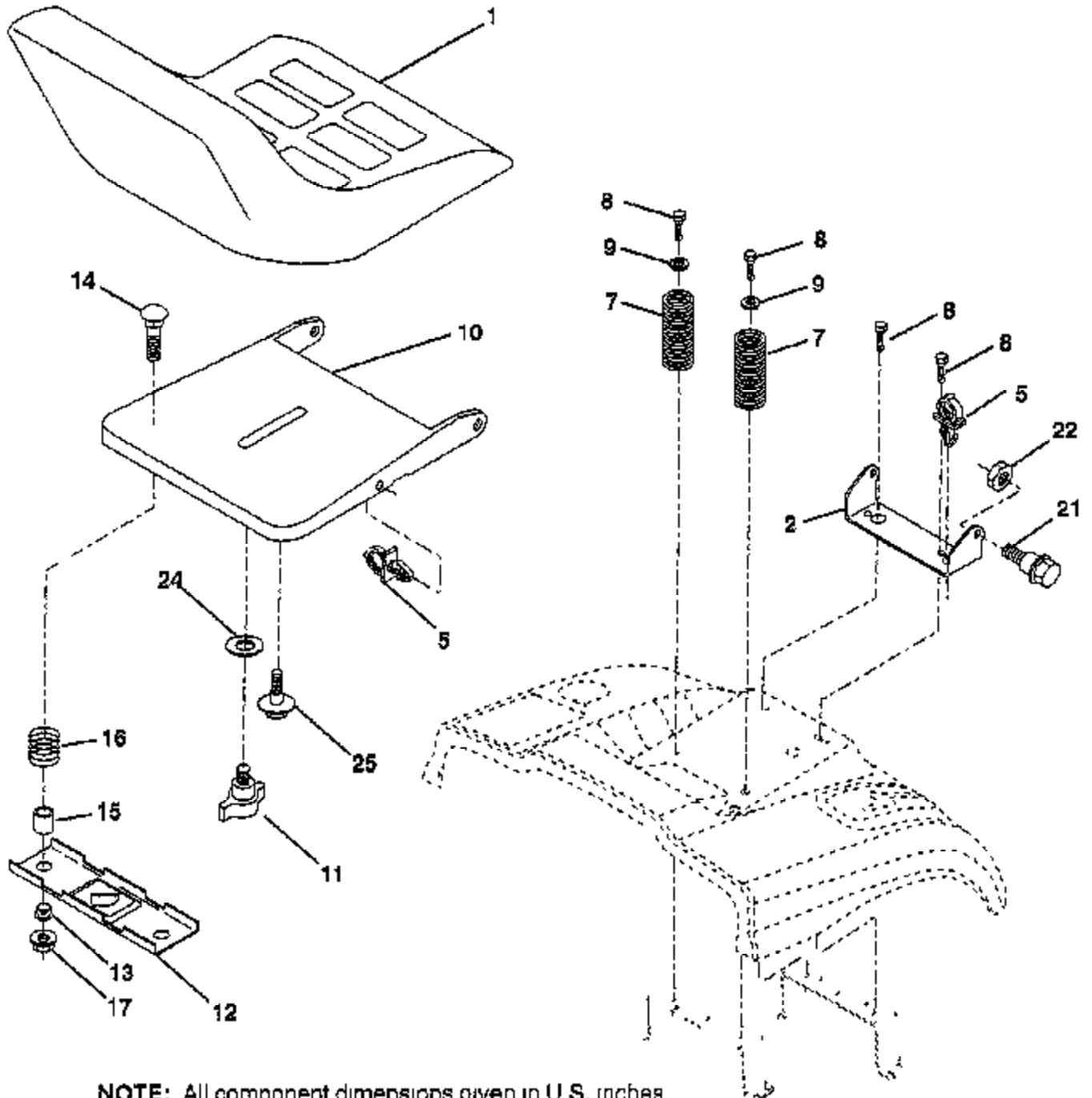

NOTE: All component dimensions given in U.S. inches
1 inch = 25.4 mm

Ref #	Part Number	Qty	Description
1	140117		SEAT.2400/1416.BK
2	140551		BRACKET PVT SEAT
5	145006		CLIP.PUSH-IN.HING
7	124181X		SPRING COMPRESSIO
8	17060616		SCREW
9	19131614		WASHER
10	155925		PAN-SEAT
11	166369		KNOB.SEAT.ADJ.WINGNUT
12	121246X		BRKT SWITCH
13	121248X		BUSHING
14	72050412		BOLT-RD HD SQ NK
15	134300		SPLIT SPACER
16	121250X		SPRING
17	123976X		SUB= 73900400
21	171852		BOLT
22	73800500		NUT
24	19171912		WASHER
25	127018X		"BOLT,SHOULDER"

TRACTOR- -MODEL NO. MBA1392B

STEERING ASSEMBLY

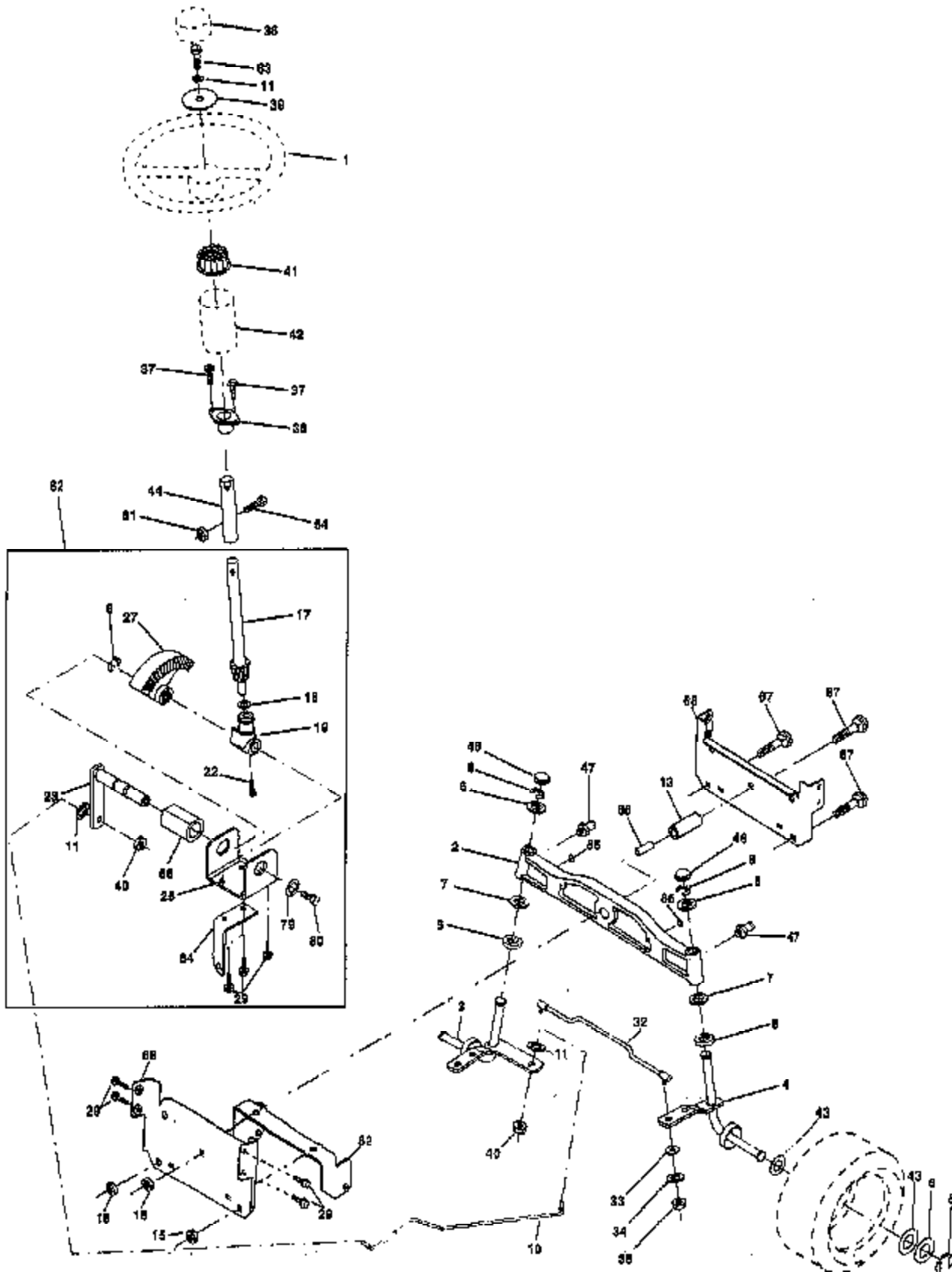

Ref #	Part Number	Qty	Description
1	139768		SUB= 150547
2	172393		AXLE ASM CAST IRON LT
3	169840		SPINDLE ASM
4	169839		SPINDLE ASM
5	6266H		WASHER .T
6	121748X		WASHER
7	19272016		WASHER
8	12000029		RING
10	169832		LINK DRAG
11	10040600		LOCKWASHER
13	136518		SPACER BEARING
15	145212		NUT.HXFLG.LOCK.
17	156546		SHAFT ASM STEERIN
18	57079		THRUST WASHER
19	160395		SUPPORT.SHAFT.STEER
22	165857		SCREW.HX.WSH.HD
23	165851		SHAFT.ASM.PITMAN
25	154406		BRKT-STEERING
27	136874		GEAR SECTOR
29	17060612		SCREW
32	170162		TIE ROD
33	19111216		WASHER M
34	10040500		LOCKWASHER
35	73810500		NUT.LOCK.5/16-24
36	155099		BUSHING.STEERING
37	152927		"SCREW-TT,10-32 FL"
38	140175		CAP WHEEL STEER
39	19133812		WASHER
40	7810H		GRIPCO NUT
41	100711L		ADAPTER LT
42	145054X428		BOOT.STEERING.DASH.P/L
43	121749X		WASHER
44	153720		EXT SHAFT STEERIN
46	121232X		CAP
47	6855M		ZERK M
51	73800500		NUT
54	74780520		BOLT
62	167902		KIT.STEER.ASM
63	74780616		BOLT
65	160367		"SPACER BRCAE,AXLE"
66	154404		"BEARING-ARM,PITMA"
67	72140618		BOLT RDHD 3/8-16
68	169827		BRACE AXLE
79	19132012		WASHER
80	74950612		BOLT.HX.NYLON3/8-16X3/
82	169635		METER HOUR
84	170016		BRACKET CABLE CLUTCH CHASSIS
85	133835		XMAS TREE FASTNER

WHEELS & TIRES

TRACTOR- -MODEL NO. MBA1392B

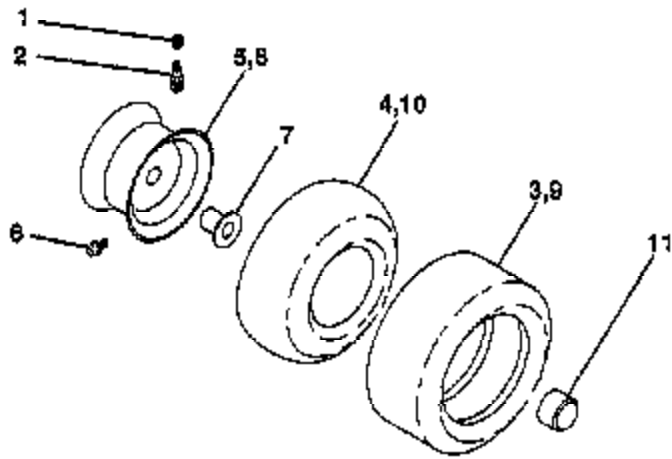

NOTE: All component dimensions given in U.S. inches
1 inch = 25.4 mm

Ref #	Part Number	Qty	Description
1	59192		VALVE CAP
2	65139		VALVE STEM LT
3	106222X		SUB= 122073X
4	59904		TUBE.5.3/4.5/6
5	106732X427		"RIM ASM 6"" FRT"
6	278H		FITTING LT
7	9040H		"FLANGE, BEARING"
8	106108X427		"RIM AS 8"" REAR"
9	124635X		SUB= 126957X
10	7152J		TUBE.18X9.5-8
11	104757X		HUB CAP
	144334		SEALANT.TIRE 10 OZ. TUBE