

REPAIR PARTS MANUAL
MODEL NO. 15.5HP-107CM (CM155107A)
Lawn Tractor

PREDATOR

HOW TO USE THIS MANUAL

This manual is designed to provide the customer with a means to identify the parts on his/her tractor when ordering repair parts. The illustrations may or may not represent the actual assemblies; therefore, it is not recommended to use this manual as a guide to assemble or disassemble the tractor. Some hardware and parts are drawn larger in order to more readily identify them.

Each tractor has its own model number.

The model number for your tractor can be found on the fender under the seat.

When ordering parts, always give the following information:

- Product - "Lawn Tractor"
- Model Number - 15.5HP-107CM (CM155107A)
- Part Number
- Part Description

TABLE OF CONTENTS

SCHEMATIC	3
ELECTRICAL.....	4-5
CHASSIS AND ENCLOSURES.....	6-7
DRIVE.....	8-9
STEERING WHEEL	10-11
ENGINE.....	12-13
SEAT	14
DECAL	15
MOWER DECK	16-17
MOWER LIFT	18-19

TRACTOR - MODEL NO. 15.5HP-107CM (CM155107A), PRODUCT NO. 964 79 55-00 SCHEMATIC

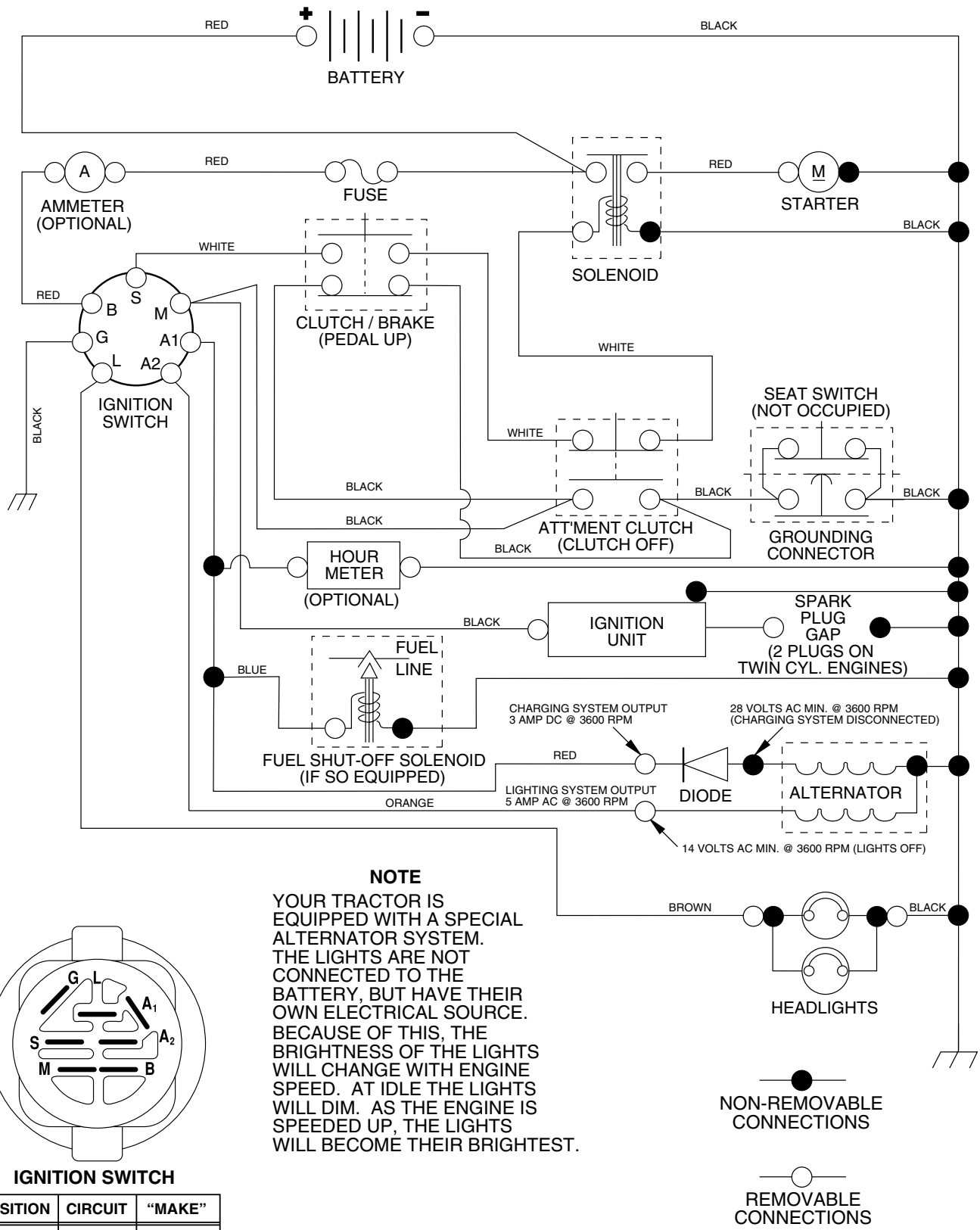

REPAIR PARTS

TRACTOR - MODEL NO. 15.5HP-107CM (CM155107A), PRODUCT NO. 964 79 55-00
ELECTRICAL

KEY NO.	PART NO.	DESCRIPTION
1	532 16 34-65	Battery 12 Volt 28 AMP
2	874 76 04-12	Bolt Hex Hd 1/4-20unc X 3/4
8	532 17 66-89	Battery Box Fender
16	532 17 61-38	Switch Interlock Push-In
21	532 17 56-85	Harness Asm Light W/4152j
22	532 00 41-52	Bulb Light #1156
24	532 10 84-23	Cable Battery 6 Ga 11" red
25	532 14 61-47	Cable Battery 6 Ga 44" red w/16 wire
26	532 17 51-58	Fuse
27	873 51 04-00	Nut Keps Hex 1/4-20 Unc
28	532 12 47-73	Cable Ground 6 Ga 12" black
29	532 12 13-05	Switch Plunger Nc Gray
30	532 17 55-66	Switch Ign
33	532 14 04-01	Key Ign Molded Generic
40	532 17 97-20	Harness Ign.
41	871 11 04-08	Bolt Blk Fin Hex 1/4 - 20 x 1/2
42	532 13 15-63	Cover Terminal Red
43	532 17 88-61	Solenoid
48	532 14 08-44	Adapter Ammeter Rectangular
52	532 14 19-40	Protection Wire Loop
90	532 18 04-49	Cover Terminal

NOTE: All component dimensions given in U.S. inches.
1 inch = 25.4 mm.

REPAIR PARTS

TRACTOR - MODEL NO. 15.5HP-107CM (CM155107A), PRODUCT NO. 964 79 55-00
CHASSIS AND ENCLOSURES

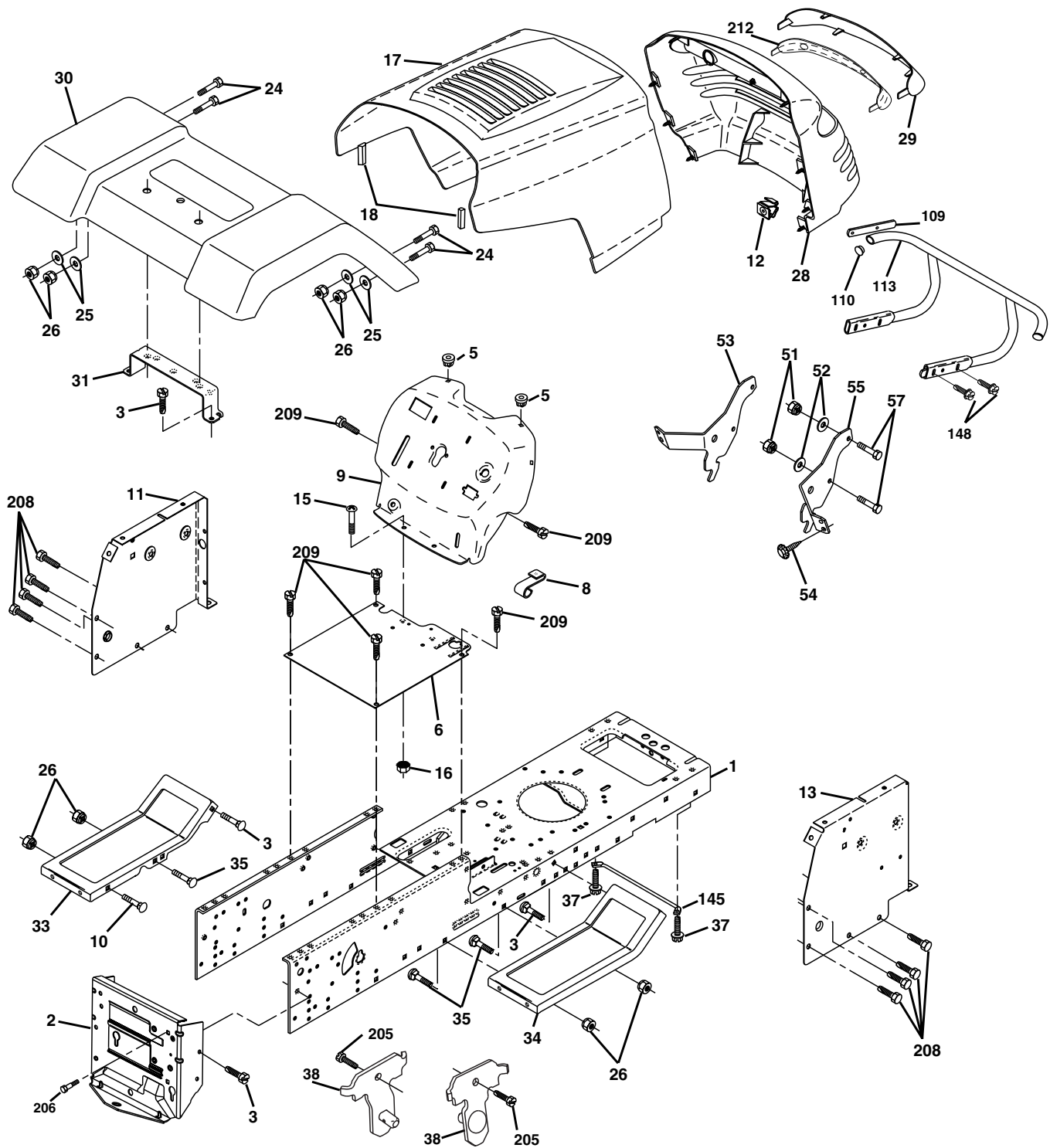

REPAIR PARTS

TRACTOR - MODEL NO. 15.5HP-107CM (CM155107A), PRODUCT NO. 964 79 55-00 CHASSIS AND ENCLOSURES

KEY NO.	PART NO.	DESCRIPTION
1	532 17 46-20	Chassis Stamping
2	532 17 65-54	Drawbar
3	817 06 06-12	Screw 3/8-16x3/4
5	532 15 52-72	Bumper Hood/Dash
6	532 18 44-19	Saddle Flat LT Fender Shift
8	532 15 51-38	Clip Retainer
9	532 18 54-80	Dash P/L
10	872 14 06-08	Bolt Carriage 3/8-16 x 1
11	532 17 49-96	Panel Dash Lh
12	532 14 56-60	Clip Tinnerman Grille P/L
13	532 18 17-19	Panel Dash Rh
15	874 18 05-12	Screw Mach Trhd 5/16-18 Unc x 3/4
16	873 51 05-00	Nut Keps 5/16-18 Unc
17	532 18 25-05	Hood
18	532 18 49-21	Bumper Hood
24	874 78 06-16	Bolt Fin Hex 3/8-16 Unc x 1 Gr 5
25	819 13 13-12	Washer 13/32 X 13/16 X 12 Ga
26	873 80 06-00	Nut Lock Hex W/Ins 3/8-16 Unc
28	532 17 91-01	Grille/Lens asm
29	532 16 81-54	Lens Grille
30	532 17 37-48	Fender
31	532 13 66-19	Bracket Support Fender
33	532 18 30-81	Footrest Pnt LH
34	532 18 30-80	Footrest Pnt RH
35	872 11 06-06	Bolt RDHD Sht SQNK 3/8-16 x 3/4
37	817 49 05-08	Screw Thdrol 6/16-18 x 1/2 TYT
38	532 17 57-10	Bracket Asm Pivot Mower Rear
51	873 80 04-00	Nut Lock Hex W/Ins 1/4-20
52	819 09 14-16	Washer 9/32 x 7/8 x 16 Ga.
53	532 14 46-97	Bracket Grille LH
54	532 16 14-64	Screw Hex Wshd 8-18 x 7/8
55	532 14 46-96	Bracket Grille RH
57	874 78 04-12	Bolt Hex 1/4-20 x 3/4
58	532 15 01-27	Duct Air Engine
109	532 17 03-10	Bracket Ext. Bumper
110	532 14 36-79	Plug Plastic
113	532 17 03-11	Bumper Asm.
145	532 15 65-24	Rod Pivot Chassis/Hood
148	817 06 06-20	Screw 3/8-16 x 1-1/4
205	817 49 06-08	Screw Thdrol 3/8-16 x 1/2
206	532 17 01-65	Bolt Shoulder 5/16-18 TT
208	817 67 06-08	Screw Thdrol 3/18-16 x 1/2
209	817 00 06-12	Screw Hexwsh Thdrl 3/8-16 x 3/4
212	532 15 62-29	Insert Lens Reflective
--	532 00 54-79	Plug Button

NOTE: All component dimensions given in U.S. inches
1 inch = 25.4 mm

REPAIR PARTS

TRACTOR - MODEL NO. 15.5HP-107CM (CM155107A), PRODUCT NO. 964 79 55-00
DRIVE

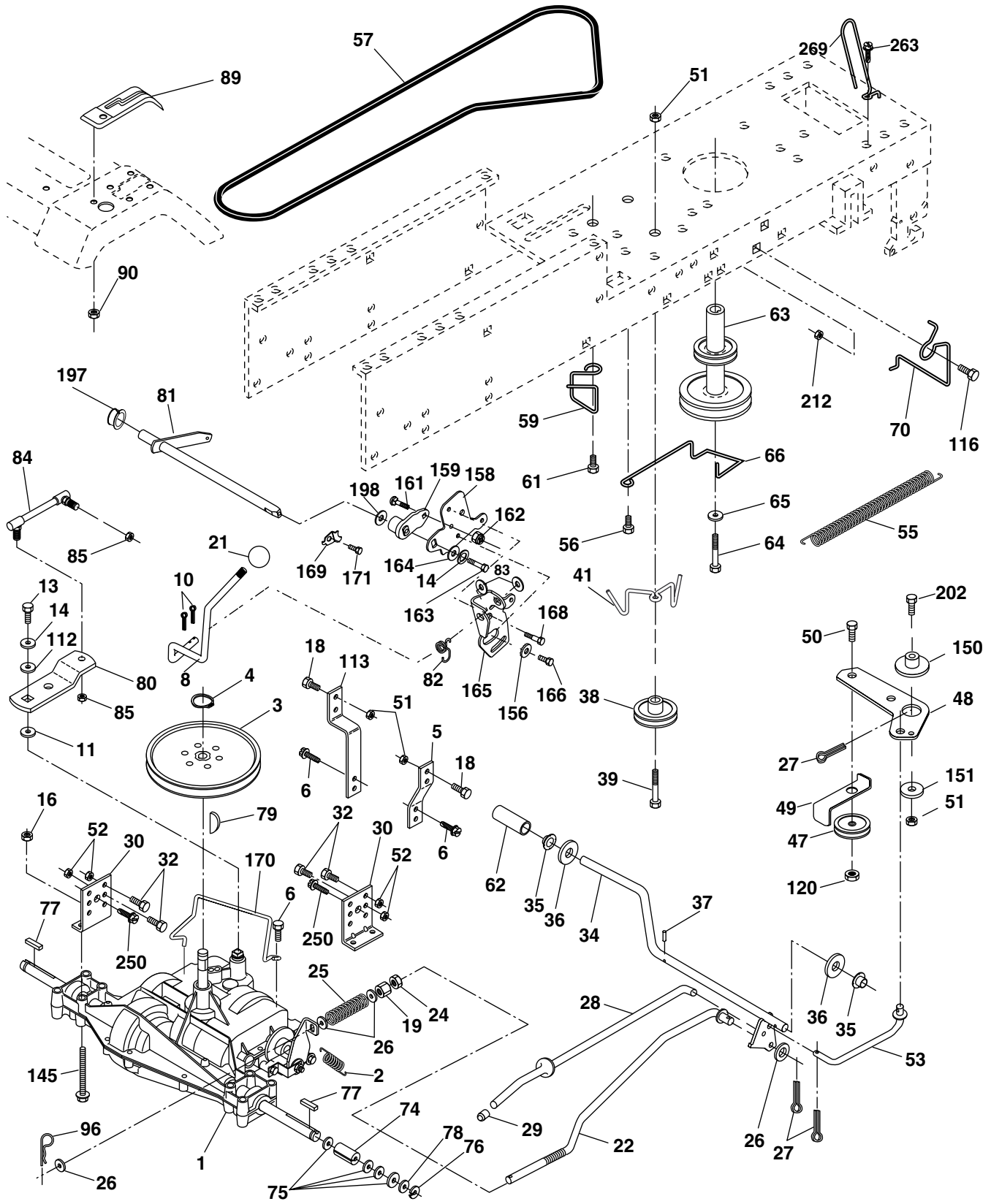

REPAIR PARTS

**TRACTOR - MODEL NO. 15.5HP-107CM (CM155107A), PRODUCT NO. 964 79 55-00
DRIVE**

KEY NO.	PART NO.	DESCRIPTION	KEY NO.	PART NO.	DESCRIPTION
1	-----	Transaxle Peerless 205-544C (Order parts from transaxle manufacturer)	64	871 17 07-64	Bolt Hex 7/16-20 x 4
2	532 14 66-82	Spring Return Brake T/a Zinc	65	810 04 07-00	Washer Lock Hvy Hlcl Spr 7/16
3	532 12 36-66	Pulley Transaxle 18"tires	66	532 15 47-78	Keeper Belt Engine F-Proof
4	812 00 00-28	Ring Retainer # 5100-62	70	532 18 02-18	Guide Belt Mower Drive RH
5	532 12 15-20	Strap Torque 30 Degrees	74	532 13 70-57	Spacer Axle
6	817 06 05-12	Screw 5/16-18 X 3/4	75	532 12 17-49	Washer 25/32 X 1 1/4 X 16 Ga
8	532 16 56-19	Rod Shifter	76	812 00 00-01	E-ring #5133-75
10	876 02 04-16	Pin Cotter 1/8 X 1 Cad	77	532 12 35-83	Key Square 2 0 X 1845/ 1865
11	532 10 57-01	Washer Plate Shf 388 Sq Hole	78	532 12 17-48	Washer 25/32 X 1-5/8 X 16 Ga
13	874 55 04-12	Bolt 1/4-28 Unf Gr 8 W/Patch	79	532 12 50-96	Key Woodruff
14	810 04 04-00	Washer Lock Hvy Helical 1/4	80	532 13 14-86	Arm Shift Transaxle
16	873 80 05-00	Nut Lock Hx W/Ins 5/16-18 Unc	81	532 16 55-94	Shaft Asm Cross
18	874 78 06-16	Bolt Fin Hex 3/8-16 UNC x `1 Gr. 5	82	532 12 37-82	Spring Torsion T/a
19	873 80 06-00	Nut Lock 3/8-16 Unc	83	819 17 12-16	Washer 17/32 X 3/4 X 16 Ga
21	532 10 69-33	Knob 1/2-13	84	532 16 62-28	Link Transaxle
22	532 13 08-04	Rod Brake Blk Zinc 26 840	85	532 15 03-60	Nut Nylock 1/4 - 28
24	873 35 06-00	Nut Hex Jam 3/8-16 Unc	89	532 17 37-74	Console Shift
25	532 10 68-88	Spring Rod Brake 2 00 Zinc	90	532 12 43-46	Nut Self-thd Wsh-hd 1/4 Zinc
26	819 13 13-16	Washer 13/32 X 13/16 X 16 Ga	96	532 12 47-88	Retainer Spring 1" Zinc/Cad
27	876 02 04-12	Pin Cotter 1/8 X 3/4 Cad	112	819 09 12-10	Washer 9/32 x 3/4 x 10 Ga.
28	532 17 57-65	Rod Brake Parking LT/YT	113	532 12 72-85	Strap Torque Lt
29	532 07 16-73	Cap Brake Parking Black	116	872 14 06-08	Bolt Rd Sq Neck 3/8-16 x 1
30	532 17 49-73	Bracket Mtg Transaxle	120	873 90 06-00	Nut Lock Flg 3/8-16
32	874 76 05-12	Bolt Hex Hd 5/16-18unc X 3/4	145	874 49 05-40	Bolt Hex 5/16-18FLGHD
34	532 17 55-78	Shaft Asm Pedal Foot	150	532 17 54-56	Spacer Retainer
35	532 12 01-83	Bearing Nylon Blk 629 Id	151	819 13 32-10	Washer 13/32 x 2 x 10 Ga.
36	819 21 16-16	Washer 21/32 X 1 X 16 Ga	156	532 16 60-02	Washer Srrted 5/16 ID x 1 .125
37	532 12 49-63	Pin Roll 3/16 X 1"	158	532 16 55-89	Bracket Shift Mount
38	532 17 91-14	Pulley Composite Flat	159	532 18 39-00	Hub Shift
39	874 76 06-48	Bolt Fin Hex 3/8-16 Unc x 3	161	872 14 04-06	Bolt Rdhd Sqnk 1/4-20 x 3/4 Gr 5
41	532 17 55-56	Keeper Belt Idler	162	873 68 04-00	Nut Crownlock 1/4-20 Unc
47	532 12 77-83	Pulley Idler V Groove Plastic	163	874 78 04-16	Bolt Hex Fin 1/4-20 Unc x 1 Gr. 5
48	532 15 44-07	Bellcrank Clutch Grnd Drw STL	164	819 09 10-10	Washer 5/8 x .281 x 10 Ga.
49	532 12 32-05	Retainer Belt Style Spring	165	532 16 56-23	Bracket Pivot Lever
50	872 11 06-12	Bolt Hex Hd 3/8-16unc X 1-1/2	166	532 16 68-80	Screw 5/16-18 x 5/8
51	873 68 06-00	Nut Crownlock 3/8-16 Unc	168	532 16 54-92	Bolt Shoulder 5/16-18 x .561
52	873 68 05-00	Nut Crownlock 5/16-18 Unc	169	532 16 55-81	Plate Fastening LT
53	532 10 57-10	Link Clutch 7 66	170	532 17 83-94	Keeper Belt Transaxle
55	532 10 57-09	Spring Return Clutch 6 75	171	817 49 06-08	Screw Thdrol 3/8-16 x 1/2
56	817 06 06-20	Screw 3/8-16 X 1-1/4	197	532 16 96-13	Nyliner Snap-In 5/8" ID
57	532 13 08-01	V-Belt Ground Drive 95 25 42"	198	532 16 95-93	Washer Nyl 7/8 ID x .105"
59	532 16 96-91	Keeper Belt Span Ctr	202	872 11 06-14	Bolt Carr Sh 3/8-16 x 1-1/2 Gr 5
61	817 12 06-14	Screw 3/8-16 x .875	212	532 14 52-12	Nut Hex Flg Lock
62	532 12 48-72	Cover Pedal	250	817 06 06-12	Screw 3/8-16 x .75
63	532 18 02-19	Engine Pulley			

NOTE: All component dimensions given in U.S. inches
1 inch = 25.4 mm

REPAIR PARTS

TRACTOR - MODEL NO. 15.5HP-107CM (CM155107A), PRODUCT NO. 964 79 55-00
STEERING ASSEMBLY

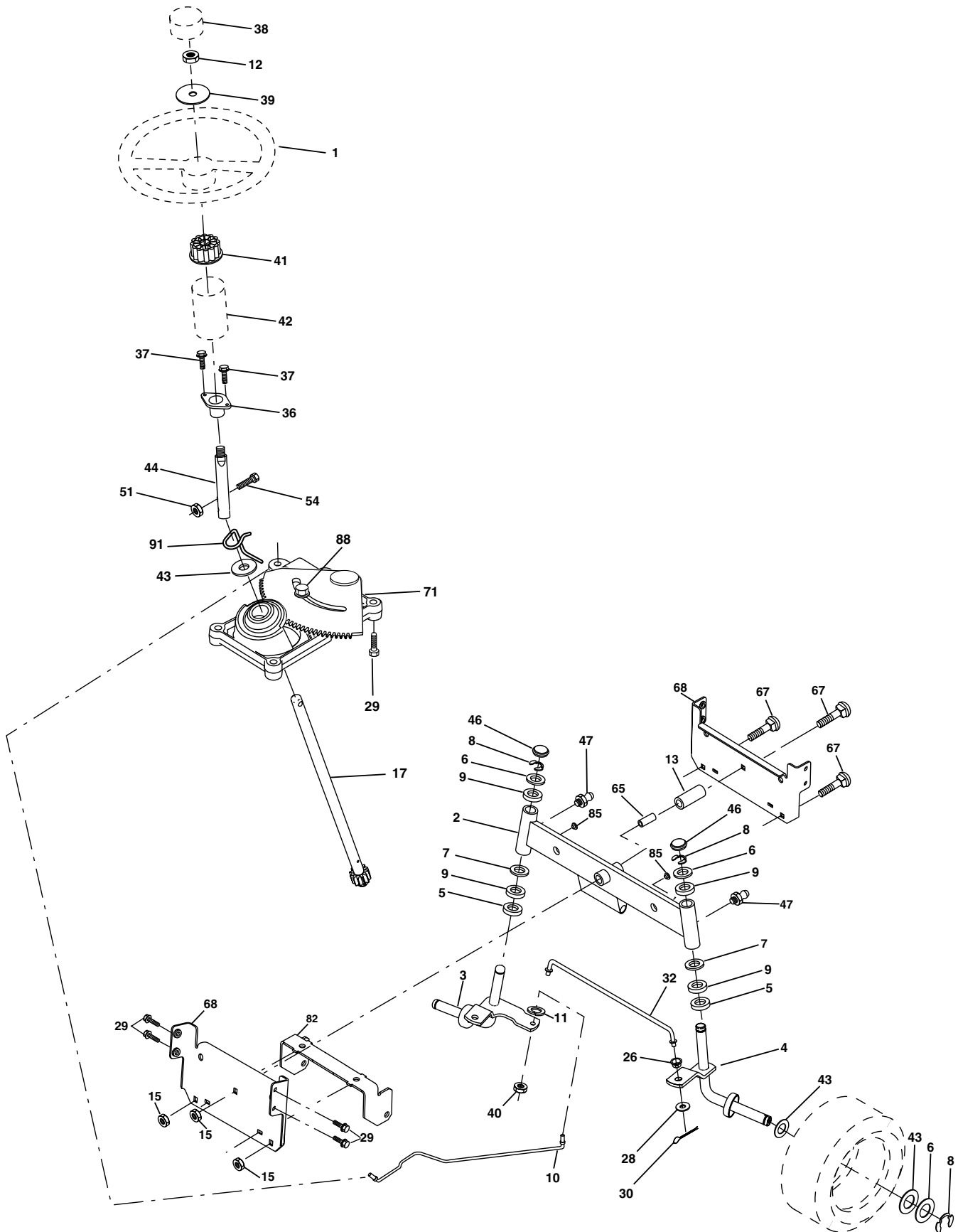

REPAIR PARTS

TRACTOR - MODEL NO. 15.5HP-107CM (CM155107A), PRODUCT NO. 964 79 55-00
STEERING ASSEMBLY

KEY NO.	PART NO.	DESCRIPTION
1	532 17 59-04	Wheel Steering
2	532 17 51-31	Axle Asm STMP Dropped STL
3	532 16 98-40	Spindle Asm LH
4	532 16 98-39	Spindle Asm RH
5	532 12 49-31	Bearing Race Thrust Harden
6	532 12 17-48	Washer 25/32 X 1-5/8 X 16 Ga
7	819 27 20-16	Washer 27/32 X 1-1/4 X 16 Ga
8	812 00 00-29	Ring Klip #15304-75
9	532 12 49-37	Bearing Col Strg Blk
10	532 17 51-21	Link Drag
11	810 04 06-00	Washer Lock Hvy Hlcl Spr 3/8
12	873 94 08-00	Nut Hex Jam Toplock 1/2-20
13	532 13 65-18	Spacer Brg Axle Front
15	532 14 52-12	Nut Hex Flange Lock
17	532 18 06-41	Shaft Asm Strg
26	532 12 68-47	Bushing Link Drag
28	819 13 14-16	Washer 13/32 X 7/8 X 16ga.
29	817 06 06-12	Screw 3/8-16x3/4
30	876 02 04-12	Pin Cotter 1/8 X 3/4 Cad.
32	532 13 04-65	Rod Tie
36	532 15 50-99	Bushing Strg
37	532 15 29-27	Screw
38	532 17 59-05	Insert Cap Strg Wh
39	819 18 38-12	Washer 9/16 x 2-3/8
40	532 12 47-01	Lock nut
41	532 10 07-11	Adaptor Wheel Strg
42	532 16 96-33	Boot Steering Shaft
43	532 12 17-49	Washer 25/32 X 1 1/4 X 16 Ga
44	532 18 06-40	Extension Steering
46	532 12 12-32	Cap Spindle Fr Top Blk
47	532 18 32-26	Fitting Grease
51	873 54 04-00	Nut 1/4-28
54	871 13 04-20	Bolt Hex 1/4-28 x 1-1/4
65	532 16 03-67	Spacer Brace Axle
67	872 14 06-18	Bolt Rdhd Sq 3/8-16 x 2-1/4
68	532 16 98-27	Axle, Brace
71	532 17 51-46	Steering Asm
82	532 16 98-35	Bracket Susp Chassis Front
85	532 13 38-35	Fastner Christmas Tree
88	532 17 51-18	Bolt Shoulder 7/16-20
91	532 17 55-53	Clip Steering

NOTE: All component dimensions given in U.S. inches.
1 inch = 25.4 mm.

REPAIR PARTS

TRACTOR - MODEL NO. 15.5HP-107CM (CM155107A), PRODUCT NO. 964 79 55-00
ENGINE

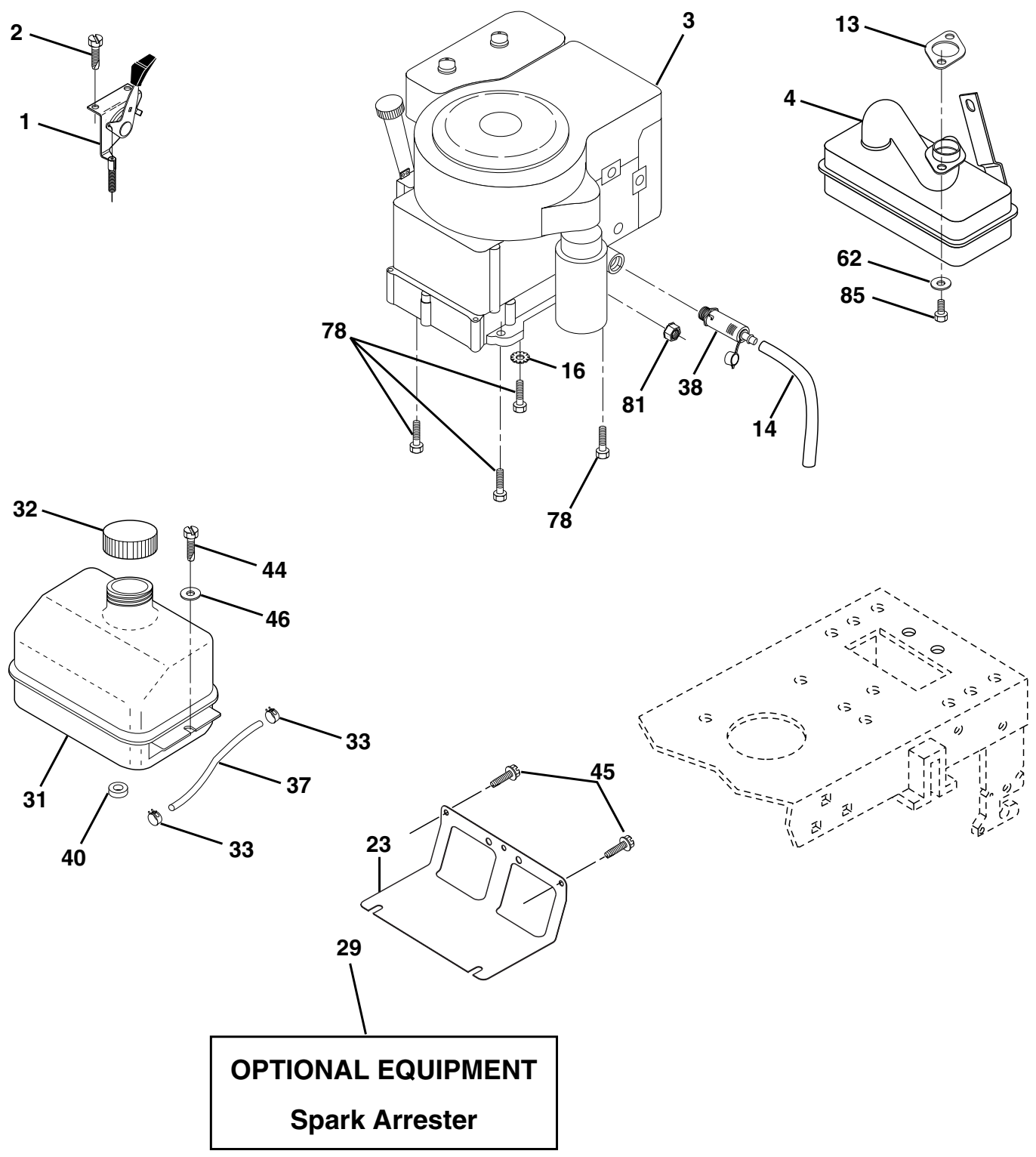

REPAIR PARTS

TRACTOR - MODEL NO. 15.5HP-107CM (CM155107A), PRODUCT NO. 964 79 55-00
ENGINE

KEY NO.	PART NO.	DESCRIPTION
1	532 17 05-51	Control Th/ch
2	817 72 04-08	Screw Hex Thd Cut 1/4-20 x 1/2
3	-----	Engine TEC Model No. OHV175 Order parts from engine manufacturer
4	532 13 73-51	Muffler LT B&S
13	532 14 92-72	Gasket
14	532 14 84-56	Tube Drain Oil Easy
16	811 05 06-00	Washer Lock Ext Tooth 3/8
23	532 16 98-37	Shield Brn/Dbr Guard
29	532 13 71-80	Kit Spark Arrestor (Flat Scrn)
31	532 18 49-00	Tank Fuel
32	532 14 05-27	Cap Asm Fuel W/sym Vented
33	532 12 34-87	Clamp Hose Black
37	532 13 70-40	Line Fuel 20"
38	532 18 16-54	Plug Drain Oil Easy
40	532 12 40-28	Bushing Snap Nyl Blk Fuel Line
44	817 67 04-12	Screw Hexwsh Thdrol 1/4-20x3/4
45	817 00 06-12	Screw Hexwsh Thdr 3/8-16 x 3/4
46	819 09 14-16	Washer 9/32 X 7/8 X 16 Ga
62	810 04 05-00	Washer Lock Hvy Hlcl Spr 5/16
78	817 06 06-20	Screw 3/8-16x1-1/4
81	873 51 04-00	Nut Keps Hex 1/4-20 Unc
85	532 12 35-28	Bolt Hex Hd Phillips

NOTE: All component dimensions given in U.S. inches
1 inch = 25.4 mm

REPAIR PARTS

TRACTOR - MODEL NO. 15.5HP-107CM (CM155107A), PRODUCT NO. 964 79 55-00

SEAT ASSEMBLY

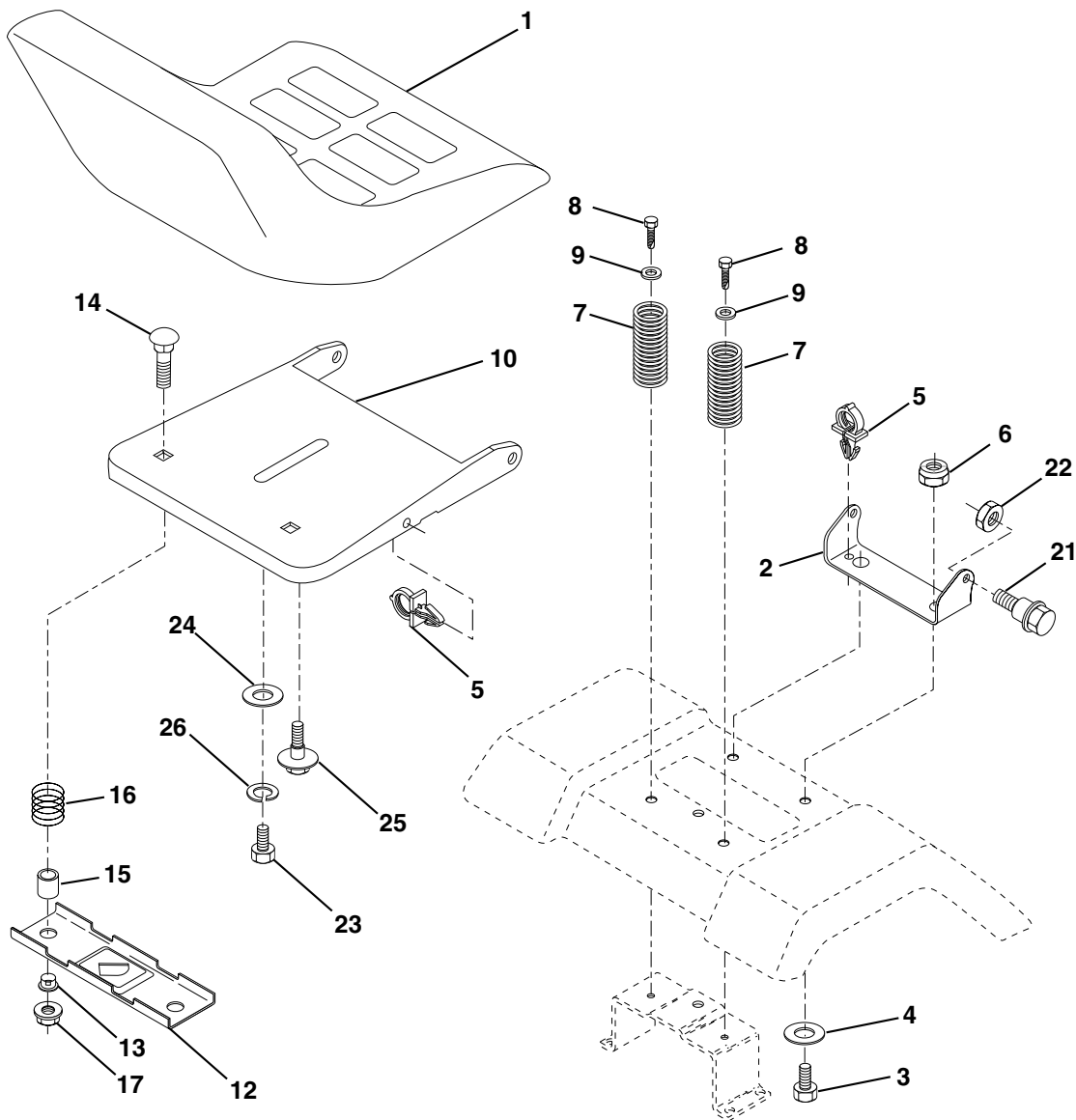

KEY NO.	PART NO.	DESCRIPTION
1	532 12 74-27	Seat
2	532 14 05-51	Bracket Pivot Seat 8 720
3	871 11 06-16	Bolt Fin Hex 3/8-16unc X 1
4	819 13 16-10	Washer 13/32 X 1 X 10 Ga
5	532 14 50-06	Clip Push-In
6	873 80 06-00	Nut Hex w/Ins. 3/8-16 Unc
7	532 12 41-81	Spring Seat Cprsn 2 250 Blk Zi
8	817 00 06-16	Screw 3/8-16 X 1-1/2
9	819 13 16-14	Washer 13/32 X 1 X 14 Ga.
10	532 18 24-93	Pan Seat
12	532 12 12-46	Bracket Mounting Switch
13	532 12 12-48	Bushing Snap Blk Nyl 50 Id

KEY NO.	PART NO.	DESCRIPTION
14	872 05 04-12	Bolt Rdhd Sqnk 1/4-20x1-1/2
15	532 13 43-00	Spacer Split 28x96 Yel Zinc
16	532 12 12-50	Spring Cprsn 1 327 Blk Pnt
17	532 12 39-76	Nut Lock 1/4 Lge Flg Gr 5 Zinc
21	532 17 18-52	Bolt Shoulder 5/16-18 Unc
22	873 80 05-00	Nut Hex Lock W/Ins 5/16-18
23	871 11 08-14	Bolt Hex Black
24	819 17 19-12	Washer 17/32 X 1-3/16 X 12 Ga.
25	532 12 70-18	Bolt Shoulder 5/16-18 X 62
26	810 04 08-00	Washer Lock Hvy HLCL Spr 1/2

NOTE: All component dimensions given in U.S. inches.
1 inch = 25.4 mm

REPAIR PARTS

TRACTOR - MODEL NO. 15.5HP-107CM (CM155107A), PRODUCT NO. 964 79 55-00
DECALS

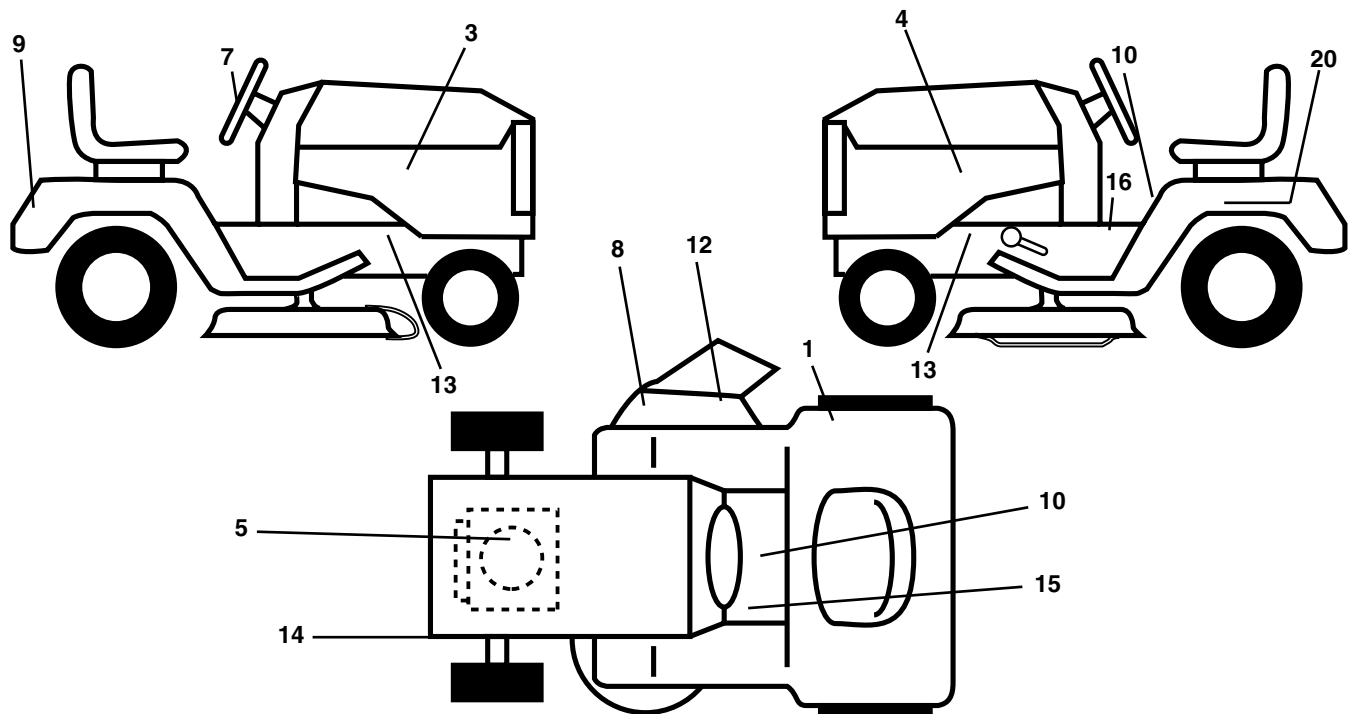

KEY NO.	PART NO.	DESCRIPTION
1	532 18 04-32	Decal 100 DBA
3	532 18 61-20	Decal Hood RH
4	532 18 61-21	Decal Hood LH
5	532 16 38-61	Decal HP Engine
7	532 18 60-87	Decal Ins. Strg Whl.
8	532 18 21-66	Decal Mower Cutting
9	532 18 61-22	Decal Fender
10	532 14 54-98	Decal Read Owner's Manual Syms.
12	532 17 91-28	Decal Deck "B" 42"

KEY NO.	PART NO.	DESCRIPTION
13	532 15 97-36	Decal Chassis Hot Muffler
14	532 16 03-96	Decal V-Belt Schematic
15	532 15 97-37	Decal Brake/Clutch Symbol Lt
16	532 14 08-37	Decal Saddle Brake Parking
20	532 14 50-05	Decal Bat Dan/Psn
--	532 13 83-11	Decal Handle Lift Height Adjust
--	532 16 25-98	Decal Drawbar Load Limit
--	532 18 60-81	Manual Parts
--	532 18 60-80	Manual Operator's (Euro.)

WHEELS & TIRES

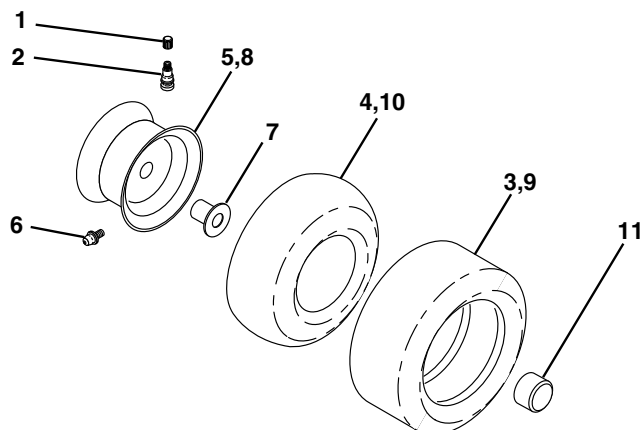

KEY NO.	PART NO.	DESCRIPTION
1	532 05 91-92	Cap Valve Tire
2	532 06 51-39	Stem Valve
3	532 10 62-22	Tire FTs 15 X 6 0 - 6 Service
4	532 05 99-04	Tube Front (Service Item Only)
5	532 12 51-21	Rim Asm 6"front Service
6	532 12 49-57	Fitting Grease (Front Wheel Only)
7	532 12 49-59	Bearing Flange (Front Wheel Only)
8	532 12 51-22	Rim Asm 8"rear Service
9	532 10 62-68	Tire RTs 18 x 9-8 C Service
10	532 12 49-26	Tube Rear (Service Item Only)
11	532 17 50-39	Cap Axle Blk 1 50 X 1 00
--	532 14 43-34	Sealant, Tire (10 oz. Tube)

NOTE: All component dimensions given in U.S. inches
1 inch = 25.4 mm

REPAIR PARTS

**TRACTOR - MODEL NO. 15.5HP-107CM (CM155107A), PRODUCT NO. 964 79 55-00
MOWER DECK**

KEY NO.	PART NO.	DESCRIPTION	KEY NO.	PART NO.	DESCRIPTION
1	532 16 58-92	Mower Deck Assembly, 42"	59	532 17 34-42	Guard, TUV Idler
2	872 14 05-06	Bolt	67	532 10 69-32	Knob Round
3	532 13 80-17	Bracket Assembly, Sway Bar, Front	68	532 18 02-15	V-Belt
4	532 16 54-60	Bracket Sway Bar 38/42" Deck	111	532 18 30-74	Bracket, Gauge, Wheel L.H.
5	532 12 46-70	Retainer Spring	112	532 18 30-75	Bracket, Gauge, Wheel R.H.
6	532 17 80-24	Bar Sway Deck	113	817 06 05-10	Screw 5/16-18 x .625
8	532 85 08-57	Bolt, Hex 3/8-24 x 1.25 Gr. 8	114	873 51 05-00	Bolt, Carriage 5/16 UNC
9	810 03 06-00	Washer, Lock	115	872 11 05-05	Bolt, Carriage 5/16 Unc x 5/8
10	532 14 02-96	Washer, Hardened	116	532 12 48-42	Bolt, Shoulder
11	532 13 89-71	Blade, High Perf.	117	532 10 54-55	Wheel, Gauge
13	532 13 76-45	Shaft Assembly, Mandrel, Vented	118	873 93 06-00	Nut, Centerlock 3/8-16
14	532 12 87-74	Housing, Mandrel, Vented	119	819 12 14-14	Washer 3/8 x 7/8 x 14 Gauge
15	532 11 04-85	Bearing, Ball, Mandrel	120	819 17 15-12	Washer 17/32 x 15/16 x 12 Ga.
16	532 17 44-93	Stripper, Mandrel Deck	142	532 16 58-90	Arm Spring Brake Mower
18	872 14 05-05	Bolt, Carriage 5/16-18 x 5/8	143	532 15 71-09	Bracket Arm Idler 42"
19	532 13 28-27	Bolt, Shoulder	144	532 17 34-41	Keeper Belt 42" Clutch Cable
20	532 15 97-70	Baffle, Vortex	145	532 17 34-37	Pulley Idler Flat
21	873 68 05-00	Nut Crownlock 5/16-18 UNC	146	532 17 34-43	Bolt Carriage Idler
23	532 17 75-63	Bracket, Deflector	147	532 17 97-48	Spring Extension
24	532 10 53-04	Cap, Sleeve	148	532 16 90-22	Spring Return Idler
25	532 12 37-13	Spring, Torsion, Deflector	149	532 16 58-98	Retainer Spring Yellow Zinc
26	532 11 04-52	Nut, Push	150	819 09 12-16	Washer 9/32 x 3/4 x 16 Ga.
27	532 17 18-59	Shield, Deflector	151	532 16 96-70	Bracket Clutch
28	819 11 10-16	Washer 11/32 x 5/8 x 16 Ga.	152	532 18 15-55	Cable Clutch 42 In
29	532 13 14-91	Rod, Hinge	153	532 16 96-74	Washer Flat 3/8" Type B
30	532 17 39-84	Screw Thdrol	154	532 16 96-75	Spring Retainer
31	532 12 99-63	Washer, Spacer	155	532 16 96-71	Spring Retention Lever
32	532 17 34-36	Pulley, Mandrel	156	532 16 96-72	Spacer
33	532 17 83-42	Nut, Toplock, Flanged	157	532 16 96-69	Rod Clutch
34	872 11 06-14	Bolt	158	817 72 04-08	Screw Hex Thd Cut 1/4-20 x 1/2
36	532 17 34-38	Pulley, Idler, Flat	159	872 14 06-14	Bolt 3/8-16 x 1-3/4
37	819 13 13-16	Washer 13/32 x 13/16 x 16 Gauge	184	819 13 14-10	Washer 13/32 x 7/8 x 10 Ga.
40	873 68 06-00	Nut Crownlock 3/8-16 UNC	--	532 13 07-94	Mandrel Assembly (Includes Housing, Shaft and Shaft Hardware Only-Pulley not Included)
44	532 14 00-88	Guard, Mandrel, L.H.	--	532 18 14-07	Replacement Mower, Complete
45	532 12 47-88	Retainer			
46	532 13 77-29	Screw, Thd. Roll 1/4-20 x 5/8			
48	532 13 39-44	Washer, Hardened			
52	532 13 98-88	Bolt, Shoulder 5/16-18 UNC			
53	532 18 49-07	Arm Assembly, Pad, Brake			
54	532 17 85-15	Washer, Hardened			
55	532 15 50-46	Arm, Idler			
56	532 12 20-52	Spacer, Retainer			

NOTE: All component dimensions given in U.S. inches
1 inch = 25.4 mm

REPAIR PARTS

TRACTOR - MODEL NO. 15.5HP-107CM (CM155107A), PRODUCT NO. 964 79 55-00
MOWER LIFT

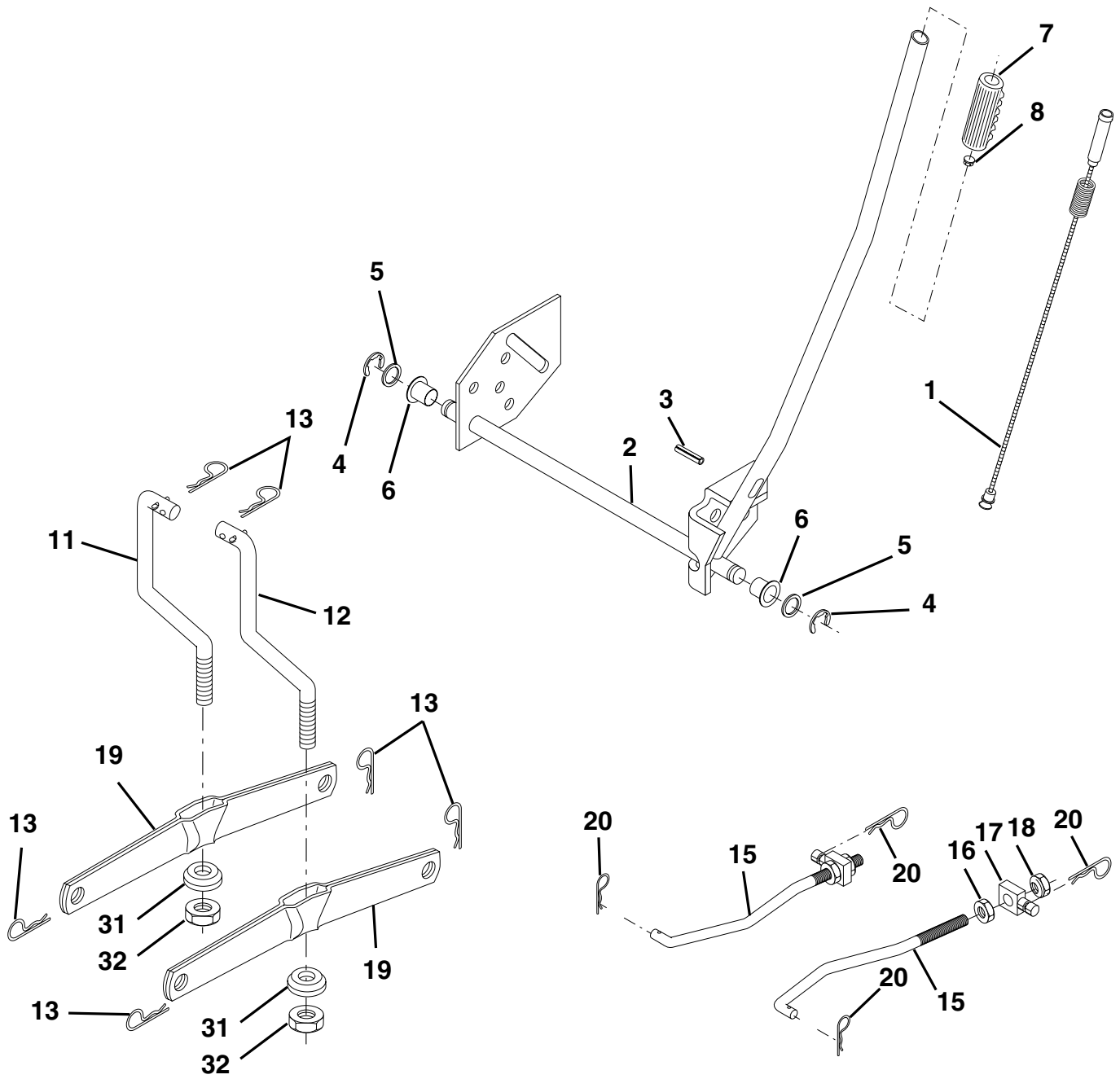

REPAIR PARTS

TRACTOR - MODEL NO. 15.5HP-107CM (CM155107A), PRODUCT NO. 964 79 55-00
MOWER LIFT

KEY NO.	PART NO.	DESCRIPTION
1	532 15 94-60	Wire Asm Inner W/plunger
2	532 15 94-71	Shaft Asm Lift RH
3	532 10 57-67	Pin Groove 1 500 Zinc
4	812 00 00-02	E Ring #5133-62
5	819 21 16-21	Washer 21/32 X 1 X 21 Ga
6	532 12 01-83	Bearing Nylon Blk 629 Id
7	532 10 94-13	Grip Handle
8	532 12 45-26	Button Plunger
11	532 13 98-65	Link Lift LH Fixed Length
12	532 13 98-66	Link Lift RH Fixed Length
13	532 12 46-70	Retainer Spring
15	532 17 32-88	Link Front
16	873 35 08-00	Nut Jam Hex 1/2-13 Unc
17	532 17 56-89	Trunnion Blk Zinc
18	873 80 08-00	Nut Lock w/wsh 1/2-13 Unc
19	532 13 98-68	Arm Suspension Rear
20	532 16 35-52	Retainer Spring
31	532 16 98-65	Bearing Pvt Lift
32	873 54 06-00	Nut Crownlock 3/8-24

NOTE: All component dimensions given in U.S. inches
1 inch = 25.4 mm



SERVICE POLICY



Issued January 1980
Revised January 1991

WARRANTY

LIMITED WARRANTIES FOR NEW PEERLESS GEAR POWER TRAIN COMPONENTS

A. Products Warranted

Peerless Gear and Machine Division of Tecumseh Products Company ("Tecumseh"), subject to the limitations contained below, will, at its option, repair or replace, without charge for parts or labor only, any part of a new Power Train Component (which as used herein means and includes the transaxle, gear box, transmission, differential and right angle drives, and any part of the Power Train Component), EXCEPT any new Power Train Component incorporated in equipment used for commercial or rental purposes, which is found upon examination by any Tecumseh Authorized Service Outlet or by Tecumseh's factory in Grafton, Wisconsin, to be DEFECTIVE IN MATERIAL AND/OR WORKMANSHIP if received by Tecumseh or a Tecumseh Authorized Service Outlet for such examination within TWO YEARS from the date of sale to the original consumer purchaser of Peerless Series 820, 900, 910, 915, 920, 930 transaxles and Series 1100 angle drive and ONE YEAR for all other Peerless products. New Power Train Components incorporated in equipment used for commercial purposes are warranted in the same manner and to the same extent EXCEPT such Power Train Components are warranted for NINETY (90) DAYS ONLY, and must be received by Tecumseh or by a Tecumseh Authorized Service Outlet for such examination within 90 days from the date of sale to the original purchaser. New Power Train Components incorporated in equipment used for rental purposes are warranted in the same manner and to the same extent EXCEPT such Power Train Components are warranted for THIRTY (30) DAYS ONLY, and must be received by Tecumseh or a Tecumseh Authorized Service Outlet within 30 days from the date of sale to the original purchaser.

B. Products And Items Not Warranted

1. Alterations or Modifications of Power Train Components.
2. Accidents, Normal Maintenance, Failure to follow the Original Equipment Manufacturer's Manual.

This warranty covers only parts of new Power Train Components which are found upon examination to be defective in material or workmanship as delivered to the original purchaser. This warranty does not cover defects caused by depreciation or damage caused by normal wear, accidents, improper maintenance, improper use or abuse of the product, failure to follow the instructions contained in an Instruction Manual for the operation of the Power Train Component and parts. The cost of normal maintenance and replacement of service items which are not defective shall be paid for by the original purchaser.

C. Securing Warranty Service

Warranty service can be arranged for by contacting either a Tecumseh Authorized Service Outlet (any Tecumseh Registered Service Dealer, Tecumseh Authorized Service Distributor, or Tecumseh Central Warehouse Distributor) or by contacting Tecumseh, c/o Service Manager, Engine and Transmission Group Service Division, 900 North Street, Grafton, Wisconsin 53024. Warranty service can only be performed by a Tecumseh Authorized Service Outlet or by Tecumseh at its factory in Grafton, Wisconsin. At the time of requesting warranty service, evidence must be presented of the date of sale to the original purchaser. The purchaser shall pay any charges for making service calls and/or for transporting the product to and from the place where the inspection and/or warranty work is performed. The purchaser shall be responsible for any damage or loss incurred in connection with the transportation of Power Train Components and/or part(s) of the Power Train Components submitted for inspection and/or warranty work.

D. Limitation of Damages and Implied Warranties

The foregoing EXPRESSED WARRANTY IS IN LIEU OF ALL OTHER EXPRESS WARRANTIES. Neither Tecumseh nor any of its affiliates makes any warranties, representations or promises, written or oral, as to the quality of the Power Train Component or any of its parts, other than as set forth herein.

ANY IMPLIED WARRANTY OF MERCHANTABILITY OR FITNESS FOR A PARTICULAR PURPOSE, TO THE EXTENT THAT EITHER MAY APPLY TO ANY PART(S) OF POWER TRAIN COMPONENTS, SHALL BE LIMITED IN DURATION TO THE PERIODS OF THE EXPRESSED WARRANTIES DEFINED IN PARAGRAPH A HEREOF. IN NO EVENT WILL TECUMSEH BE LIABLE FOR ANY INCIDENTAL, CONSEQUENTIAL OR SPECIAL DAMAGES AND/OR EXPENSES. Some states do not allow limitations on how long an implied warranty lasts or the exclusion or limitation of incidental or consequential damages, so the above limitation(s) or exclusion(s) may not apply to you. This warranty gives you specific legal rights and you may also have other legal rights which vary from state to state.

E. No Dealer Warranty

Tecumseh neither assumes nor authorizes any other person, natural or corporate, to assume for Tecumseh any other obligations or liabilities in connection with or with respect to any part(s) of a Power Train Component. The seller or dealer of part(s) of a Power Train Component has no authority, whatsoever, to make any representations or promises on behalf of Tecumseh or to modify the terms or limitations of Tecumseh's warranty in any way.

PREDATOR