

Mountfield

Illustrated Parts List

2100 Series Mower Decks 85-95 Model Year 2008

- Use GLOBAL GARDEN PRODUCT Genuine Spare Parts specified in the parts list for repair and/or replacement.
- The contents described in the parts list may change due to improvement.
- The drawings of the spare parts are only indicative and might not represent the part in question exactly.
- The indications "right" - "left" - "front" - "rear" refer to the position of the operator when using the machine.
- When placing orders of parts for repair and/or replacement, make sure that the illustrated parts list is the one applying to the machine's year of manufacture, as shown on the identification plate attached to the machine.

COPYRIGHT by GLOBAL GARDEN PRODUCTS

All rights reserved. No part of this material may be reproduced or transmitted, in any form or by any means, electronic or mechanical, including photocopying, recording or by any information storage and retrieval system, without permission in writing from GLOBAL GARDEN PRODUCTS.

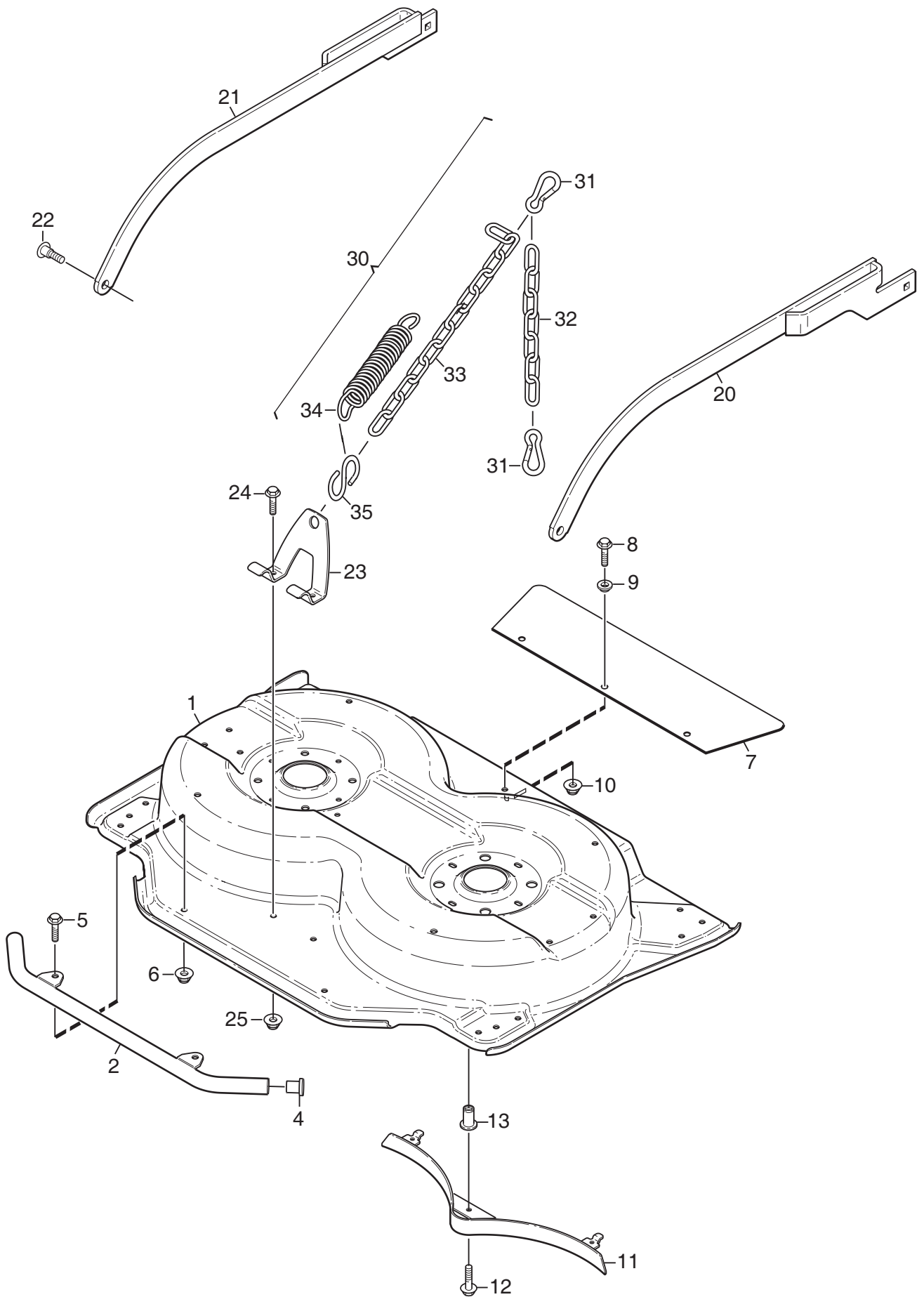

M319

Issue Ausgabe 2008-21		Picture No Bild Nr M319		2105M- 2125H MOWER DECK 85 COMBI FRAME		2105M- 2125H MÄHWERK 85 COMBI RAHMEN		Page Seite 58		
Fig. Pos.	Quantity/Anzahl				Part No. Artikel Nr.	Description	Bezeichnung	Kit Satz	Notes Anmerkung	
	2960 -92									
1	1				1134-6189-03	Casing- red	Haube- rot		Pos 13 incl.	
2	1				1134-6208-02	Front guard tube- bl.	Frontschutz- schwarz			
4	2				9403-0025-70	End cap- black	Propfen- schwarz			
5	2				9959-0816-16	Screw	Schraube			
6	2				9739-0831-22	Nut	Mutter			
7	1				1134-6281-01	Rubber guard	Gummischutz			
8	3				9959-0816-16	Screw	Schraube			
9	3				1134-4185-01	Flange washer	Flanschscheibe			
10	3				9739-0831-22	Nut	Mutter			
11	1				1134-6227-01	Mulching plug	Mulchpropfen			
12	1				9959-0816-16	Screw	Schraube			
13	1				1134-5595-01	• Riveting nut	• Nietmutter			
20	1				1134-6237-11	Deck arm- LH, black	Mähwerkarm- L, schw			
21	1				1134-6237-12	Deck arm- RH, black	Mähwerkarm- R, schw			
22	2				1134-6279-01	Shoulder bolt	Schulterschraube			
23	1				1134-6315-02	Lift bracket- black	Hebehalter- schw			
24	2				9959-0816-16	Screw	Schraube			
25	2				9739-0831-22	Nut	Mutter			
30	1				1134-6363-01	Lift spring assy	Hebefeder kpl			
31	2				1134-5528-01	• Snap hook	• Karabinerhaken			
32	1				1134-6368-02	• Chain	• Kette			
33	1				1134-6368-03	• Chain	• Kette			
34	1				1134-5625-01	• Mower deck spring	• Mähwerkfeder			
35	1				1134-4623-01	• S- hook	• S- Haken			
99	1				8211-7060-81	Owner's manual	Bedienungsanleitung			
										Pos 31 - 35 incl.
										7 links 12 links
										Not ill.

X

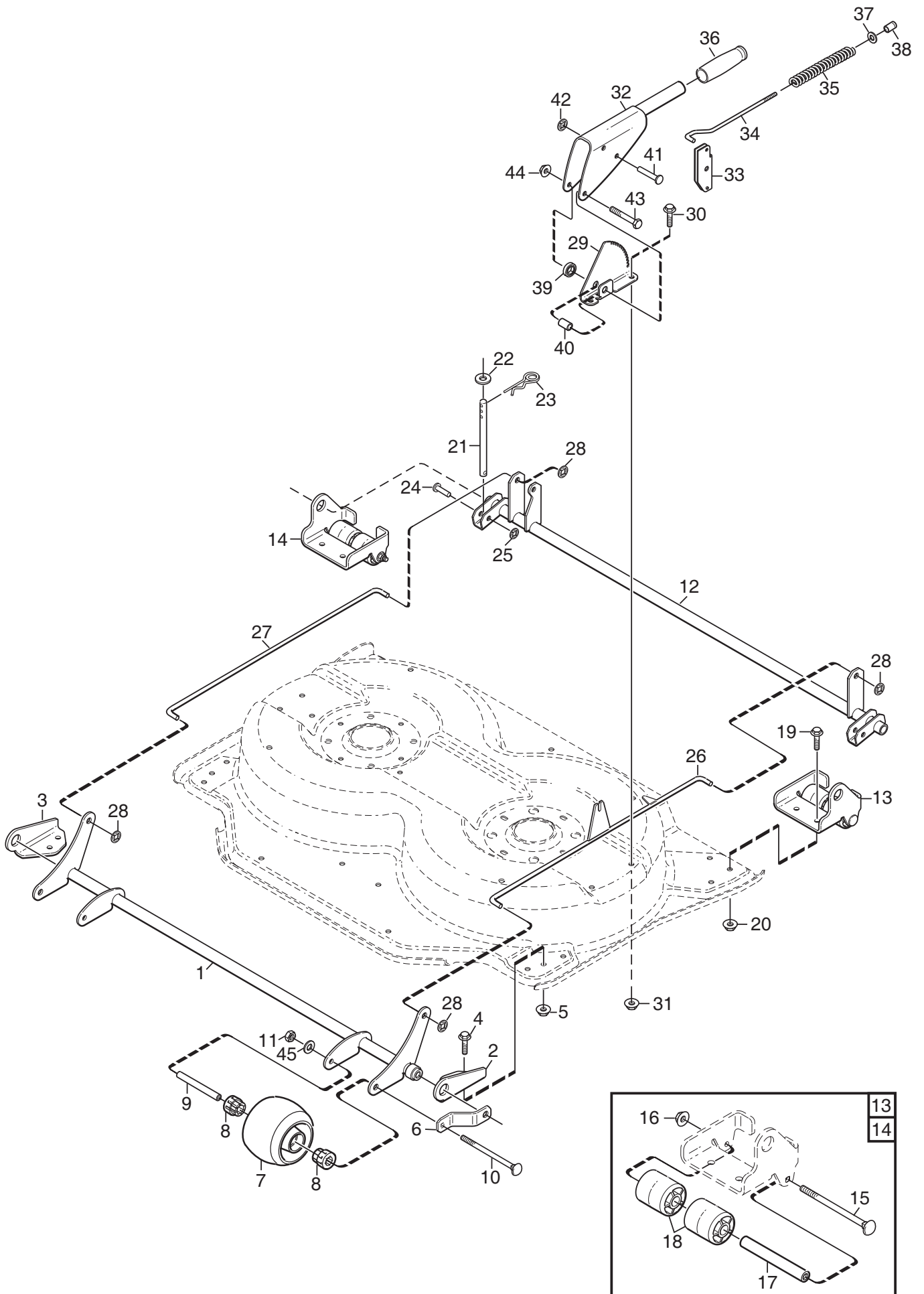

M320

Issue Ausgabe 2008-21		Picture No Bild Nr M320		2105M- 2125H MOWER DECK 85 COMBI CONTROLS		2105M- 2125H MÄHWERK 85 COMBI REGULIERUNGEN		Page Seite 60	
Fig. Pos.	Quantity/Anzahl				Part No. Artikel Nr.	Description	Bezeichnung	Kit Satz	Notes Anmerkung
	2960 -92								
1	1				1134-6275-02	Front axle- black	Vorderachse- schwarz		
2	1				1134-6214-03	Bracket fr- LH, black	Halter- L, schwarz		
3	1				1134-6214-04	Bracket fr- RH, black	Halter- R, schwarz		
4	4				9959-0816-16	Screw	Schraube		
5	4				9739-0831-22	Nut	Mutter		
6	2				1134-6278-02	Guide- black	Leitblech- schwarz		
7	2				1134-4284-01	Wheel	Rad		
8	4				1134-4319-01	Bearing	Lager		
9	2				1134-4318-01	Wheel axle	Radachse		
10	2				9897-0813-22	Screw	Schraube		
11	2				9747-0831-02	Lock nut	Mutter		
12	1				1134-6197-02	Rear axle- black	Hinterachse- schwarz		
13	1				1134-6282-01	Roller- LH, w/bracket	Rollen- L, m.Halter		Pos 15 - 18 incl.
14	1				1134-6282-02	Roller- RH, w/bracket	Rollen- R, m.Halter		Pos 15 - 18 incl.
15	1				9897-0813-02	• Screw	• Schraube		
16	1				9739-0831-22	• Nut	• Mutter		
17	1				1134-4318-01	• Wheel axle	• Radachse		
18	2				1134-6206-01	• Roller	• Rollen		
19	4				9959-0816-16	Screw	Schraube		
20	4				9739-0831-22	Nut	Mutter		
21	2				1134-6198-01	Stud	Stange		
22	2				9699-0104-02	Washer	Scheibe		
23	2				9598-2001-02	Spring pin	Schließnadel		
24	2				9646-0098-22	Rivet	Niet		
25	2				9675-0012-02	Locking washer	Verriegelungsscheibe		
26	1				1134-6249-03	Push rod- LH	Druckstange- L		
27	1				1134-6246-03	Push rod- RH	Druckstange- R		
28	4				9675-0015-02	Lock washer	Verriegelungsscheibe		
29	1				1134-6255-01	Height adj. quadrant	Höhenverstellsektor		
30	2				9959-0816-16	Screw	Schraube		
31	2				9739-0831-22	Nut	Mutter		
32	1				1134-6244-02	Height adj.lever- bl	Höhenverst.hebel- schw		
33	1				1134-6254-01	Catch	Sperre		
34	1				1134-5444-01	Push rod	Druckstange		
35	1				1134-5445-01	Spring	Feder		
36	1				1134-5503-01	Handle	Griff		
37	1				9699-0087-02	Flat washer	Scheibe		
38	1				1134-3051-01	Locking knob	Sperrknopf		
39	1				1134-6286-03	Spacer	Distanz		
40	1				1134-1565-16	Spacer	Distanz		
41	2				9646-0105-22	Rivet	Niet		
42	2				9672-0006-02	Lock washer	Verriegelungsscheibe		
43	1				9997-0850-16	Screw	Schraube		
44	1				9747-0831-02	Lock nut	Mutter		
45	2				9699-0028-02	Flat washer	Scheibe		

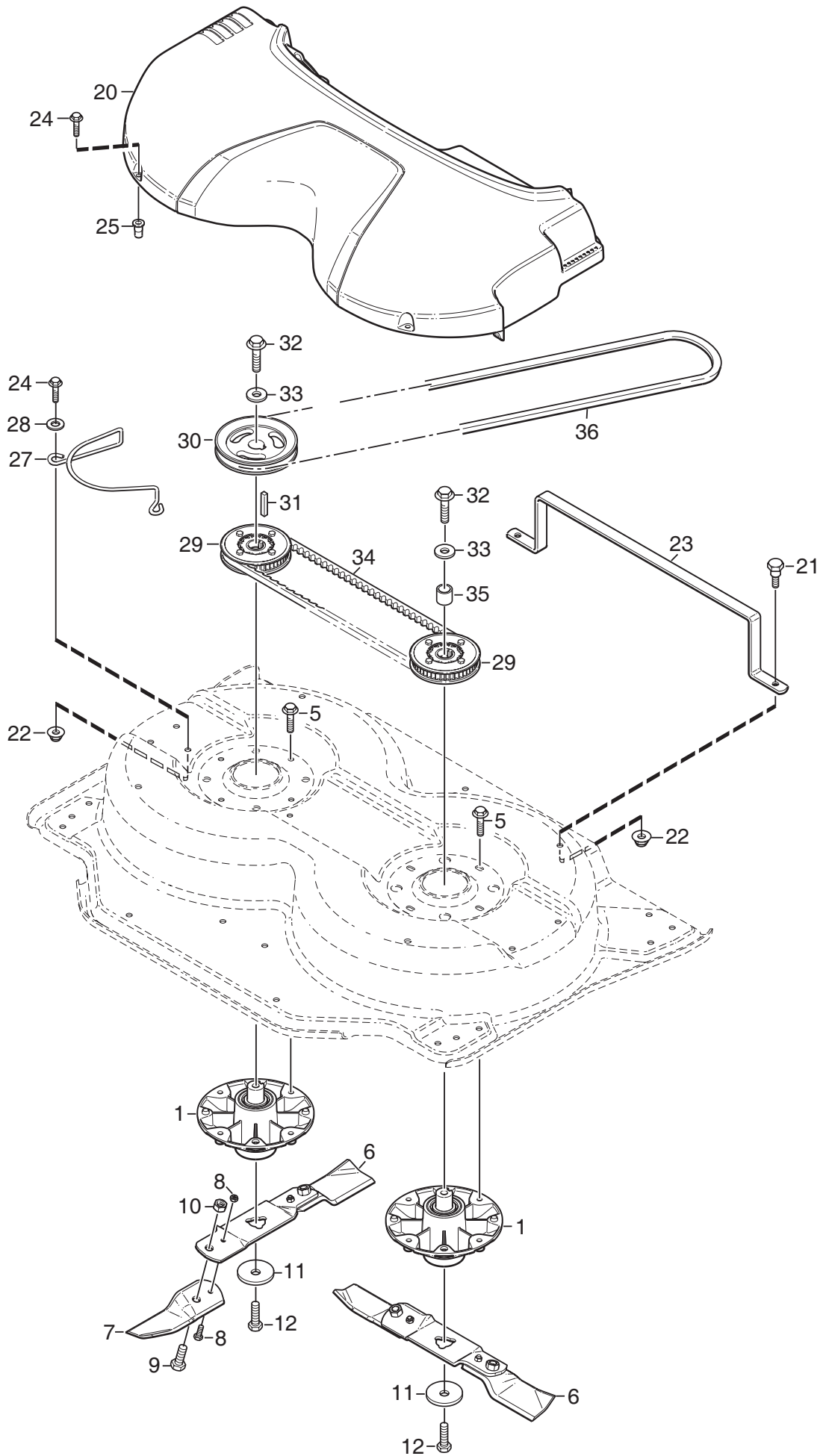

Issue Ausgabe 2008- 21		Picture No Bild Nr M321		2105M- 2125H MOWER DECK 85 COMBI TRANSMISSION		2105M- 2125H MÄHWERK 85 COMBI TRANSMISSION		Page Seite 62	
Fig. Pos.	Quantity/Anzahl				Part No. Artikel Nr.	Description	Bezeichnung	Kit Satz	Notes Anmerkung
	2960 -92								
1	2				1134-5831-01	Bearing box assy	Lagerbuchse kpl.....		
5	8				9945-0825-16	Screw	Schraube.....		
6	2				1134-6240-01	Blade bar assy	Messer kpl		Pos 7 incl.
7	1				1134-9119-01	• Blade kit.....	• Messersatz		Pos 8 - 10 incl.
8	1				1134-9054-01	•• Shear bolt kit	•• Scherbolzensatz		
9	2				1134-6311-01	•• Bolt	•• Bolt.....		7/16" UNF
10	2				1134-6312-01	•• Lock nut.....	•• Schloßmutter		7/16" UNF
11	2				1134-6211-01	Blade washer	Messerscheibe		
12	2				9997-1060-12	Screw	Schraube.....		
20	1				1134-6280-02	Transm.cover- black	Deckel- schwarz		
21	2				1134-0240-01	Shoulder screw.....	Schulter-schraube		
22	4				9739-0831-22	Nut.....	Mutter		
23	1				1134-6423-01	Bracket	Bügel.....		
24	4				9945-0825-16	Screw	Schraube.....		
25	2				1134-5595-01	Riveting nut	Nietmutter		
27	1				1134-6429-01	Belt guide	Riemenführung		
28	2				9699-0090-02	Flat washer	Scheibe		
29	2				1134-6287-01	Toothed belt pulley	Zahnriemenscheibe		
30	1				1134-6201-01	Belt pulley.....	Riemenscheibe.....		Ø = 154 mm
31	1				9600-0168-01	Key	Keil.....		
32	2				9997-1060-12	Screw	Schraube.....		
33	2				1134-5406-01	Washer	Scheibe		
34	1				9585-0161-01	Toothed belt.....	Zahnriemen		
35	1				1134-5400-04	Spacer	Distanz		
36	1				9585-0154-01	V- belt	Keilriemen		

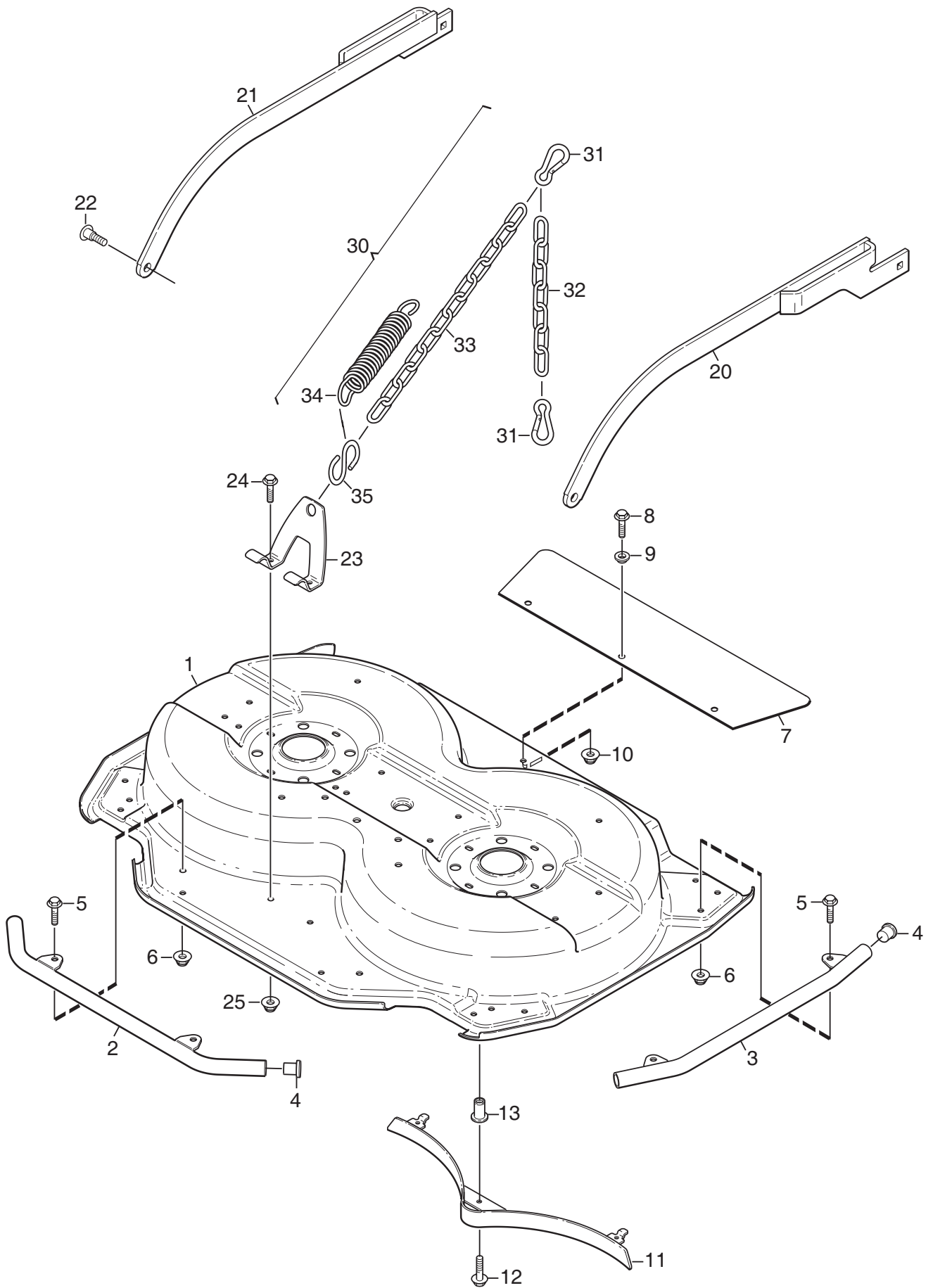

M322

Issue Ausgabe 2008-21		Picture No Bild Nr M322		2105M- 2125H MOWER DECK 95 COMBI FRAME		2105M- 2125H MÄHWERK 95 COMBI RAHMEN		Page Seite 64	
Fig. Pos.	Quantity/Anzahl				Part No. Artikel Nr.	Description	Bezeichnung	Kit Satz	Notes Anmerkung
	2963 -92								
1	1				1134-6190-03	Casing- red	Haube- rot		Pos 13 incl.
2	1				1134-6208-02	Front guard tube- bl.	Frontschutz- schwarz		
3	2				1134-6222-02	Side guard tube- black	Seitenschutz- schwarz		
4	6				9403-0025-70	End cap- black	Propfen- schwarz		
5	6				9959-0816-16	Screw	Schraube		
6	6				9739-0831-22	Nut	Mutter		
7	1				1134-6281-02	Rubber guard	Gummischutz		
8	3				9959-0816-16	Screw	Schraube		
9	3				1134-4185-01	Flange washer	Flanschscheibe		
10	3				9739-0831-22	Nut	Mutter		
11	1				1134-6229-01	Mulching plug	Mulchpropfen		
12	1				9959-0816-16	Screw	Schraube		
13	1				1134-5595-01	• Riveting nut	• Nietmutter		
20	1				1134-6237-09	Deck arm- LH, black	Mähwerkarm- L, schw		
21	1				1134-6237-10	Deck arm- RH, black	Mähwerkarm- R, schw		
22	2				1134-6279-01	Shoulder bolt	Schulterschraube		
23	1				1134-6315-02	Lift bracket- black	Hebehalter- schw		
24	2				9959-0816-16	Screw	Schraube		
25	2				9739-0831-22	Nut	Mutter		
30	1				1134-6363-01	Lift spring assy	Hebefeder kpl	Pos 31 - 35 incl.	
31	2				1134-5528-01	• Snap hook	• Karabinerhaken		
32	1				1134-6368-02	• Chain	• Kette	7 links	
33	1				1134-6368-03	• Chain	• Kette	12 links	
34	1				1134-5625-01	• Mower deck spring	• Mähwerkfeder		
35	1				1134-4623-01	• S- hook	• S- Haken		
99	1				8211-7060-81	Owner's manual	Bedienungsanleitung	Not ill.	

X

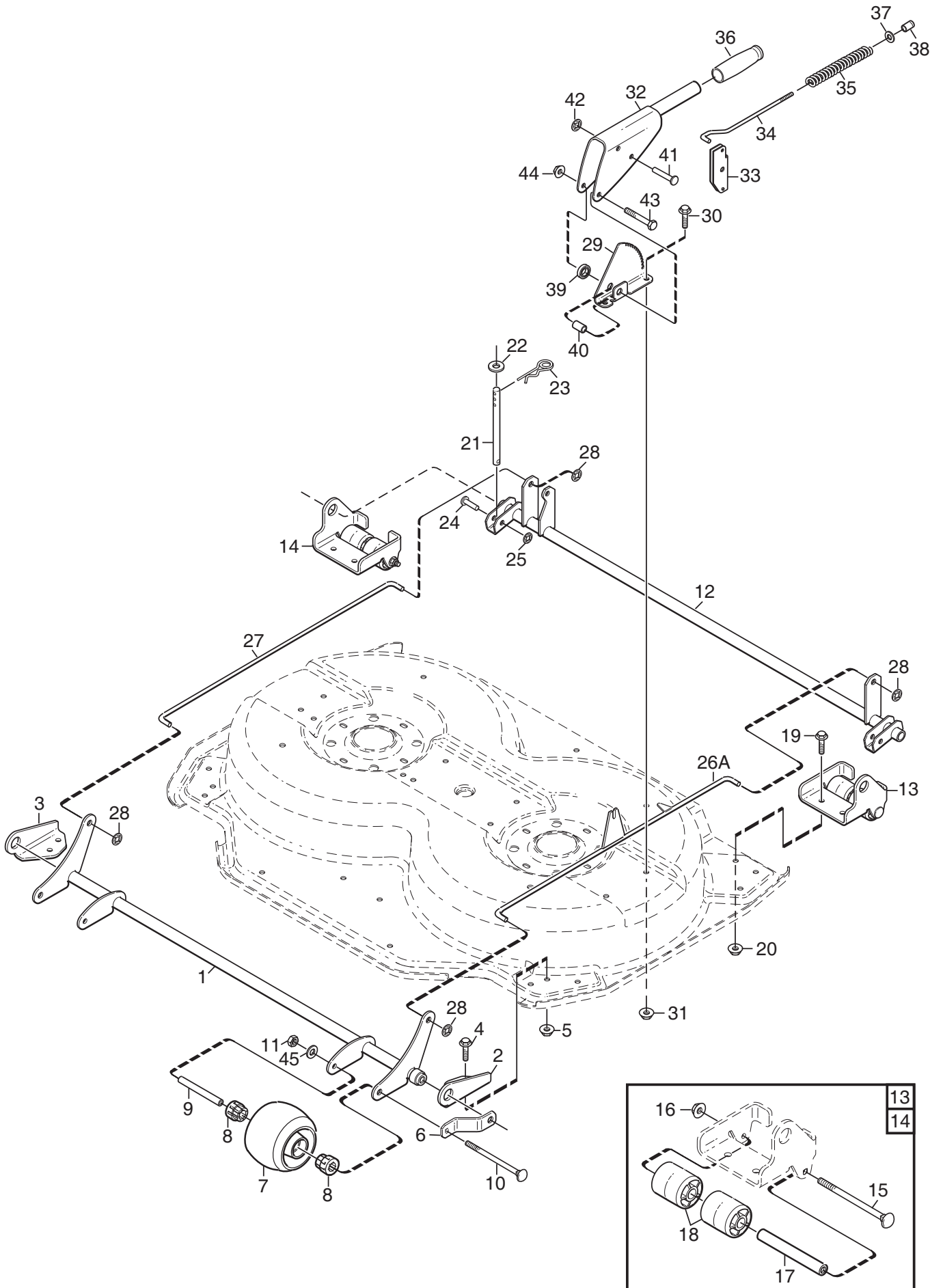

M323

Issue Ausgabe 2008- 21		Picture No Bild Nr M323		2105M- 2125H MOWER DECK 95 COMBI CONTROLS		2105M-2125H MÄHWERK 95 COMBI REGULIERUNGEN		Page Seite 66	
Fig. Pos.	Quantity/Anzahl				Part No. Artikel Nr.	Description	Bezeichnung	Kit Satz	Notes Anmerkung
	2963 -92								
1	1				1134-6275-02	Front axle- black	Vorderachse- schwarz		
2	1				1134-6214-03	Bracket fr- LH, black	Halter- L, schwarz		
3	1				1134-6214-04	Bracket fr- RH, black	Halter- R, schwarz		
4	4				9959-0816-16	Screw	Schraube		
5	4				9739-0831-22	Nut	Mutter		
6	2				1134-6278-02	Guide- black	Leitblech- schwarz		
7	2				1134-4284-01	Wheel	Rad		
8	4				1134-4319-01	Bearing	Lager		
9	2				1134-4318-01	Wheel axle	Radachse		
10	2				9897-0813-22	Screw	Schraube		
11	2				9747-0831-02	Lock nut	Mutter		
12	1				1134-6197-02	Rear axle- black	Hinterachse- schwarz		
13	1				1134-6282-01	Roller- LH, w/bracket	Rollen- L, m.Halter		Pos 15 - 18 incl.
14	1				1134-6282-02	Roller- RH, w/bracket	Rollen- R, m.Halter		Pos 15 - 18 incl.
15	1				9897-0813-02	• Screw	• Schraube		
16	1				9739-0831-22	• Nut	• Mutter		
17	1				1134-4318-01	• Wheel axle	• Radachse		
18	2				1134-6206-01	• Roller	• Rollen		
19	4				9959-0816-16	Screw	Schraube		
20	4				9739-0831-22	Nut	Mutter		
21	2				1134-6198-01	Stud	Stange		
22	2				9699-0104-02	Washer	Scheibe		
23	2				9598-2001-02	Spring pin	Schließnadel		
24	2				9646-0098-22	Rivet	Niet		
25	2				9675-0012-02	Locking washer	Verriegelungsscheibe		
26 A	1				1134-6249-02	Push rod- LH	Druckstange- L		
27	1				1134-6246-02	Push rod- RH	Druckstange- R		
28	4				9675-0015-02	Lock washer	Verriegelungsscheibe		
29	1				1134-6255-01	Height adj. quadrant	Höhenverstellsektor		
30	2				9959-0816-16	Screw	Schraube		
31	2				9739-0831-22	Nut	Mutter		
32	1				1134-6244-02	Height adj.lever- bl	Höhenverst.hebel- schw		
33	1				1134-6254-01	Catch	Sperre		
34	1				1134-5444-01	Push rod	Druckstange		
35	1				1134-5445-01	Spring	Feder		
36	1				1134-5503-01	Handle	Griff		
37	1				9699-0087-02	Flat washer	Scheibe		
38	1				1134-3051-01	Locking knob	Sperrknopf		
39	1				1134-6286-03	Spacer	Distanz		
40	1				1134-1565-16	Spacer	Distanz		
41	2				9646-0105-22	Rivet	Niet		
42	2				9672-0006-02	Lock washer	Verriegelungsscheibe		
43	1				9997-0850-16	Screw	Schraube		
44	1				9747-0831-02	Lock nut	Mutter		
45	2				9699-0028-02	Flat washer	Scheibe		

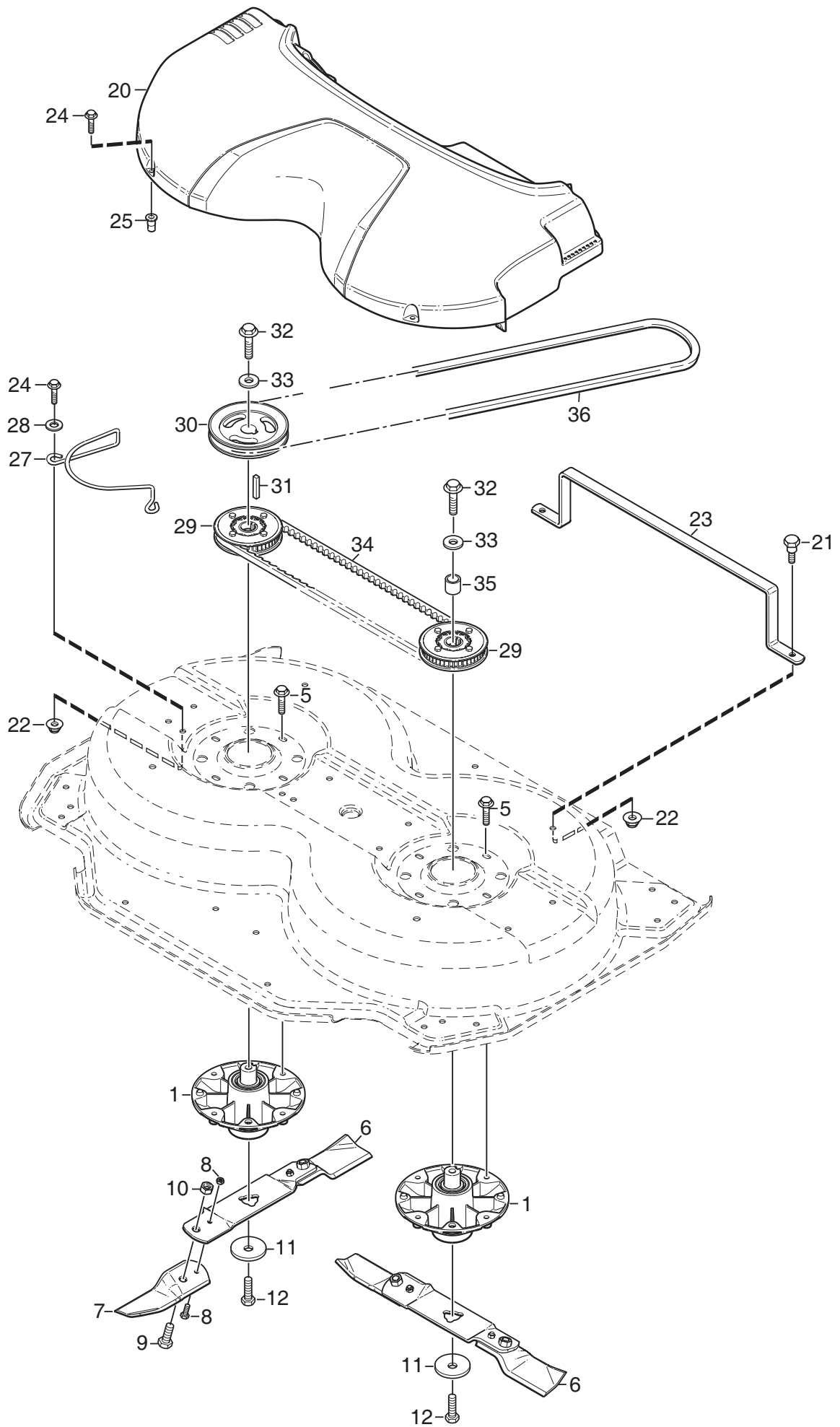

M324

Issue Ausgabe 2008- 21		Picture No Bild Nr M324		2105M- 2125H MOWER DECK 95 COMBI TRANSMISSION		2105M- 2125H MÄHWERK 95 COMBI TRANSMISSION		Page Seite 68	
Fig. Pos.	Quantity/Anzahl				Part No. Artikel Nr.	Description	Bezeichnung	Kit Satz	Notes Anmerkung
	2963 -92								
1	2				1134-5831-01	Bearing box assy	Lagerbuchse kpl.....		
5	8				9945-0825-16	Screw	Schraube.....		
6	2				1134-6240-02	Blade bar assy	Messer kpl		Pos 7 incl.
7	1				1134-9119-01	• Blade kit.....	• Messersatz		Pos 8 - 10 incl.
8	1				1134-9054-01	•• Shear bolt kit	•• Scherbolzensatz		
9	2				1134-6311-01	•• Bolt	•• Bolt.....		7/16" UNF
10	2				1134-6312-01	•• Lock nut.....	•• Schloßmutter		7/16" UNF
11	2				1134-6211-01	Blade washer	Messerscheibe		
12	2				9997-1060-12	Screw	Schraube.....		
20	1				1134-6280-02	Transm.cover- black	Deckel- schwarz		
21	2				1134-0240-01	Shoulder screw.....	Schulter-schraube		
22	4				9739-0831-22	Nut.....	Mutter		
23	1				1134-6423-01	Bracket	Bügel.....		
24	4				9945-0825-16	Screw	Schraube.....		
25	2				1134-5595-01	Riveting nut	Nietmutter		
27	1				1134-6429-01	Belt guide	Riemenführung		
28	2				9699-0090-02	Flat washer	Scheibe		
29	2				1134-6287-01	Toothed belt pulley	Zahnriemenscheibe		
30	1				1134-6202-01	Belt pulley.....	Riemenscheibe.....		Ø = 161 mm
31	1				9600-0168-01	Key	Keil.....		
32	2				9997-1060-12	Screw	Schraube.....		
33	2				1134-5406-01	Washer	Scheibe		
34	1				9585-0162-01	Toothed belt.....	Zahnriemen		
35	1				1134-5400-04	Spacer	Distanz		
36	1				9585-0127-01	V- belt	Keilriemen		