

# LT2119 A

Spare parts

Ersatzteile

Pièces détachées

Reserve onderdelen

Repuestos

Reservdelar

# TRACTOR - MODEL NO. LT2119A (JNA19H48B), PRODUCT NO. 954 13 00-71

## SCHEMATIC

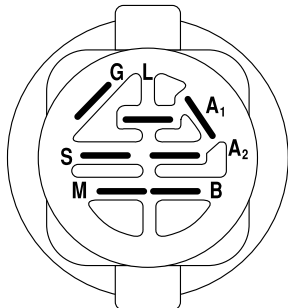
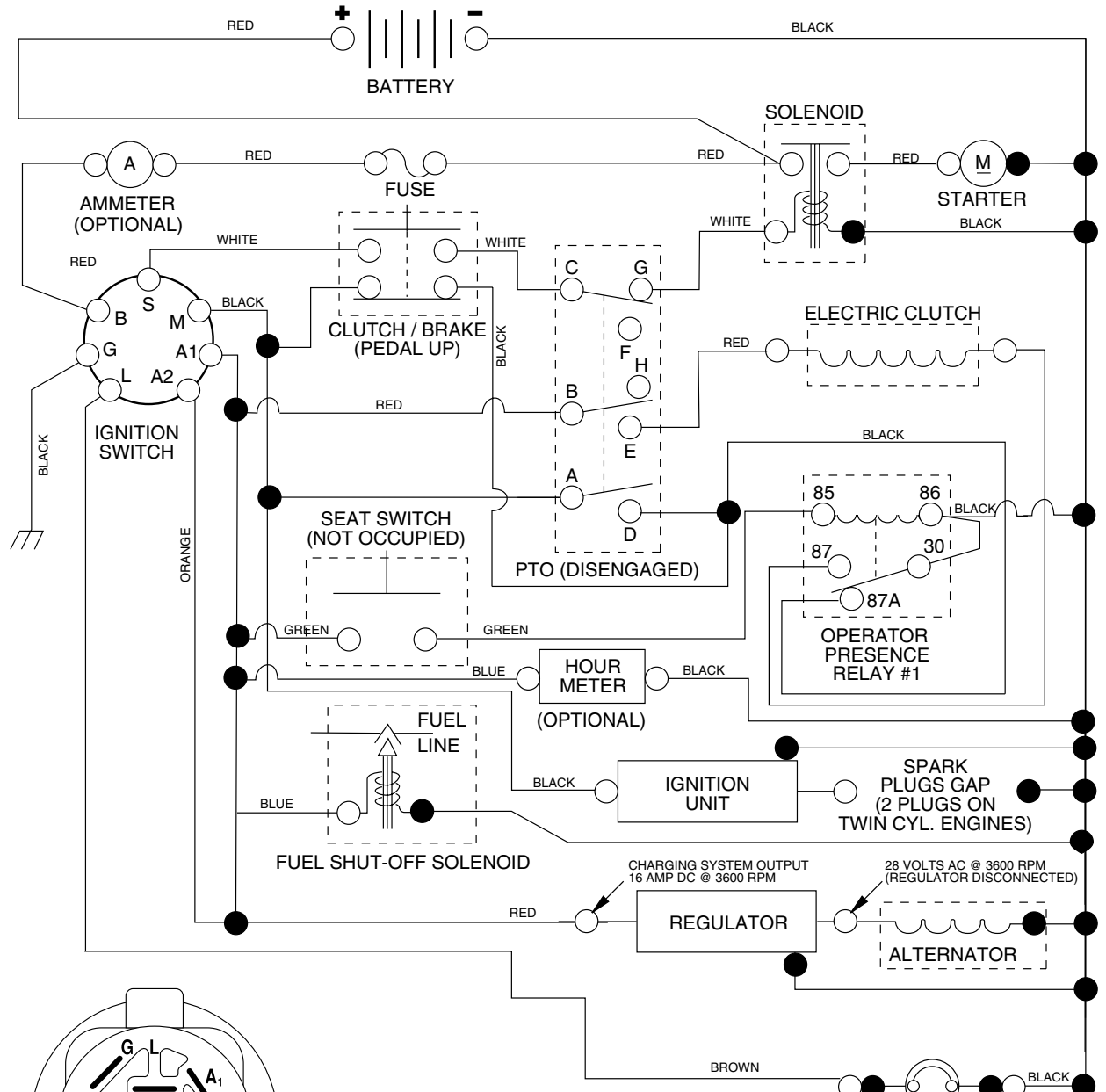

**IGNITION SWITCH**

POSITION	CIRCUIT	"MAKE"
OFF	M+G+A1	NONE
RUN/LIGHT	B+A1	A2+L
RUN	B+A1	NONE
START	B + S + A1	NONE

**WIRING INSULATED CLIPS**

NOTE: IF WIRING INSULATED CLIPS WERE REMOVED FOR SERVICING OF UNIT, THEY SHOULD BE REPLACED TO PROPERLY SECURE YOUR WIRING.

**PTO SWITCH**

POSITION	CIRCUIT
OFF	C + G, B + H
ON	C + F, B + E, A + D

NON-REMOVABLE CONNECTIONS  
 REMOVABLE CONNECTIONS

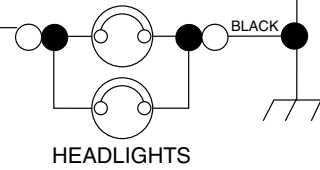
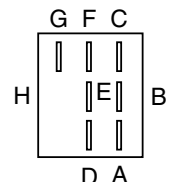
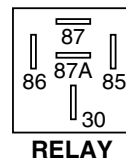

# REPAIR PARTS

TRACTOR - MODEL NO. LT2119A (JNA19H48B), PRODUCT NO. 954 13 00-71  
ELECTRICAL

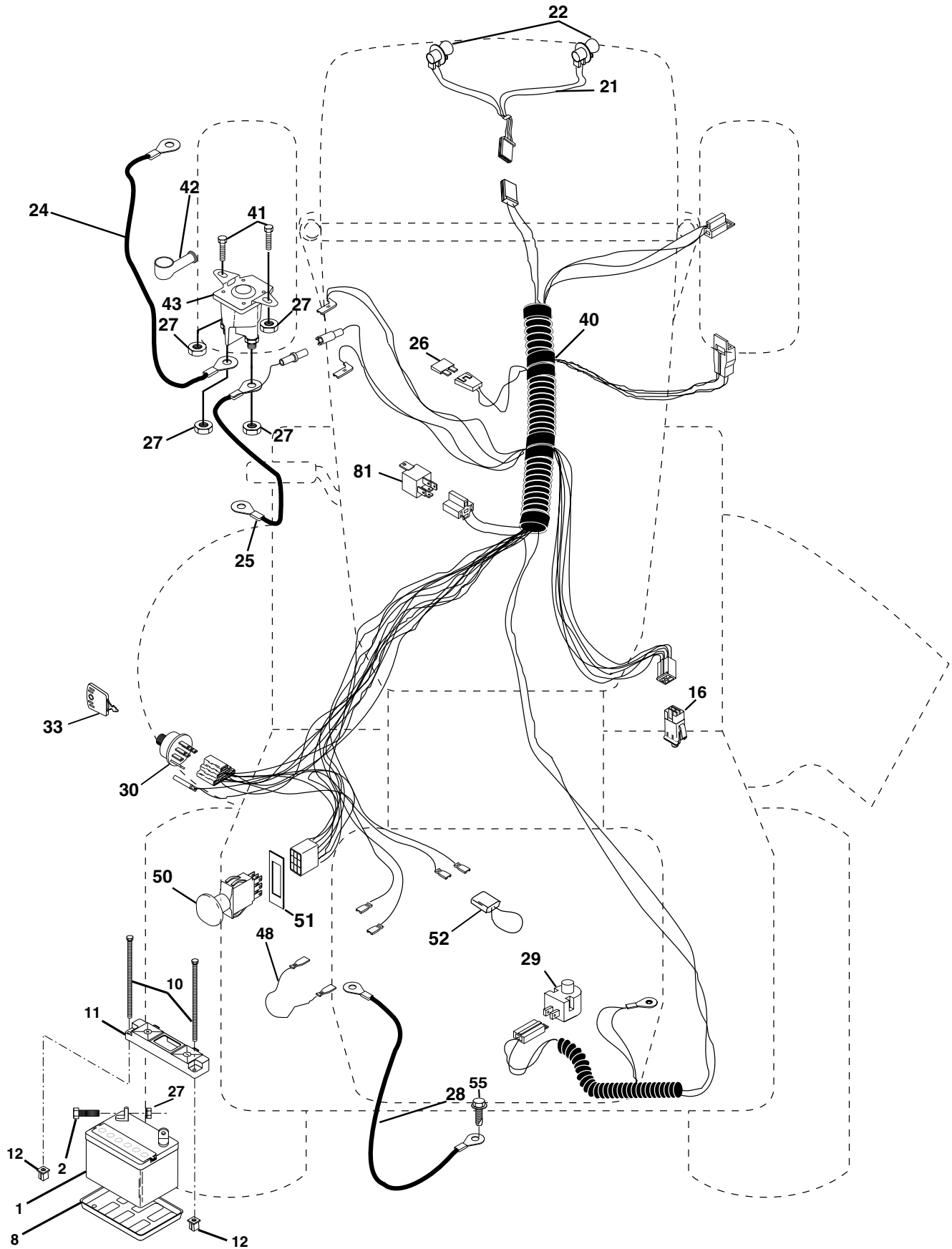

# REPAIR PARTS

TRACTOR - MODEL NO. LT2119A (JNA19H48B), PRODUCT NO. 954 13 00-71  
ELECTRICAL

KEY NO.	PART NO.	DESCRIPTION
1	532 14 49-27	Battery 12 Volt 35 AMP
2	874 76 04-12	Bolt Hex Hd 1/4-20unc X 3/4
8	532 12 48-86	Tray Battery
10	532 14 52-11	Bolt Brt Frt 1/4-20 x 75 Ainc
11	532 15 01-09	Holddown Battery Front Mount
12	532 14 57-69	Nut Push Nylon 1/4" Battery Frt
16	532 17 61-38	Switch Interlock
21	532 17 56-85	Harness Asm Light W/4152j
22	532 00 41-52	Bulb Light #1156
24	532 12 47-80	Cable Battery 6 Ga 11" red
25	532 14 61-48	Cable Battery 6 Ga 22" red w/16 wire
26	532 17 51-58	Fuse
27	873 51 04-00	Nut Keps Hex 1/4-20 Unc
28	532 14 54-91	Cable Ground 6 Ga 21" black
29	532 16 07-84	Switch Plunger Nc Gray
30	532 17 55-66	Switch Ign
33	532 14 04-01	Key Ign Molded Generic
40	<b>532 17 97-24</b>	Harness Ign.
41	871 11 04-08	Bolt Blk Fin Hex 1/4 - 20 x 1/2
42	532 13 15-63	Cover Terminal Red
43	532 17 88-61	Solenoid
48	532 14 08-44	Adapter Ammeter
50	532 17 46-51	Switch PTO
51	532 14 04-05	Ring Retainer
52	532 14 19-40	Protection Wire Loop
55	817 49 05-08	Screw Thdrol 5/16-18 x 1-1/2 Tyt
81	532 10 97-48	Relay Asm.

**NOTE:** All component dimensions given in U.S. inches.  
1 inch = 25.4 mm.

# REPAIR PARTS

TRACTOR - MODEL NO. LT2119A (JNA19H48B), PRODUCT NO. 954 13 00-71  
CHASSIS AND ENCLOSURES

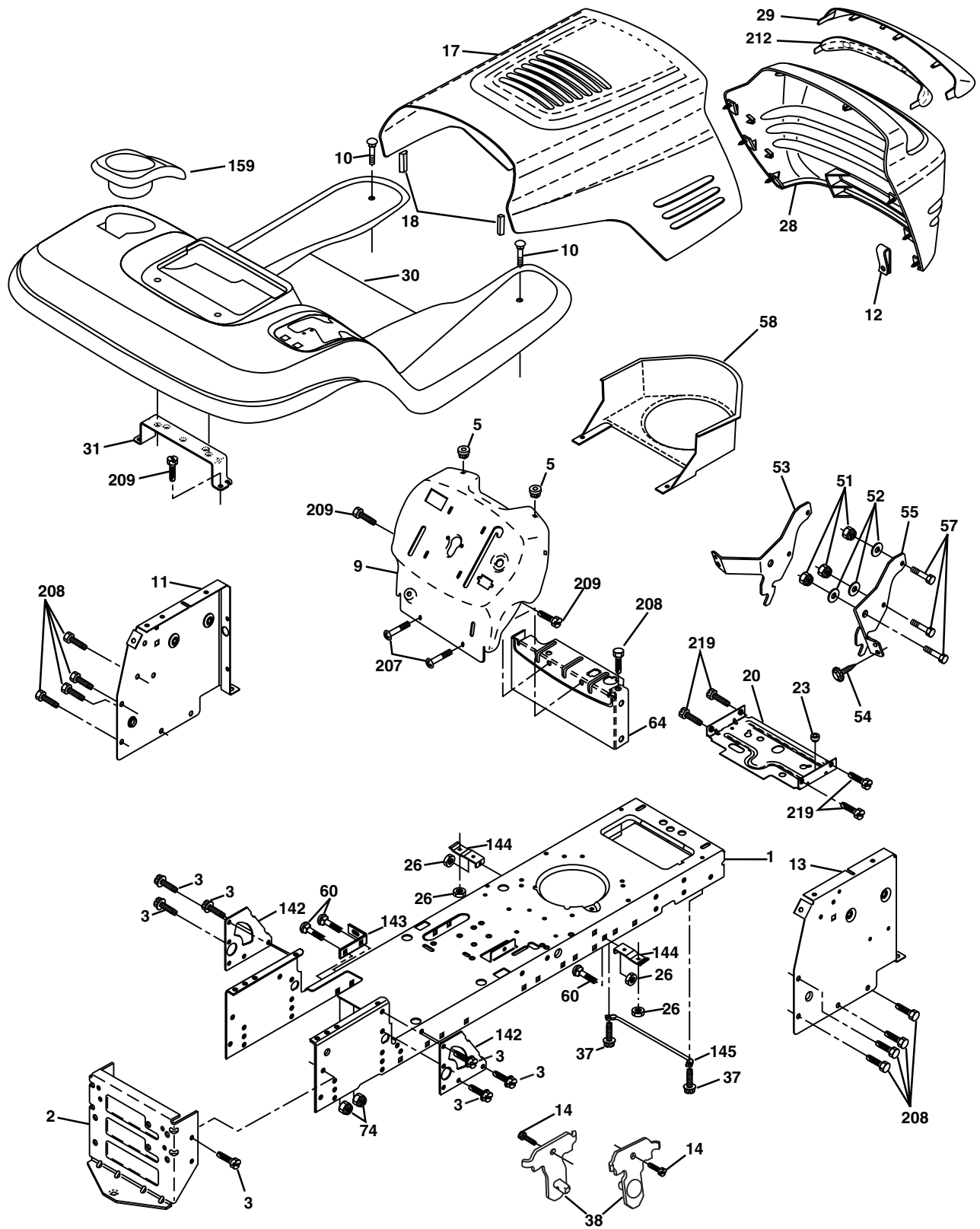

# REPAIR PARTS

TRACTOR - MODEL NO. LT2119A (JNA19H48B), PRODUCT NO. 954 13 00-71  
CHASSIS AND ENCLOSURES

KEY NO.	PART NO.	DESCRIPTION
1	532 17 46-19	Chassis Stamping
2	532 17 65-54	Drawbar
3	817 06 06-12	Screw 3/8-16x3/4
5	532 15 52-72	Bumper
9	532 17 22-94	Dashboard
10	872 14 06-08	Bolt Rdhd Sqnk 3/8-16 Unc x 1
11	532 17 49-96	Panel Dash Lh
12	532 14 56-60	Clip Tinnerman Grille
13	532 17 21-06	Panel Dash Rh
14	817 49 06-08	Screw Thdrol 3/8-16 x 1/2
17	532 16 35-57	Hood
18	<b>532 18 49-21</b>	Bumper
20	532 18 06-79	Plate Mtg Battery/Fuel Tank
23	532 12 40-28	Bushing
26	873 80 06-00	Nut Lock w/Insert 3/8-16 UNC
28	532 17 91-01	Grille Lens Asm
29	532 16 81-54	Lens
30	532 18 13-53	Fender
31	532 13 99-76	Bracket
37	817 49 05-08	Screw Thdrol 5/16-18 x 1/2
38	532 17 57-10	Bracket Asm Pivot Mower Rear
51	873 80 04-00	Nut Lock w/Insert 1/4-20
52	819 09 14-16	Washer 9/32 x 7/8 x 16 Ga.
53	532 14 46-97	Bracket Grille Lh
54	532 16 14-64	Screw Hex Wshd 8-18 x 7/8
55	532 14 46-96	Bracket Grille Rh
57	874 78 04-12	Bolt Fin Hex 1/4-20 Unc x 3/4
58	<b>532 18 44-61</b>	Duct Air
60	872 14 06-06	Bolt RDHD SQNK 3/8-16 x 3/4
64	532 15 47-98	Dash Lower Stit
74	873 68 06-00	Nut Crownlock 3/8-16
142	532 17 57-02	Plate Reinforcement
143	532 15 49-66	Bracket Swaybar Chassis
144	532 17 55-82	Bracket Ft Rest
145	532 15 65-24	Rod Pivot Chassis Hood
159	532 18 13-55	Cupholder YTGT Blk
207	817 67 05-08	Screw Thdrol 5/16-18 x 1/2 TYTT
208	817 67 06-08	Screw Thdrol 3/8-16 x 1/2 Ty-TT
209	<b>817 00 06-12</b>	Screw Hexwsh Thdr 3/8-16 x 3/4
212	532 15 62-29	Insert Lens Reflect
219	817 00 05-12	Screw 5/16-18 x 3/4
--	<b>532 00 54-79</b>	Plug BTN. BLK

**NOTE:** All component dimensions given in U. S. inches.  
1 inch = 25.4 mm



# REPAIR PARTS

TRACTOR - MODEL NO. LT2119A (JNA19H48B), PRODUCT NO. 954 13 00-71  
DRIVE

KEY NO.	PART NO.	DESCRIPTION	KEY NO.	PART NO.	DESCRIPTION
1	-----	Transaxle (Order parts from trans- axle manufacturer) Hydro gear Model <b>336-0510</b>	77	532 12 35-83	Key, Square
6	817 06 05-12	Screw 5/16-18 x 3/4	78	532 12 17-48	Washer 25/32 x 1-5/8 x 16 Ga.
9	<b>532 17 93-34</b>	Clutch Elec	89	532 18 14-53	Console, Shift
15	874 49 05-44	Bolt Hex Flghd 5/16-18 Gr. 5	90	532 12 43-46	Nut Self-Thd Wsh-hd 1/4 Zinc
16	873 80 05-00	Nut Lock Hex W/Ins. 5/16-18 Unc	95	532 18 08-25	Rod Bypass
17	532 12 61-97	Washer 1-1/2 OD x 15/32 ID x .250	96	<b>532 12 47-88</b>	Retainer Spring 1"
19	873 80 06-00	Nut Lock Hex W/Wsh 3/8-16 Unc	116	872 14 06-08	Bolt RDHD SQNK 3/8-16 Unc x 1
20	532 17 39-37	Bolt Hex 7/16-20 x 4 x Gr. 5-1.5	120	873 90 06-00	Nut Lock Flg 3/8-16 Unc
21	<b>532 18 14-54</b>	Knob Custom Control Cruise	150	532 17 54-56	Spacer Retainer
22	532 17 58-96	Rod, Brake	151	819 13 32-10	Washer 13/32 x 2 x 10 Ga.
24	873 35 06-00	Nut, Hex Jam 3/8-16 Unc	202	<b>872 11 06-14</b>	Bolt 3/8-16 x 1-3/4 Gr. 5
25	532 10 68-88	Spring, Brake Rod	212	532 14 52-12	Nut HexFlange Lock
26	819 13 13-16	Washer	214	532 17 47-35	Link Transaxle
27	876 02 04-12	Pin Cotter 1/8 x 3/4 CAD.	215	532 17 56-46	Cover Pedal Forward
28	532 17 57-65	Rod, Parking Brake	217	532 17 94-33	Pedal Reverse
29	532 07 16-73	Cap, Brake, Park	218	532 17 47-13	Arm Control Pedal Reverse
30	532 16 95-92	Bracket, Transaxle	219	532 17 48-39	Bracket Frest Pdl Ctrl. Hyd
32	874 76 05-12	Bolt Hex Hd 5/16-18 Unc x 3/4	220	532 17 47-11	Bracket Mtg. Pedal Control
33	872 14 05-06	Bolt Rdhd Sqnk 5/16-18 Unc x 3/4	221	872 14 06-06	Bolt Rdhd Sqnk 3/8-16 Unc x 3/4
34	532 17 55-78	Shaft, Foot Pedal	222	873 68 07-00	Nut Crownlock 7/16-14 Unc
35	532 12 01-83	Bearing, Nylon	223	532 17 48-40	Washer Nylon 11/16 ID x .060
36	819 21 16-16	Washer	224	532 17 47-36	Pedal Forward
37	532 12 49-63	Pin, Roll	225	532 17 47-12	Arm Control Pedal Forward
38	532 17 91-14	Pulley, Composite, Flat	226	532 17 49-02	Bolt Pivot Spacer
39	874 76 06-48	Bolt Fin Hex 3/8-16 Unc x 3	227	532 17 47-10	Cam Reverse Pedal LT
41	532 17 55-56	Keeper, Belt Idler Flat	228	532 17 90-32	Bolt Shoulder 5/16-18
47	532 12 77-83	Pulley, Idler, V-Groove	229	532 17 64-51	Washer Serrated 5/16 x .75
48	532 15 44-07	Bellcrank Clutch Grnd Drw Stl	231	532 17 45-73	Strap Torque
49	532 12 32-05	Retainer, Belt	232	532 17 55-70	Actuator Cruise Disengage
50	<b>872 11 06-12</b>	Bolt Carr Sh 3/8-16 x 1-1/2 Gr.5	233	532 17 48-56	Pawl Control Cruise
51	873 68 06-00	Nut Crownlock 3/8-16 UNC	234	532 17 48-58	Lever Control Cruise
52	873 68 05-00	Nut, Crownlock 5/16-18 Unc	235	532 17 48-57	Sector Control Cruise
53	532 10 57-10	Link, Clutch	236	532 12 89-03	Bolt Shoulder 3/8-16 Unc 1/44
55	532 10 57-09	Spring, Return, Clutch	237	532 17 01-65	Bolt Shoulder 5/16-18
56	817 06 06-20	Screw 3/8-16 x 1.0	238	532 17 58-07	Arm Mtg. Cruise Sector
57	532 14 02-94	V-Belt, Ground Drive	239	817 49 05-08	Screw Thdrol 5/16 x 1/2
59	532 16 96-91	Keeper, Center Span	240	532 17 56-10	Spring Return Cruise Control
61	817 12 06-14	Screw 3/8-16 x .875	241	873 93 04-00	Nut Centerlock 1/4-20 Unc
62	532 12 48-72	Cover, Pedal	242	874 78 04-12	Bolt Fin Hex 1/4-20 Unc x .75
63	<b>532 17 46-07</b>	Pulley, Engine	243	532 17 82-89	Bracket Anti-Rotation CVX
65	810 04 07-00	Washer	244	532 16 68-80	Screw 5/16-18 x 5/8
66	532 15 47-78	Keeper Belt Engine	250	817 06 06-12	Screw 3/8-16 x .75
74	532 13 70-57	Spacer, Axle	251	<b>817 06 05-16</b>	Screw 5/16-18 x 1
75	532 12 17-49	Washer 25/32 x 1-1/4 x 16 Ga.	253	<b>532 17 94-22</b>	Washer .3125 x .615 x 16 Ga.
76	812 00 00-01	E-Ring	254	532 17 80-62	Clip Retainer

**NOTE:** All component dimensions given in U.S. inches  
1 inch = 25.4 mm



# REPAIR PARTS

TRACTOR - MODEL NO. LT2119A (JNA19H48B), PRODUCT NO. 954 13 00-71  
STEERING ASSEMBLY

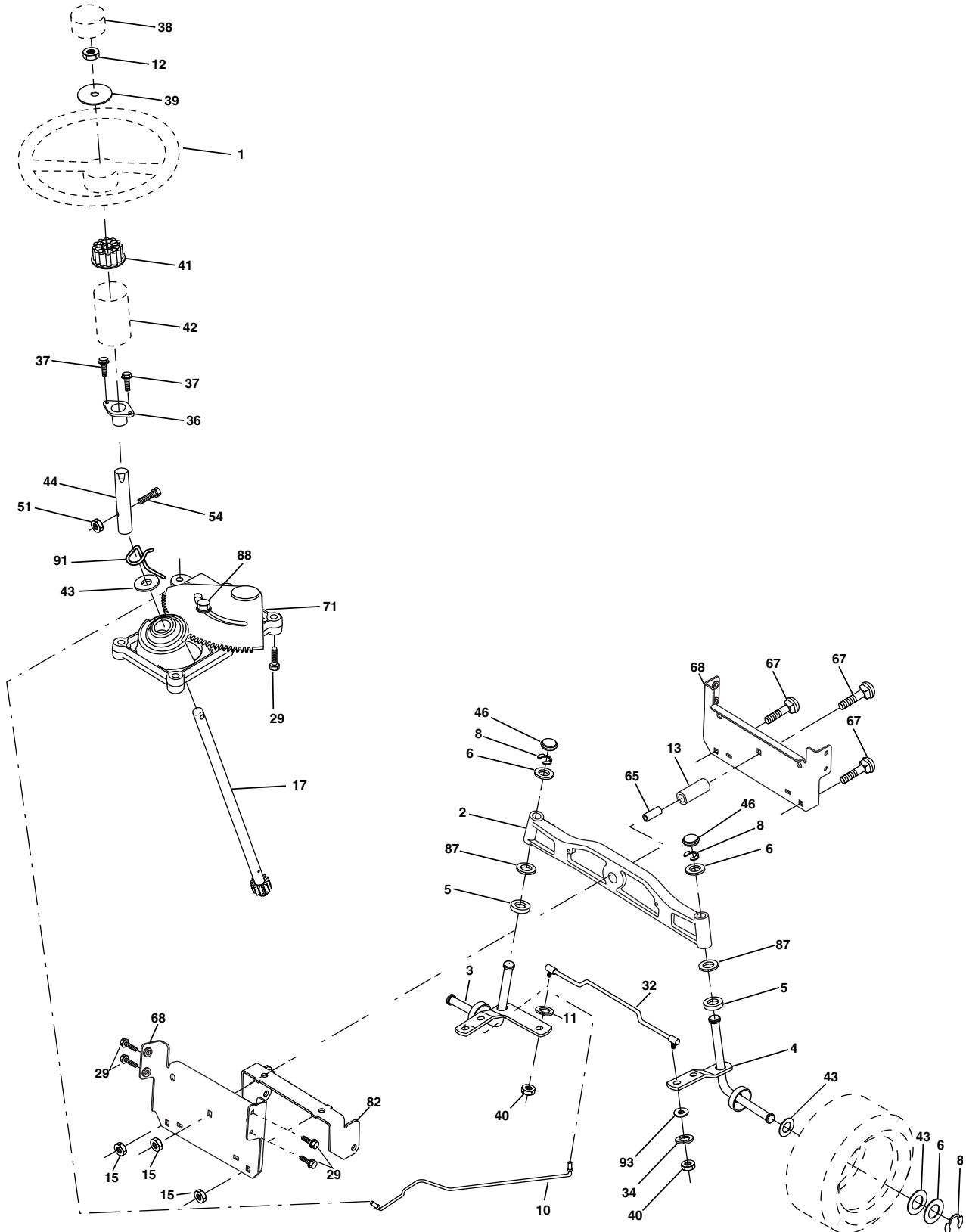

# REPAIR PARTS

TRACTOR - MODEL NO. LT2119A (JNA19H48B), PRODUCT NO. 954 13 00-71  
STEERING ASSEMBLY

KEY NO.	PART NO.	DESCRIPTION
1	532 17 20-92	Wheel Steering
2	<b>532 18 47-06</b>	Axle Cast Lt Machined
3	532 16 98-40	Spindle Asm LH
4	532 16 98-39	Spindle Asm RH
5	532 12 49-31	Bearing Race Thrust Harden
6	532 12 17-48	Washer 25/32 X 1-5/8 X 16 Ga
8	812 00 00-29	Ring Klip #t5304-75
10	532 17 51-21	Link Drag
11	810 04 06-00	Washer Lock Hvy Hlcl Spr 3/8
12	873 94 08-00	Nut Hex Jam Toplock 1/2-20 Unf
13	532 13 65-18	Spacer Brg Axle Front
15	532 14 52-12	Nut Hex Flange Lock
17	532 18 06-41	Shaft Asm Strg
29	817 06 06-12	Screw 3/8-16x3/4
32	<b>532 18 05-80</b>	Rod Tie Ball J
34	<b>810 04 06-00</b>	Washer Lock Hvy Helical 3/8
36	532 15 50-99	Bushing Strg
37	532 15 29-27	Screw
38	532 17 20-93	Insert Cap Strg Wh
39	819 18 24-11	Washer 9/16 x 1-1/2
40	532 12 47-01	Lock nut
41	532 15 99-45	Adaptor Wheel Strg
42	532 16 96-33	Boot Steering Shaft
43	532 12 17-49	Washer 25/32 X 1 1/4 X 16 Ga
44	532 18 06-40	Extension Steering Shaft LR/LT
46	532 12 12-32	Cap Spindle Fr Top Blk
51	873 54 04-00	Nut Crownlock 1/4-28
54	871 13 04-20	Bolt Hex 1/4-28unf x 1-1/4 Gr. 8
65	532 16 03-67	Spacer Brace Axle
67	872 14 06-18	Bolt Rdhd Sq 3/8-16 x 2-1/4
68	532 16 98-27	Axle, Brace
71	532 17 51-46	Steering Asm
82	532 16 98-35	Bracket Susp Chassis Front
87	532 17 39-66	Washer Flat .781 x 1-1/2 x .14
88	532 17 51-18	Bolt Shoulder 7/16-20
91	532 17 55-53	Clip Steering
93	<b>819 12 14-14</b>	Washer 3/8 x 7/8 x 14 Ga.

**NOTE:** All component dimensions given in U.S. inches.  
1 inch = 25.4 mm.

# REPAIR PARTS

TRACTOR - MODEL NO. LT2119A (JNA19H48B), PRODUCT NO. 954 13 00-71  
SEAT ASSEMBLY

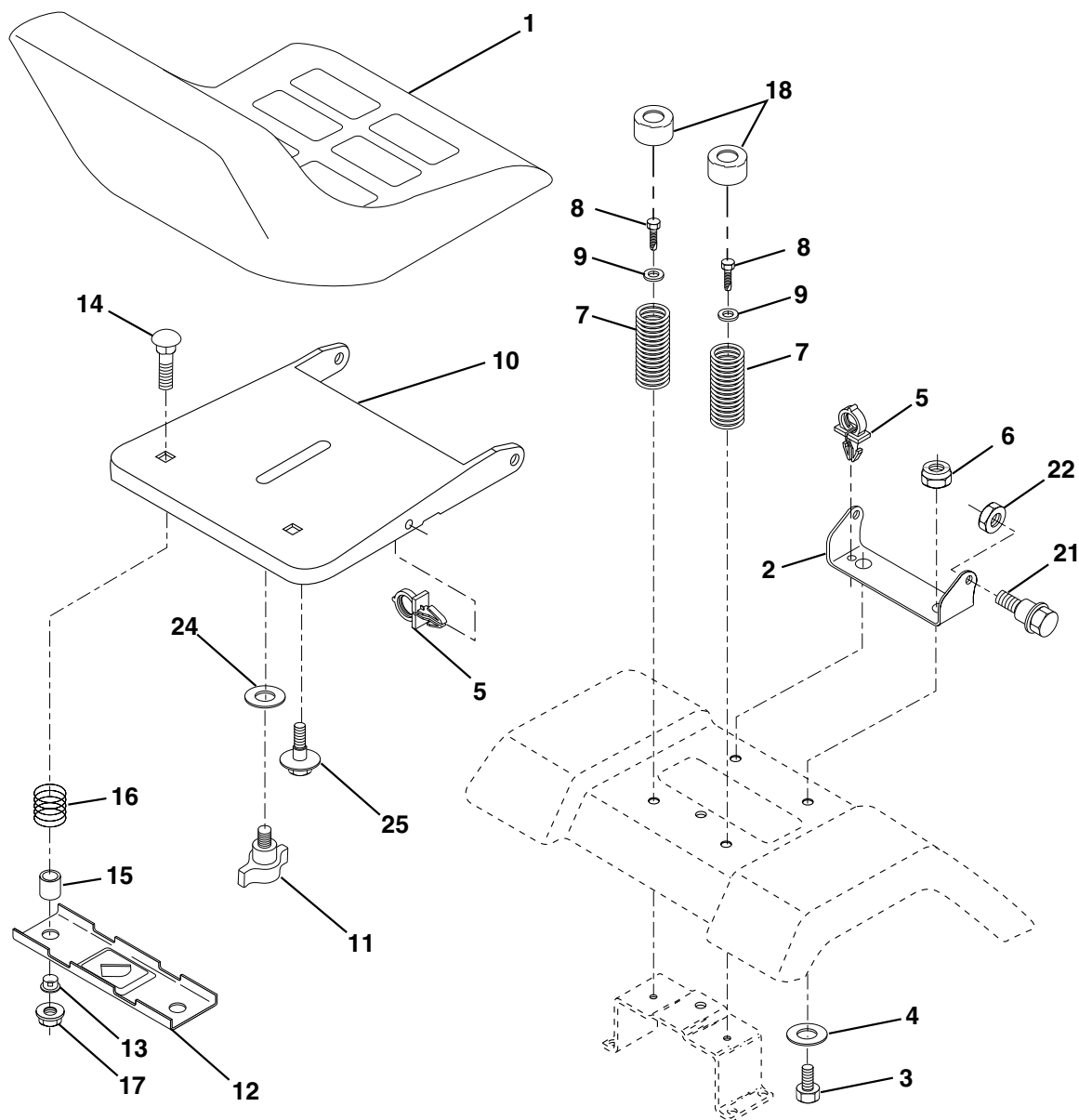

KEY NO.	PART NO.	DESCRIPTION
1	532 14 01-18	Seat
2	532 14 05-51	Bracket Pivot Seat 8 720
3	871 11 06-16	Bolt Fin Hex 3/8-16 x 1
4	819 13 16-10	Washer Flat 13/32 x 1.0 x 10 Ga.
5	532 14 50-06	Clip Push-In
6	873 80 06-00	Nut Hex w/Ins. 3/8-16 Unc
7	532 12 41-81	Spring Seat Cprsn 2 250 Blk Zi
8	817 00 06-16	Screw 3/8-16 x 1
9	819 13 16-14	Washer 13/32 x 1.0 x 14 Ga.
10	532 18 24-93	Pan Seat
11	532 16 63-69	Knob Seat Adj Wingnut
12	532 12 12-46	Bracket Mounting Switch
13	532 12 12-48	Bushing Snap Blk Nyl 50 Id

KEY NO.	PART NO.	DESCRIPTION
14	872 05 04-12	Bolt Rdhd Sqnk 1/4-20x1-1/2
15	532 12 12-49	Spacer Split 28 x .88 Zinc
16	532 12 37-40	Spring Cprsn Plate
17	532 12 39-76	Nut Lock 1/4 Lge Flg Gr 5 Zinc
18	532 12 42-38	Cap Spring Seat
21	532 17 18-52	Bolt Shoulder 5/16-18 Unc
22	873 80 05-00	Nut Hex Lock W/Ins 5/16-18
24	819 17 19-12	Washer 17/32 X 1 -3/16 X 12 Ga.
25	532 12 70-18	Bolt Shoulder 5/16-18 X 62

**NOTE:** All component dimensions given in U.S. inches.  
1 inch = 25.4 mm

# REPAIR PARTS

TRACTOR - MODEL NO. LT2119A (JNA19H48B), PRODUCT NO. 954 13 00-71  
DECALS

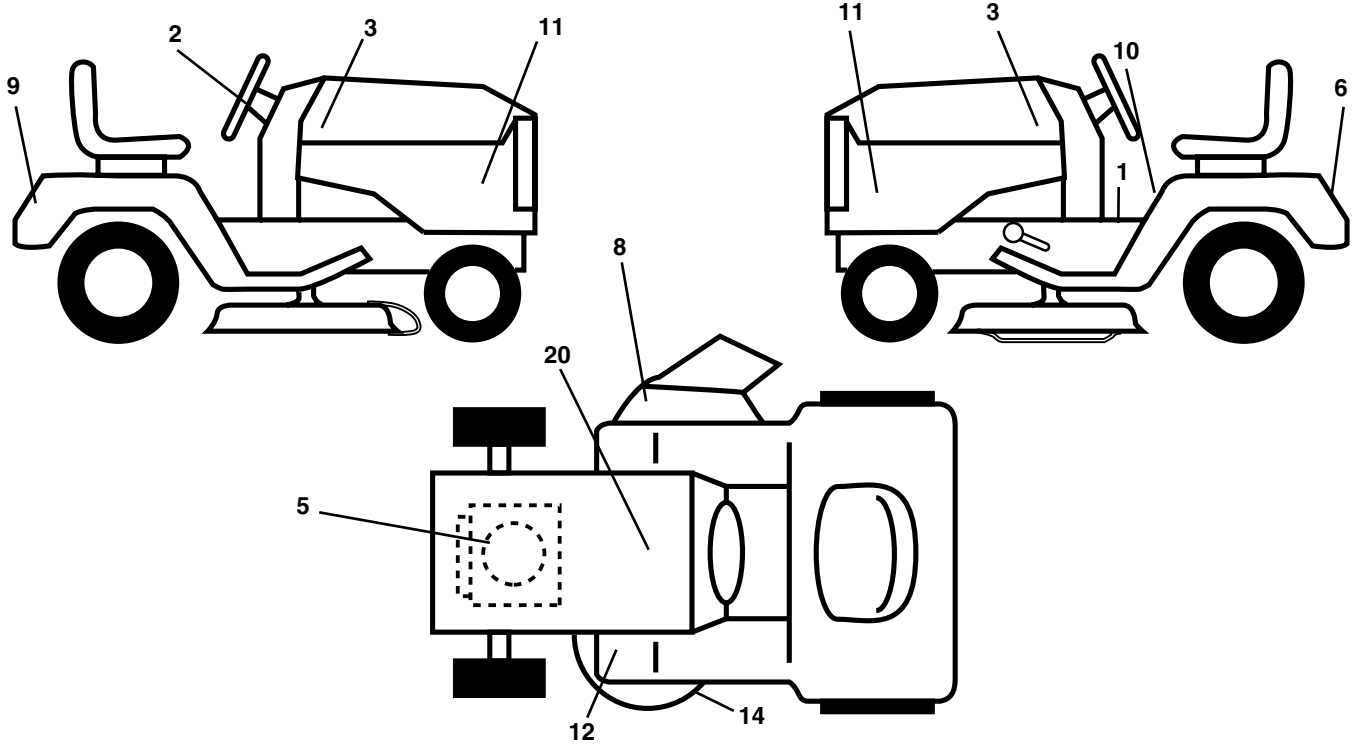

KEY NO.	PART NO.	DESCRIPTION
1	532 17 79-82	Decal Oper Inst Hyd E/F
2	532 18 57-73	Decal Strg Wheel Logo
3	532 18 39-29	Decal Hood RH/LH
5	532 18 07-09	Decal Engine
6	532 18 40-60	Decal Fender
8	532 17 05-63	Decal Warning
9	532 18 39-30	Decal Fender
10	532 15 71-40	Decal Fender Danger E/F
11	532 16 29-27	Decal Hood Sides
12	532 17 85-02	Decal Clutch/Brake

KEY NO.	PART NO.	DESCRIPTION
14	532 17 52-91	Decal V-Belt Schematic
20	532 14 50-05	Decal Bat Dan/Psn
--	532 16 92-10	Decal By Pass Lt Hydro
--	532 18 14-47	Pad Footrest LH
--	532 18-14-48	Pad Footrest RH
--	532 13 83-11	Decal Handle Lft Height Adjust
--	532 18 68-63	Manual Owner's (English)
--	532 18 68-64	Manual Owner's (French)

## WHEELS & TIRES

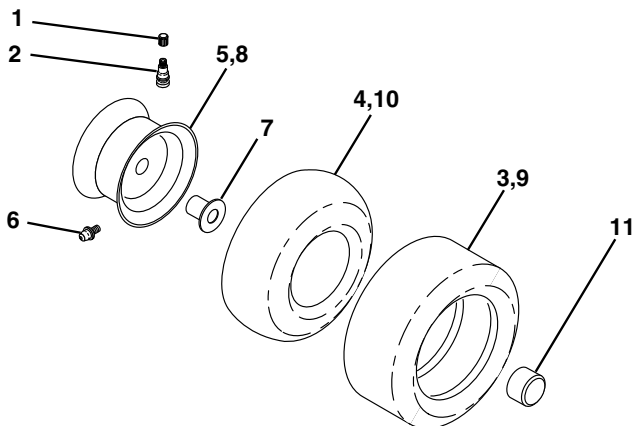

KEY NO.	PART NO.	DESCRIPTION
1	532 05 91-92	Cap Valve Tire
2	532 06 51-39	Stem Valve
3	532 10 62-22	Tire F Ts 15 X 6 0 - 6 Service
4	532 05 99-04	Tube Front (Service Item Only)
5	532 13 83-36	Rim Asm 6"front Silver Service
6	532 12 49-57	Fitting Grease (Front Wheel Only)
7	532 12 49-59	Bearing Flange (Front Wheel Only)
8	532 13 83-37	Rim Asm 8"rear Silver Service
9	532 12 20-82	Tire R Ts 20x10-8 C Service
10	532 12 49-26	Tube Rear (Service Item Only)
11	532 17 50-39	Cap Axle Blk 1 50 X 1 00
--	532 14 43-34	Sealant, Tire ( 10 oz. Tube)

**NOTE:** All component dimensions given in U.S. inches  
1 inch = 25.4 mm

# REPAIR PARTS

TRACTOR - MODEL NO. LT2119A (JNA19H48B), PRODUCT NO. 954 13 00-71  
ENGINE

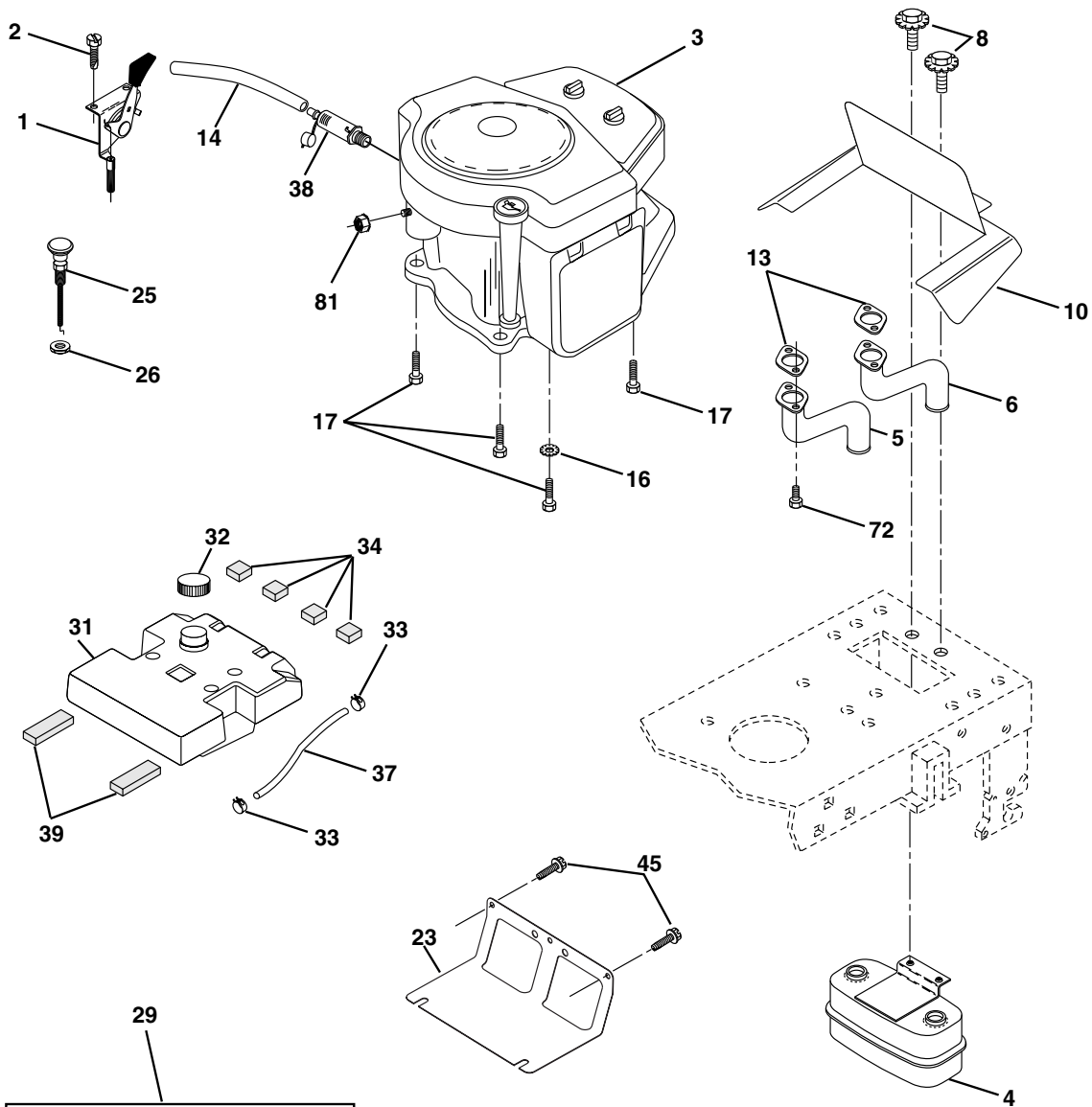

**OPTIONAL EQUIPMENT**  
**Spark Arrester**

engine-bs.twin\_35

# REPAIR PARTS

TRACTOR - MODEL NO. LT2119A (JNA19H48B), PRODUCT NO. 954 13 00-71  
ENGINE

KEY NO.	PART NO.	DESCRIPTION
1	532 17 07-71	Control Throt Flg
2	817 72 04-08	Screw Hex Thd Cut 1/4-20 x 1/2
3	-----	Engine B&S <b>40H777</b> (Order Parts from Engine Manufacturer)
4	532 14 97-23	Muffler Asm Twin Lo-Tone
5	532 16 05-89	Exhaust Tube
6	532 15 99-55	Exhaust Tube
8	532 17 18-77	Bolt 5/16-18unc x 3/4 W/Sems
10	532 16 27-97	Shield Browning
13	532 16 53-91	Gasket Muffler
14	532 14 84-56	Tube Drain Oil Easy
16	811 05 06-00	Washer Lock Ext Tooth 3/8
17	817 06 06-24	Screw 3/8-16 x 1-1/2
23	532 16 98-37	Shield Browning
25	532 14 59-96	Choke Control
26	873 92 06-00	Nut, Keps 3/8-24 Unf
29	532 13 71-80	Kit Spark Arrestor (Flat Scrn)
31	532 15 71-03	Tank Fuel 3 50 Rear
32	532 14 05-27	Cap Asm Fuel
33	532 12 34-87	Clamp Hose Blk
34	532 10 60-82	Pad, Spacer
37	532 14 21-58	Line Fuel
38	<b>532 18 16-54</b>	Plug Drain Oil
39	532 10 92-27	Pad, Idler
45	817 00 06-12	Screw Hexwsh Thdr 3/8-16 x 3/4
72	<b>532 18 39-06</b>	Screw Head Socket 5/16-18 x 1
81	873 51 04-00	Nut Keps Hex 1/4-20 Unc

**NOTE:** All component dimensions given in U.S. inches  
1 inch = 25.4 mm

# REPAIR PARTS

TRACTOR - MODEL NO. LT2119A (JNA19H48B), PRODUCT NO. 954 13 00-71  
MOWER DECK

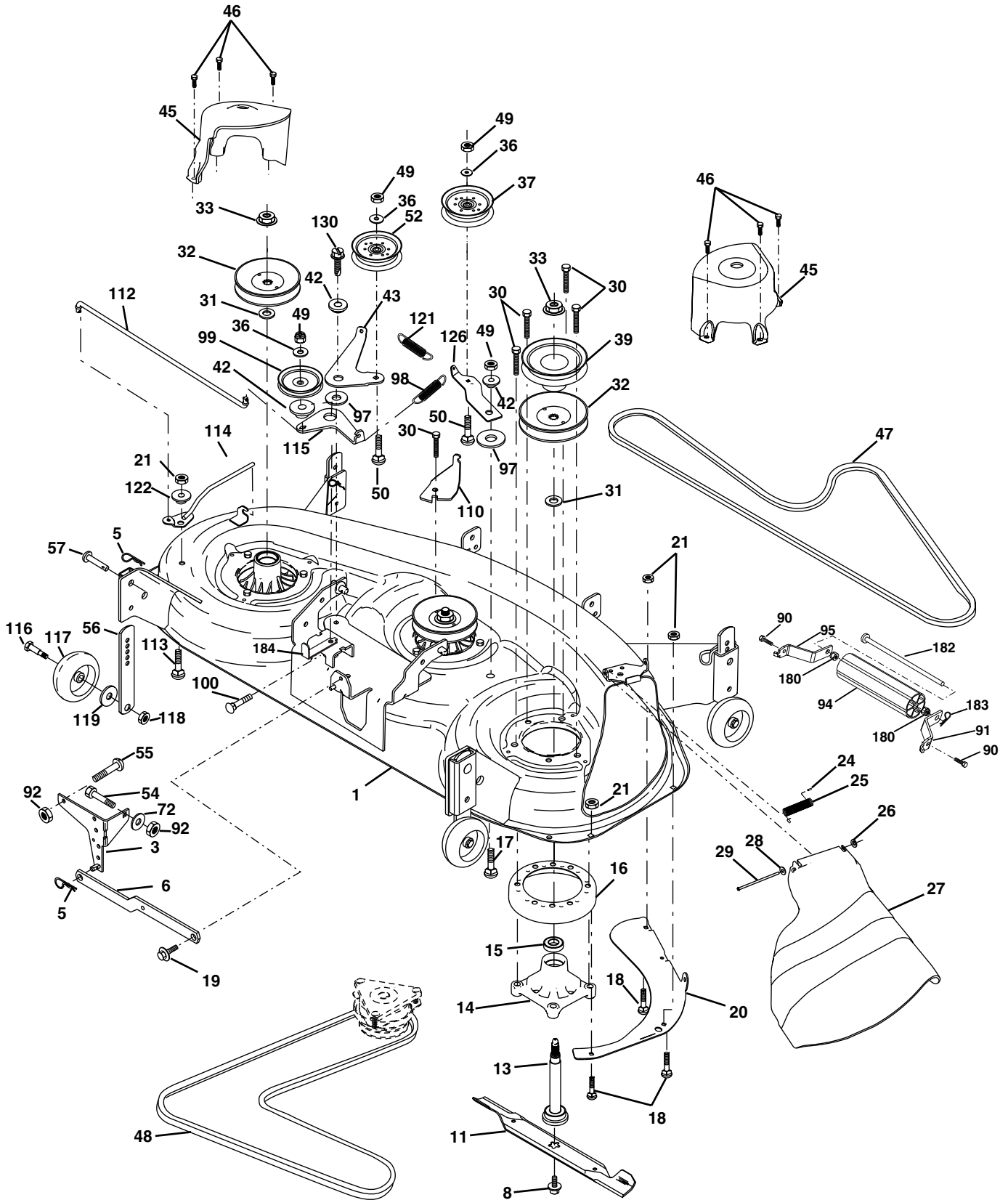

# REPAIR PARTS

**TRACTOR - MODEL NO. LT2119A (JNA19H48B), PRODUCT NO. 954 13 00-71  
MOWER DECK**

KEY NO.	PART NO.	DESCRIPTION	KEY NO.	PART NO.	DESCRIPTION
1	532 18 03-58	Deck Weldment Mower 48	50	872 11 06-12	Bolt, Carriage 3/8-16 x 1-1/2 Gr. 5
3	532 13 80-17	Bracket Asm., Sway Bar	52	532 17 58-20	Pulley Idler Flat 46 Pri. Drive
5	532 12 46-70	Retainer Spring	54	874 78 06-16	Bolt Fin Hex 3/8-16 x 1
6	532 17 80-24	Sway Bar Deck	55	872 14 06-08	Bolt Rdhd Sqnk 3/8-16 x 1
8	532 17 43-65	Bolt, 7/16 Asm. Blade (The following blades are available)	56	532 15 59-86	Bar Pnt Adjusting Wheel Gauge
11	<b>532 17 39-21</b>	Blade, 48" Mulching (For Mulching Mowers Only)	57	532 15 69-41	Pin Head Rivet
11	<b>532 18 00-54</b>	Blade, 48" Hi-Lift (For bagging and discharging)	72	819 13 13-12	Washer 13/32 x 13/16 x 12
13	532 17 43-60	Shaft Asm. greaseable	90	874 76 05-16	Bolt Hex 5/16-18 x 1
14	532 17 43-58	Housing Mandrel 48"	91	532 18 05-34	Bracket, Asm Noseroller, LH 48
15	532 11 04-85	Bearing, Ball, Mandrel	92	873 80 06-00	Nut Lock Hex w/Ins 3/8-16
16	532 17 44-93	Stripper, Mower	94	532 17 60-66	Roller, Nose 48"
17	872 11 06-10	Bolt Rdhd Sq Neck 3/8-16 x 1.25	95	532 18 05-35	Bracket, Asm Noseroller RH 48
18	872 14 05-05	Bolt, Carriage 5/16-18 x 5/8	97	<b>532 17 85-15</b>	Washer Hardened
19	532 13 28-27	Bolt, Hex Head, Shoulder 5/16-18	98	532 17 94-79	Spring Primary Drive
20	532 17 43-78	Baffle, Vortex Mower	99	<b>532 18 40-58</b>	Pulley Idler "V"
21	873 68 05-00	Nut, Crownlock 5/16-18 UNC	100	872 11 06-16	Bolt RDHD Sqnk 3/8-16 Unc x 2
24	532 10 53-04	Cap, Sleeve	110	532 17 50-16	Arm Spring Secondary
25	532 17 81-02	Spring, Torsion	112	532 17 43-87	Link Tension Relief Lever
26	532 11 04-52	Nut, Push	113	<b>872 11 05-06</b>	Bolt 5/16-18 x 3/4
27	532 18 17-07	Shield, Deflector Mower	114	532 17 43-84	Tension Asm Relief Lever
28	819 11 10-16	Washer 11/32 x 5/8 x 16 Ga.	115	532 17 46-09	Arm Spring Tension Relief
29	532 13 14-91	Rod, Hinge	116	<b>532 18 42-19</b>	Bolt, Shoulder
30	532 17 39-84	Screw, Thdroll, Washer Head	117	532 17 48-73	Gauge Wheel
31	532 12 99-63	Washer, Spacer Mower Vented	118	873 93 06-00	Nut, Centerlock 3/8-16 UNC
32	532 17 78-65	Pulley, Mandrel	119	819 12 14-14	Washer 3/8 x 7/8 x 14 Ga.
33	532 17 83-42	Nut, Fig. Top Lock Cntr. 9/16	121	532 17 43-71	Spring Secondary Drive
36	819 13 13-16	Washer 13/32 x 13/16 x 16 Ga.	122	532 17 46-06	Bushing Pivot Tension Relief
37	532 17 79-68	Pulley, Idler, Flat	126	532 17 43-72	Arm, Idler, Primary Deck
39	532 17 43-75	Pulley, Idler, Driven	130	817 00 06-16	Screw 3/8-16 x 1.0
42	532 16 57-23	Spacer, Retainer	180	873 80 05-00	Nut Lock w/Ins. 5/16-18
43	532 17 43-73	Arm, Idler Secondary	182	532 17 91-27	Rod Roller Nose
45	532 18 08-06	Cover, Mandrel Deck	183	532 16 35-52	Retainer Spring
46	532 13 77-29	Screw, Thdroll. 1/4-20 x 5/8	184	532 17 39-79	Keeper Belt Idler
47	532 18 08-08	V-Belt, Mower, Secondary	--	532 18 15-79	Replacement Mower, Complete
48	532 17 43-68	V-Belt, Mower, Primary	--	532 17 43-56	Mandrel Assembly Service (Includes Key Nos. 13-15)
49	873 68 06-00	Nut, Crownlock 3/8-16 UNC			

**NOTE:** All component dimensions given in U.S. inches  
1 inch = 25.4 mm



# REPAIR PARTS

TRACTOR - MODEL NO. LT2119A (JNA19H48B), PRODUCT NO. 954 13 00-71  
MOWER LIFT

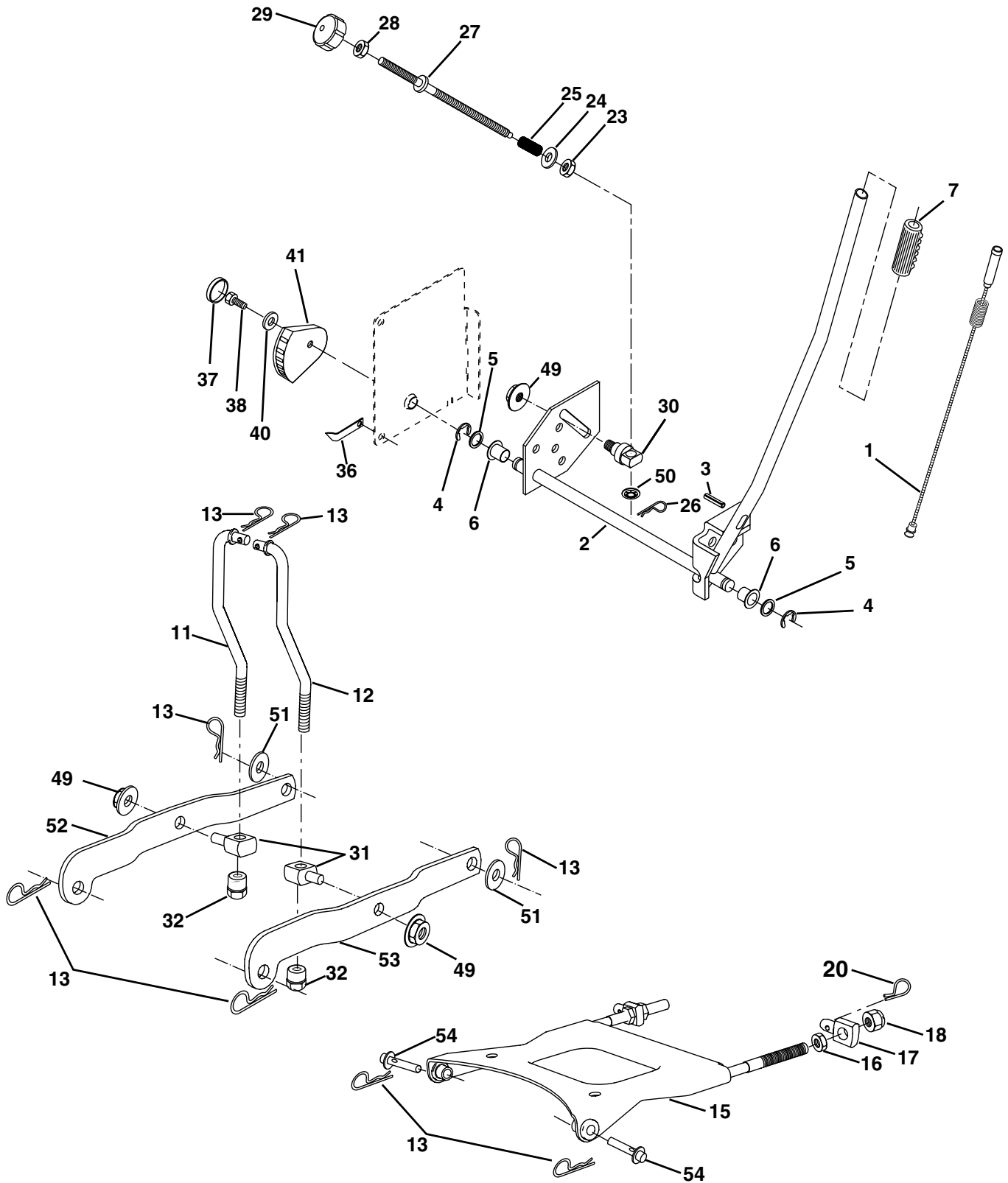

# REPAIR PARTS

TRACTOR - MODEL NO. LT2119A (JNA19H48B), PRODUCT NO. 954 13 00-71  
MOWER LIFT

KEY NO.	PART NO.	DESCRIPTION
1	532 15 94-60	Wire Asm Inner/Spring W/Plunger LT
2	532 15 94-71	Shaft Asm Lift RH w/Inf
3	532 10 57-67	Pin Groove 1 500 Zinc
4	812 00 00-02	E Ring #5133-62
5	819 21 16-21	Washer 21/32 X 1 X 21 Ga
6	532 12 01-83	Bearing Nylon Blk 629 Id
7	532 12 56-31	Grip Handle Fluted Blk
8	532 12 45-26	Button Plunger Black
11	532 17 53-70	Link Lift LH
12	532 17 53-71	Link Lift RH
13	532 12 46-70	Retainer Spring
15	532 17 55-62	Plate Asm Susp Front
16	873 35 08-00	Nut Jam Hex 1/2-13 Unc
17	532 17 56-89	Trunnion
18	873 80 08-00	Nut Lock w/Wsh 1/2-13unc
20	532 16 35-52	Retainer Spring
23	532 11 08-07	Nut Special
24	819 13 10-16	Washer 13/32 X 5/8 X 16 Ga
25	532 12 48-74	Spring 2-1/8"
26	532 16 94-84	Retainer Clip
27	532 12 69-71	Rod Adj Lift Zinc 7.49 Wrk Lg
28	873 35 06-00	Nut Hex Jam 3/8-16 Unc
29	532 13 80-57	Knob Inf 3/8-16 Unc Blk W/sym
30	532 15 02-33	Trunnion Infin Height
31	532 17 62-05	Trunnion
32	532 17 59-94	Nut Lift Link 7/16-20
36	532 15 50-97	Indicator Height STLT
37	532 12 39-35	Plug Hole Blk 1.485/1.515 Dia.
38	817 06 05-16	Screw 5/16-18 x 1
40	819 11 24-10	Washer 11/32 x 1-1/2 10 Ga.
41	532 15 50-98	Scale Ind. Height Blk.
49	532 14 52-12	Nut Hex Flange Lock
50	532 11 04-52	Nut, Push Phos & Oil
51	819 17 14-16	Washer 17/32 x 7/8 x 16 Ga.
52	532 17 53-78	Arm Susp. Rear Lh
53	532 17 58-02	Arm Susp. Rear Rh
54	532 17 55-60	Pin Flange

**NOTE:** All component dimensions given in U.S. inches  
1 inch = 25.4 mm