

# REPAIR PARTS

IMPORTANT INFORMATION

DO NOT THROW AWAY

## LAWN TRACTOR

MODEL NUMBER - LTH13 (HAR13H38B) 954 00 10-42

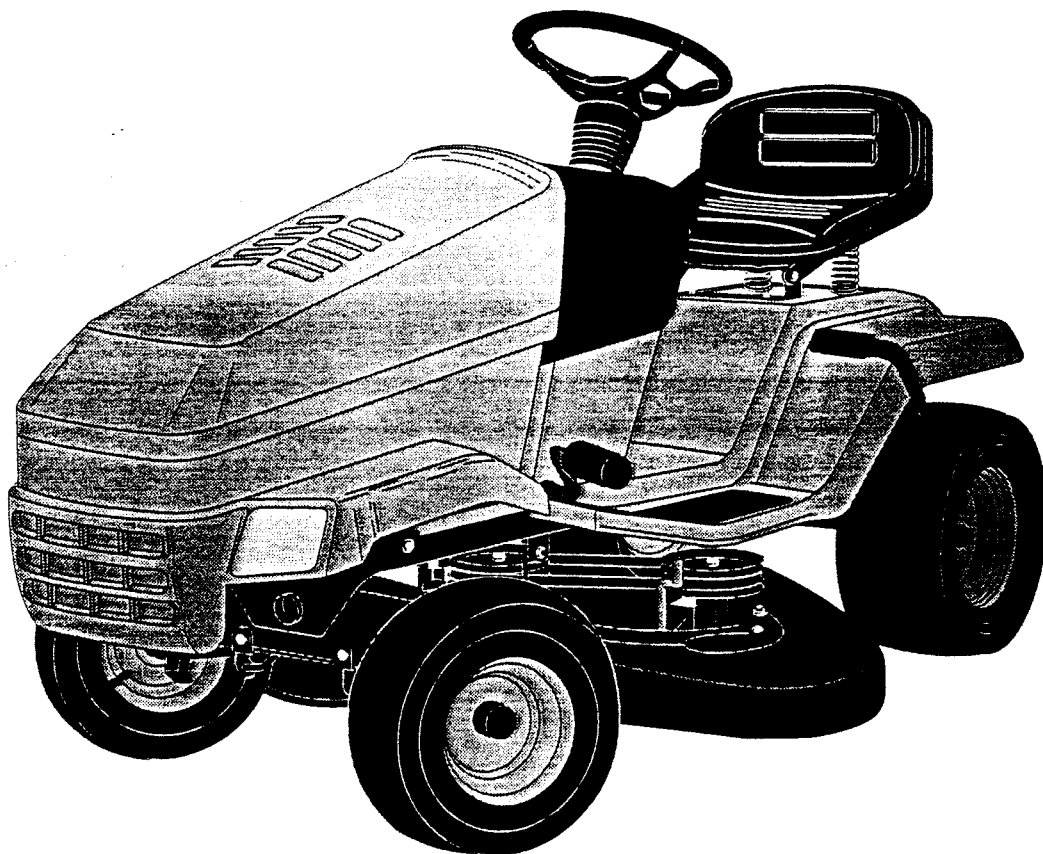

FILE COPY

 **Husqvarna**  
**FOREST & GARDEN**

1995

# HOW TO USE THIS MANUAL

This manual is designed to provide the customer with a means to identify the parts on this product ordering repair parts. The illustrations may or may not represent the actual assemblies; therefore, it is not recommended to use this manual as a guide to assemble or disassemble the product. Some hardware and parts are drawn larger in order to more readily identify them.

Each lawn tractor has its own model number.

The model number for your lawn tractor can be found on the fender under the seat.

When ordering parts, always give the following information:

- Product – "Lawn Tractor"
- Model Number – "LTH13 (HAR13H38B)"
- Part Number
- Part Description

## TABLE OF CONTENTS

<b>BRAKE / REAR MOWER LIFT ASM.....</b>	<b>8</b>
<b>DASH.....</b>	<b>6</b>
<b>DECAL.....</b>	<b>15</b>
<b>ENGINE / THROTTLE.....</b>	<b>11</b>
<b>ELECTRICAL.....</b>	<b>18-19</b>
<b>FENDER / CHASSIS.....</b>	<b>4</b>
<b>FRONT AXLE.....</b>	<b>9</b>
<b>GROUND DRIVE.....</b>	<b>12</b>
<b>HOOD.....</b>	<b>3</b>
<b>MOWER LIFT LEVER.....</b>	<b>14</b>
<b>MOWER DECK.....</b>	<b>16-17</b>
<b>SEAT.....</b>	<b>5</b>
<b>SECTOR GEAR / AXLE SUPPORT.....</b>	<b>10</b>
<b>STEERING WHEEL.....</b>	<b>7</b>
<b>TRANSAXLE.....</b>	<b>13, 20-21</b>

# REPAIR PARTS

TRACTOR-MODEL NO. LTH13 (HAR13H38B), PRODUCT NO. 954 00 10-42

## HOOD

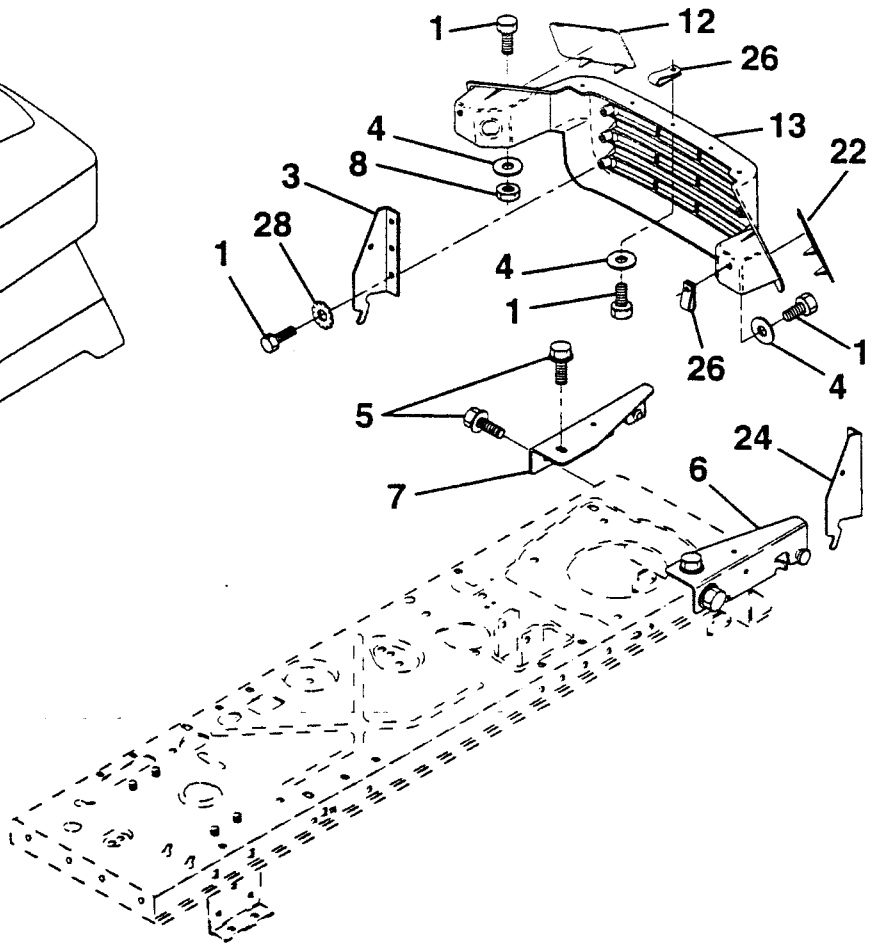
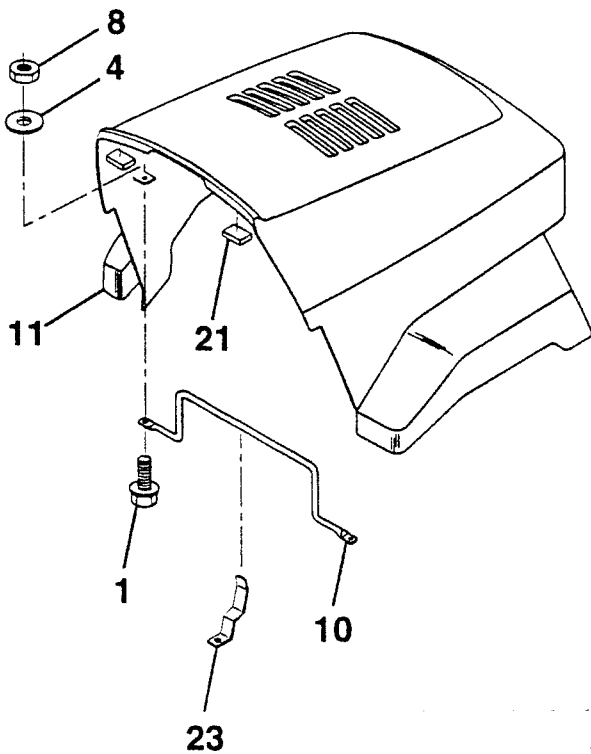

KEY NO.	PART NO.	DESCRIPTION
1	874780410	Bolt Fin Hex 1/4-20 x 5/8
3	532128445	Bracket Pivot Hood LH
4	819091216	Washer 9/32 x 3/4 x 16 Ga.
5	817490512	Screw Thdrol 5/16-18 x 3/4
6	532140051	Bracket Asm. Pivot Hood RH
7	532140050	Bracket Asm. Pivot Hood LH
8	873510400	Nut Keps 1/4-20
10	532130850	Brace Hood
11	532140142	Hood
12	532130986	Lens LH

KEY NO.	PART NO.	DESCRIPTION
13	532130984	Grille
21	532126938	Bumper Hood
22	532130985	Lens RH
23	532139969	Latch Hood
24	532142873	Bracket Pivot Hood RH
26	532052921	Clip Tinnerman
28	811050400	Washer Lock Ext Tooth

**NOTE:** All component dimensions given in U.S. inches  
1 inch = 25.4 mm

HARDWARE SHOWN LARGER FOR EASIER IDENTIFICATION

# REPAIR PARTS

TRACTOR-MODEL NO. LTH13 (HAR13H38B), PRODUCT NO. 954 00 10-42

## FENDER/CHASSIS

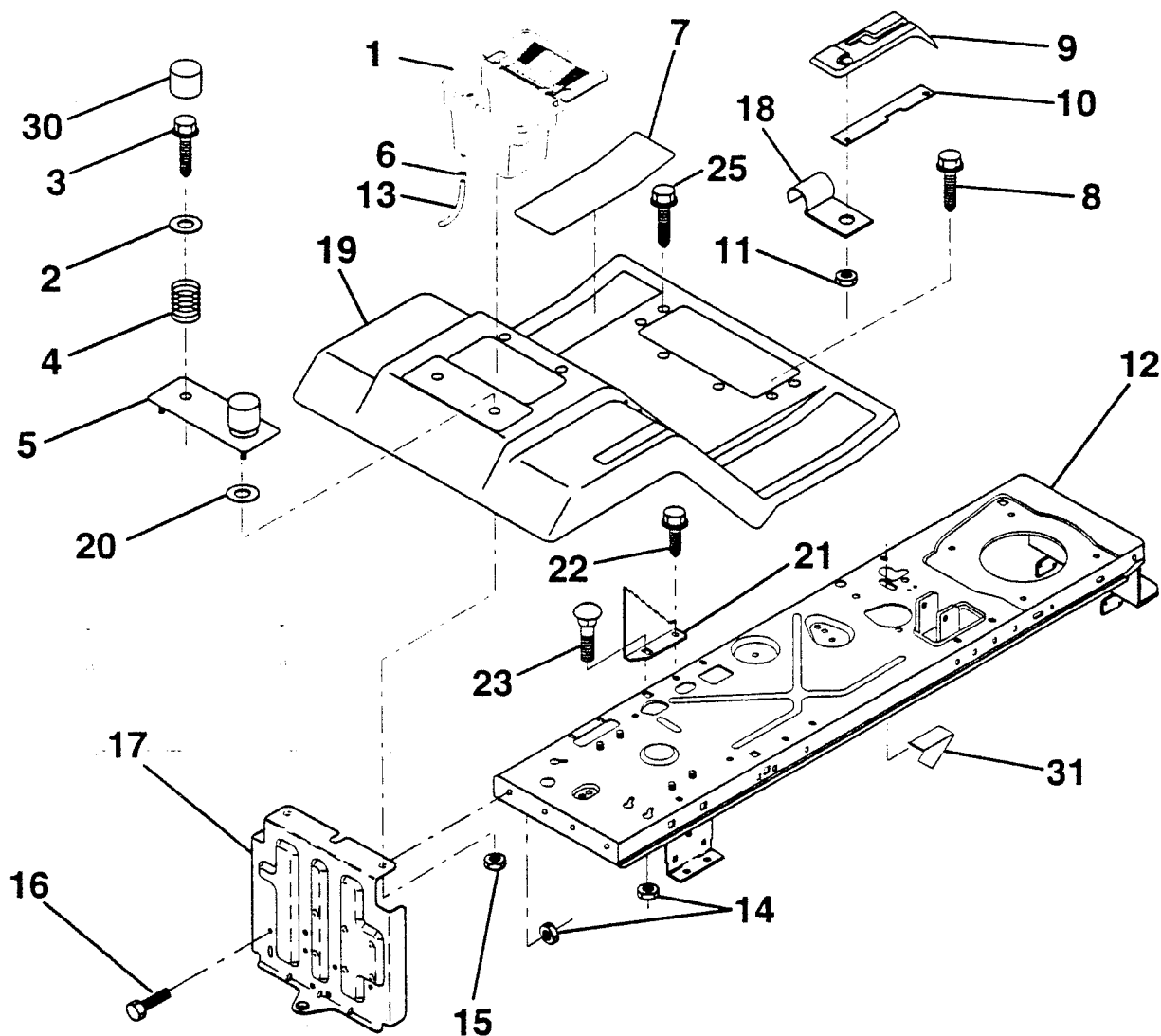

KEY NO.	PART NO.	DESCRIPTION
1	532129965	Case Asm. Battery
2	819132012	Washer 13/32 x 1-1/4 x 12 Ga.
3	817490612	Screw Thdrol. 3/8-16 x 3/4
4	532124181	Spring seat
5	532125142	Plate Asm. Pnt Battery Fender
6	532109596	Clamp Hose Olive
7	532126700	Pad Footrest Rubber Deluxe
8	817490512	Screw Thdrol. 5/16-18 x 3/4
9	532140919	Console Shf. 6sp W/lgn.
11	532124346	Nut Self Thd. Wsh-Hd 1/4
12	532140784	Chassis Asm. Weldment
13	532109238	Tube Plastic
14	873800500	Nut Lock Hex W/Ins. 5/16-18

KEY NO.	PART NO.	DESCRIPTION
15	873510400	Nut Keps Hex 1/4-20
16	874760512	Bolt Hex Hd. 5/16-18 x 3/4
17	532140782	Drawbar Asm.
18	532126470	Clip Insulated
19	532141366	Fend/Foot Asm. Pnt Shf. Fnd.
20	819091413	Washer 9/32 x 7/8 x 13 Ga.
21	532140297	Bracket Stop Depth
22	817490508	Screw Thdrol 5/16-18 x 1/2
23	872110506	Bolt Rdhdsqnk. 5/16-18 x 3/4
25	817490516	Scr-Hex Wsh Rol 5/16-18 x 1
30	532124238	Cap Spring
31	532141736	Switch Actuator

**NOTE:** All component dimensions given in U.S. inches  
1 inch = 25.4 mm

**HARDWARE SHOWN LARGER FOR EASIER IDENTIFICATION**

# REPAIR PARTS

TRACTOR-MODEL NO. LTH13 (HAR13H38B), PRODUCT NO. 954 00 10-42

## SEAT

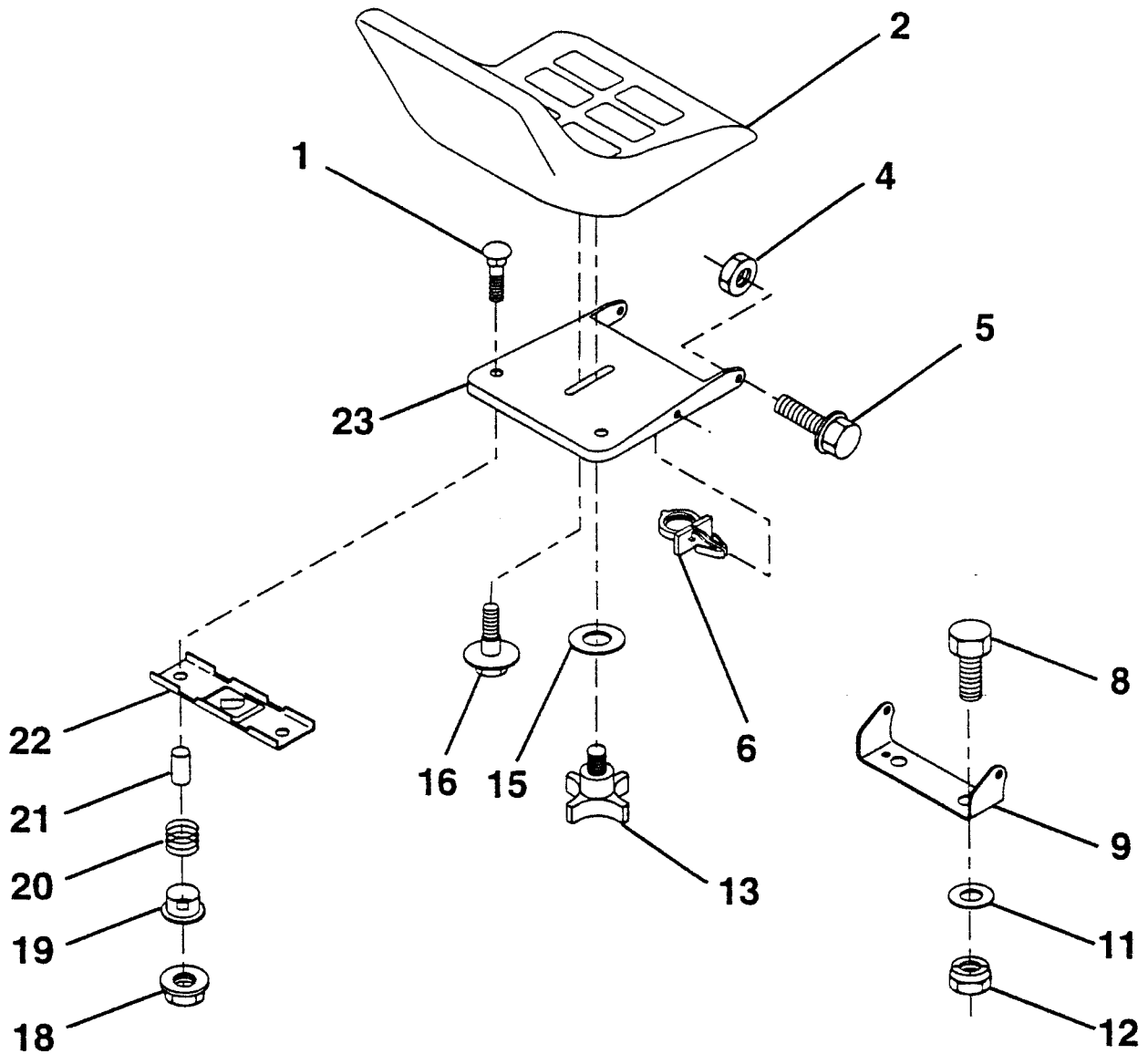

KEY NO.	PART NO.	DESCRIPTION
1	872050411	Bolt, Carriage 1/4-20 x 1-3/8
2	532127398	Seat
4	873800500	Nut, Hex, Lock w/wsh 5/16-18
5	532139888	Bolt, Shoulder 5/16-18 UNC
6	532140407	Clip, Insulated
8	874760616	Bolt, Hex, Fin. 3/8-16 UNC x 1
9	532140551	Bracket, Pivot, Seat
11	819133210	Washer 12/32 x 2 x 10 Gauge
12	873800600	Nut, Hex, Lock Hex w/wsh 3/8-16
13	532120068	Knob, Seat

KEY NO.	PART NO.	DESCRIPTION
15	819171912	Washer 17/32 x 1-3/16 x 12 Gauge
16	532127018	Bolt, Shoulder
18	532123976	Nut, Hex, Large, Flange Lock
19	532121248	Bushing, Snap
20	532121250	Spring, Compression
21	532134300	Spacer, Split, Large .28 id. x .96
22	532121246	Bracket, Switch Mounting
23	532140552	Pan, Seat

**NOTE:** All component dimensions given in U.S. inches  
1 inch = 25.4 mm

**HARDWARE SHOWN LARGER FOR EASIER IDENTIFICATION**

# REPAIR PARTS

TRACTOR-MODEL NO. LTH13 (HAR13H38B), PRODUCT NO. 954 00 10-42

DASH

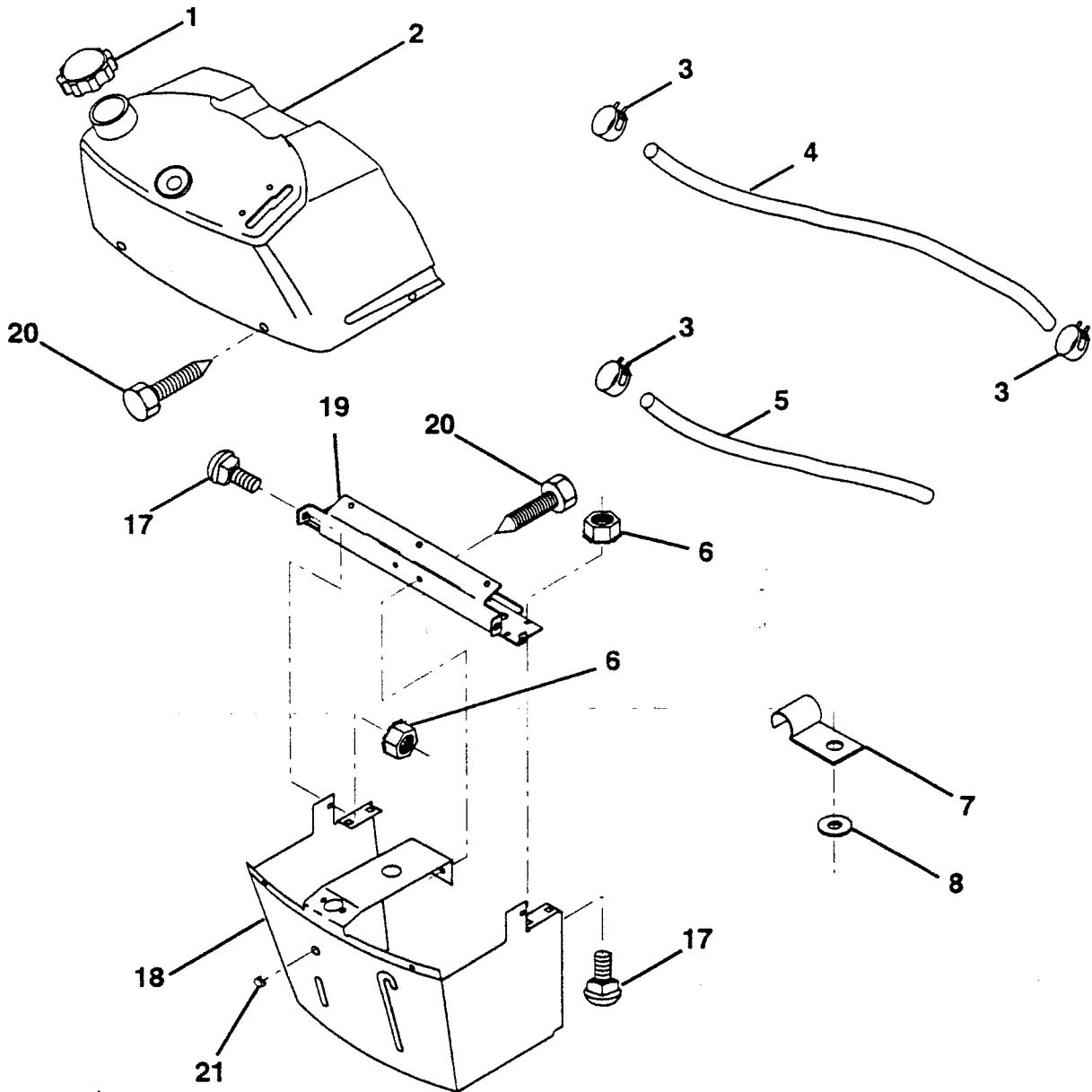

KEY NO.	PART NO.	DESCRIPTION
1	532142187	Cap, Fuel Tank
2	532138395	Assembly, Dash & Fuel Tank
3	532123487	Clamp, Hose
4	532008544	Line, Fuel
5	532008548	Line, Fuel
6	873510400	Nut, Hex, Keps 1/4-20
7	532124996	Clip, Fuel Line
8	819091216	Washer 9/32 x 3/4 x 16 Gauge

KEY NO.	PART NO.	DESCRIPTION
17	872110404	Bolt, Carriage 1/4-20 x 1/2 Grade 5
18	532131886	Support Assembly, Dash
19	532134744	Brace, Cross
20	817060408	Screw, Self-Tapping 1/4-20 x 1/2
21	532134014	Plug, Dome, Black

**NOTE:** All component dimensions given in U.S. inches  
1 inch = 25.4 mm

**HARDWARE SHOWN LARGER FOR EASIER IDENTIFICATION**

# REPAIR PARTS

TRACTOR-MODEL NO. LTH13 (HAR13H38B), PRODUCT NO. 954 00 10-42

## STEERING WHEEL

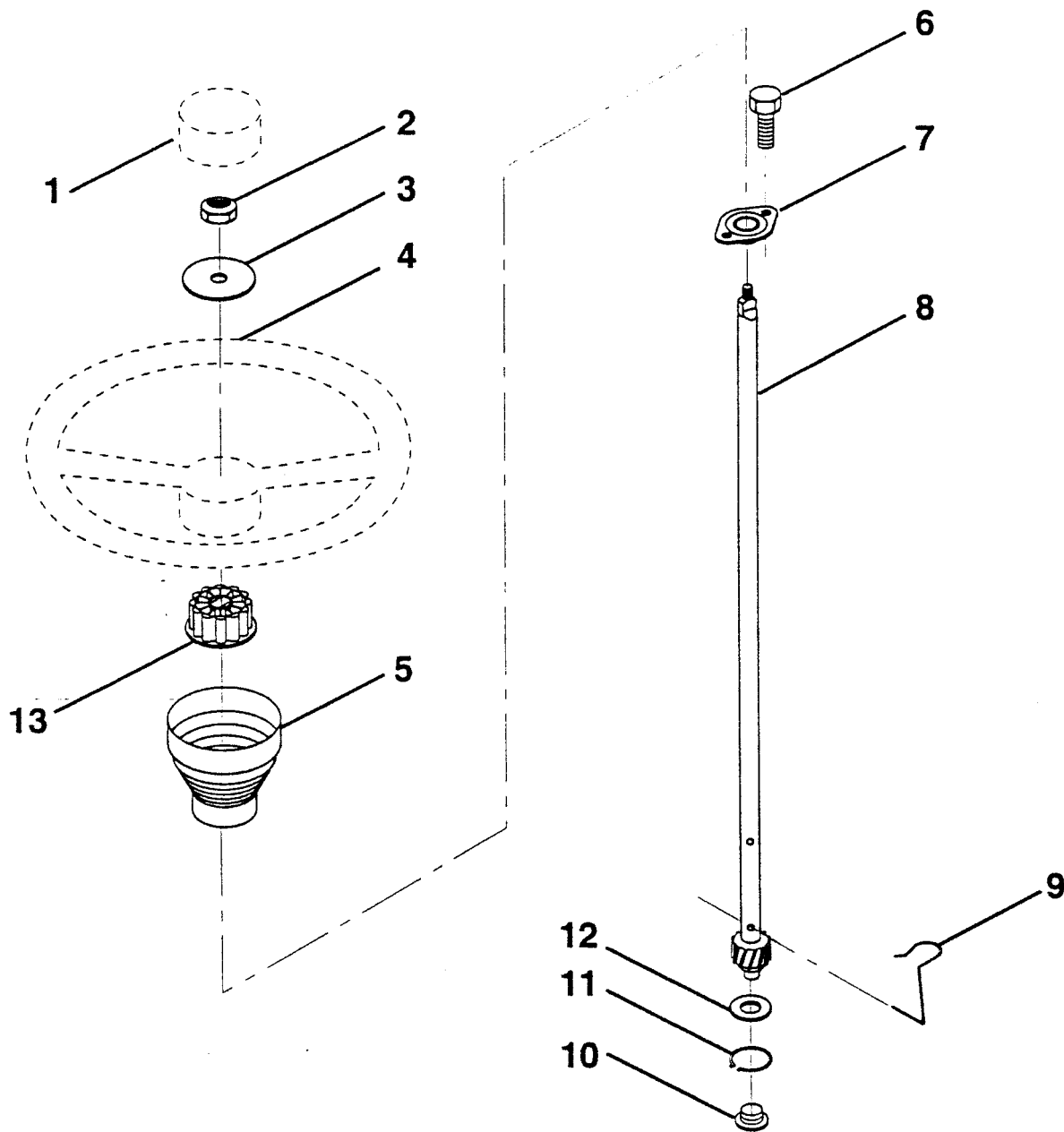

KEY NO.	PART NO.	DESCRIPTION
1	532124416	Insert, Steering Wheel
2	532124701	Locknut 3/8-24 UNF
3	819133808	Washer 12/32 x 2-3/8 x 8 Gauge
4	532124415	Steering Wheel
5	532127396	Sleeve, Steering
6	817431008	Screw, Hex Head #10-16 x 1/2

KEY NO.	PART NO.	DESCRIPTION
7	532102803	Bushing, Steering
8	532123651	Shaft, Steering
9	532124210	Clip, Steering
10	532123438	Bushing, Lower, Steering
11	812000045	Ring, Retaining
12	819211616	Washer 21/32 x 1 x 16 Gauge
13	532104820	Adaptor, Steering Wheel

**NOTE:** All component dimensions given in U.S. inches  
1 inch = 25.4 mm

**HARDWARE SHOWN LARGER FOR EASIER IDENTIFICATION**

# REPAIR PARTS

TRACTOR-MODEL NO. LTH13 (HAR13H38B), PRODUCT NO. 954 00 10-42

## BRAKE / REAR MOWER LIFT ASSEMBLY

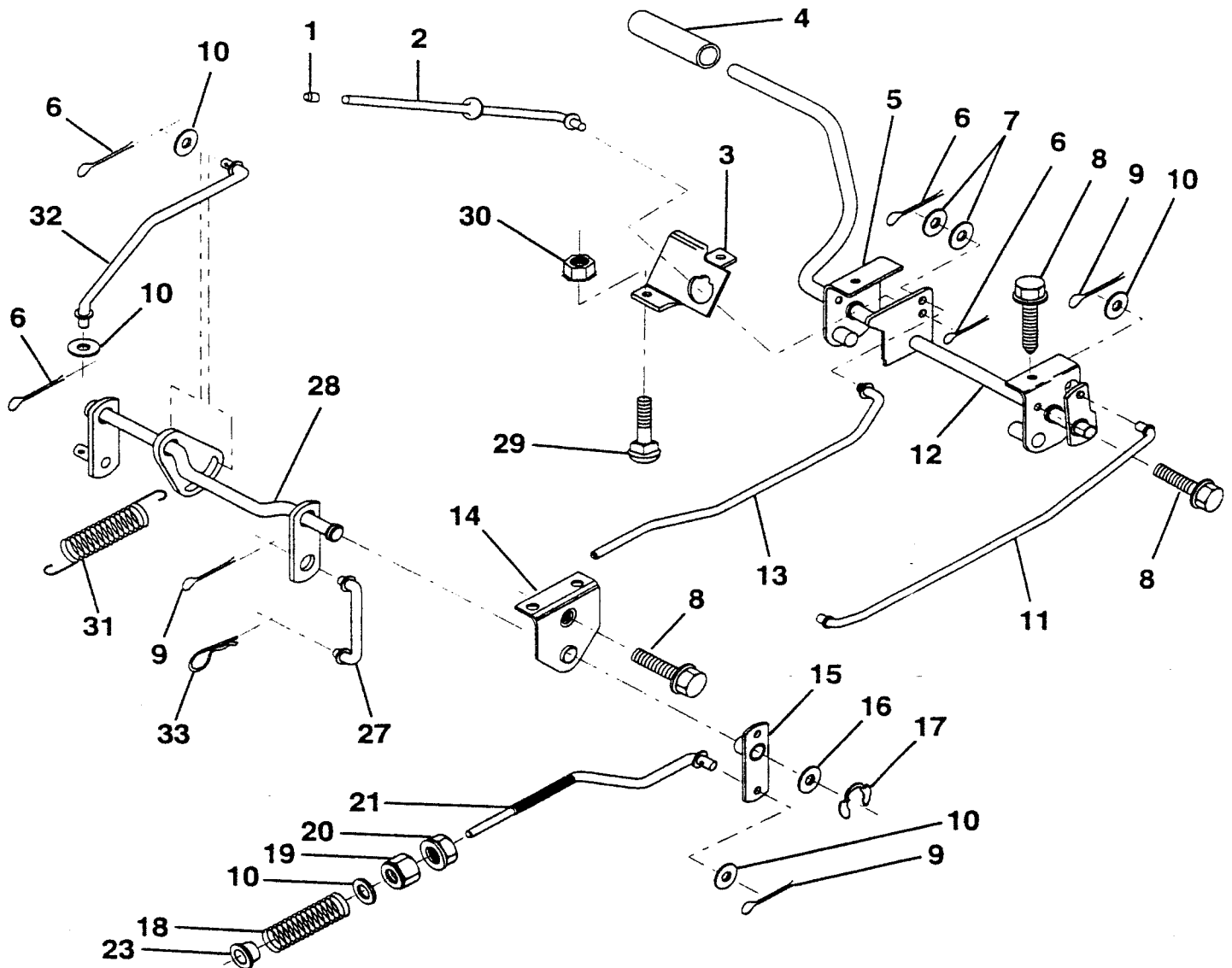

KEY NO.	PART NO.	DESCRIPTION	KEY NO.	PART NO.	DESCRIPTION
1	532071673	Cap, Plunger	15	532133332	Assembly, Brake, Pivot, Arm
2	532123436	Rod, Parking Brake	16	819251816	Washer 25/32 x 1-1/8 x 16 Gauge
3	532123437	Bracket, Parking Brake	17	812000034	Ring, Klip
4	532008156	Cover, Pedal	18	532106888	Spring, Brake Rod
5	532132205	Bracket, Clutch/Brake Pedal, L.H.	19	873350600	Nut, Hex, Jam 3/8-16 UNC
6	876020312	Pin, Cotter 3/32 x 3/4	20	873800600	Locknut, Hex, w/Wsh Ins 3/8-16 UNC
7	819131016	Washer 13/32 x 5/8 x 16 Gauge	21	532144413	Rod, Brake, Rear
8	817490508	Screw, Hex Head, Thd., Roll. 5/16-18 x 1/2	27	532136780	Link, Lift, Rear
9	876020412	Pin, Cotter 1/8 x 3/4	28	532140777	Assembly, Rear Mower Lift
10	819131316	Washer 13/32 x 13/16 x 16 Gauge	29	872110506	Bolt, Carriage 5/16-18 UNC x 3/4
11	532123543	Rod, Brake, Front	30	873510500	Nut, Hex, Keps 5/16-16 UNC
12	532139934	Assembly, Clutch/Brake Pedal	31	532133095	Spring, Counterbalance
13	532123394	Rod, Clutch	32	532133721	Link, Lift Lever
14	532121978	Bracket, Lift Shaft	33	532124670	Retainer Spring

**NOTE:** All component dimensions given in U.S. inches  
1 inch = 25.4 mm

**HARDWARE SHOWN LARGER FOR EASIER IDENTIFICATION**



# REPAIR PARTS

TRACTOR-MODEL NO. LTH13 (HAR13H38B), PRODUCT NO. 954 00 10-42

## FRONT AXLE

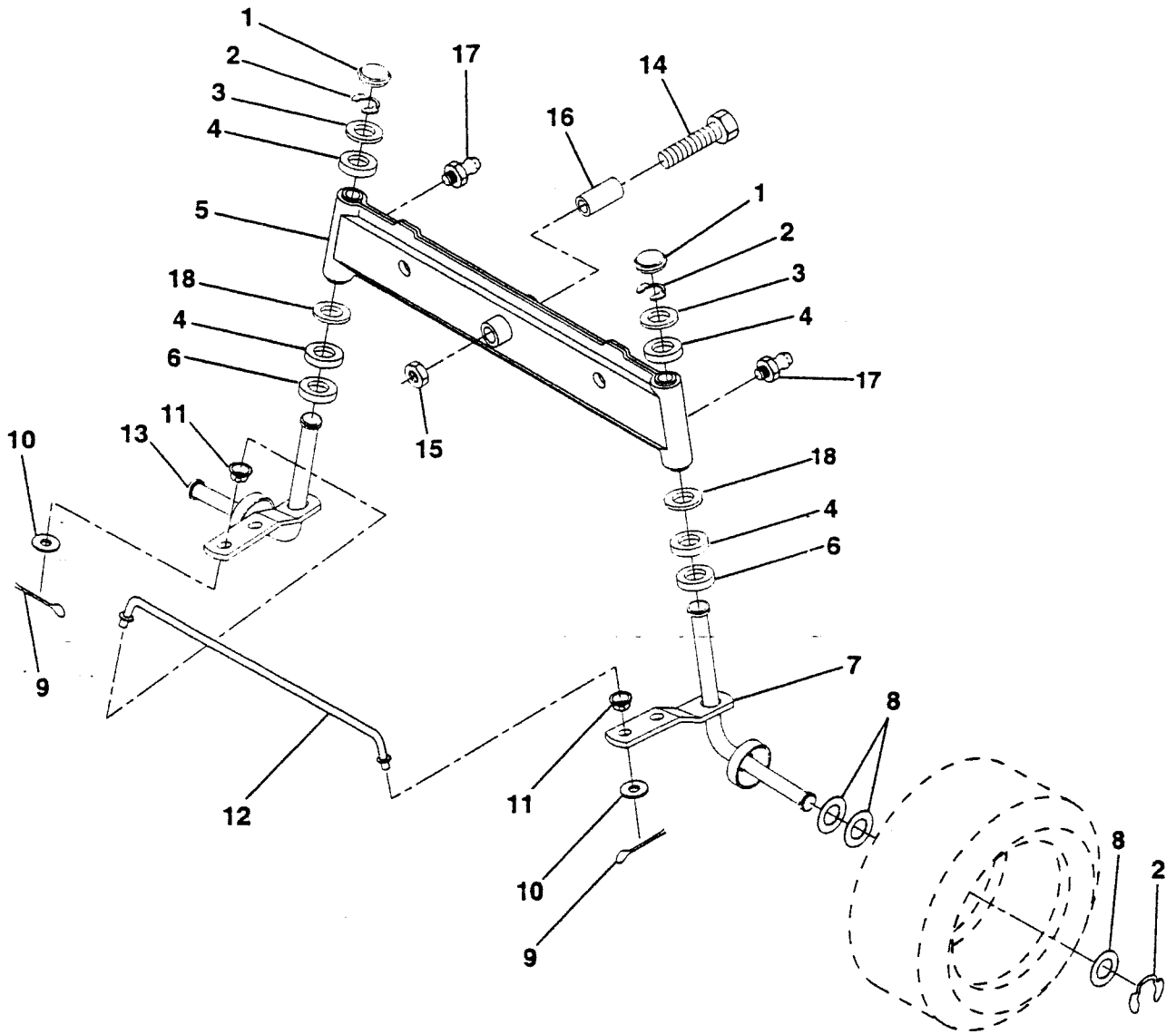

KEY NO.	PART NO.	DESCRIPTION
1	532121232	Cap, Spindle
2	812000029	Ring, Clip
3	532121748	Washer 25/32 x 1-5/8 x 16 Gauge
4	532124937	Bearing
5	532142033	Axle, Front
6	532124931	Bearing, Thrust
7	532137062	Spindle Assembly, R.H.
8	532121749	Washer 25/32 x 1-1/4 x 16 Gauge
9	876020412	Pin, Cotter 1/8 x 3/4
10	819131316	Washer 13/32 x 13/16 x 16 Gauge

KEY NO.	PART NO.	DESCRIPTION
11	532126847	Bushing
12	532130465	Tie Rod
13	532137061	Spindle Assembly, L.H.
14	874011056	Bolt Hex 5/8-11 Unc x 3-1/2
15	873901000	Nut Lock Flange 5/8-11 Unc
16	532110438	Spacer Bearing
17	532124836	Fitting Grease
18	819272016	Washer 27/32 x 1-1/4 x 16 Ga.

**NOTE:** All component dimensions given in U.S. inches  
1 inch = 25.4 mm

**HARDWARE SHOWN LARGER FOR EASIER IDENTIFICATION**

# REPAIR PARTS

TRACTOR-MODEL NO. LTH13 (HAR13H38B), PRODUCT NO. 954 00 10-42

## SECTOR GEAR / AXLE SUPPORT

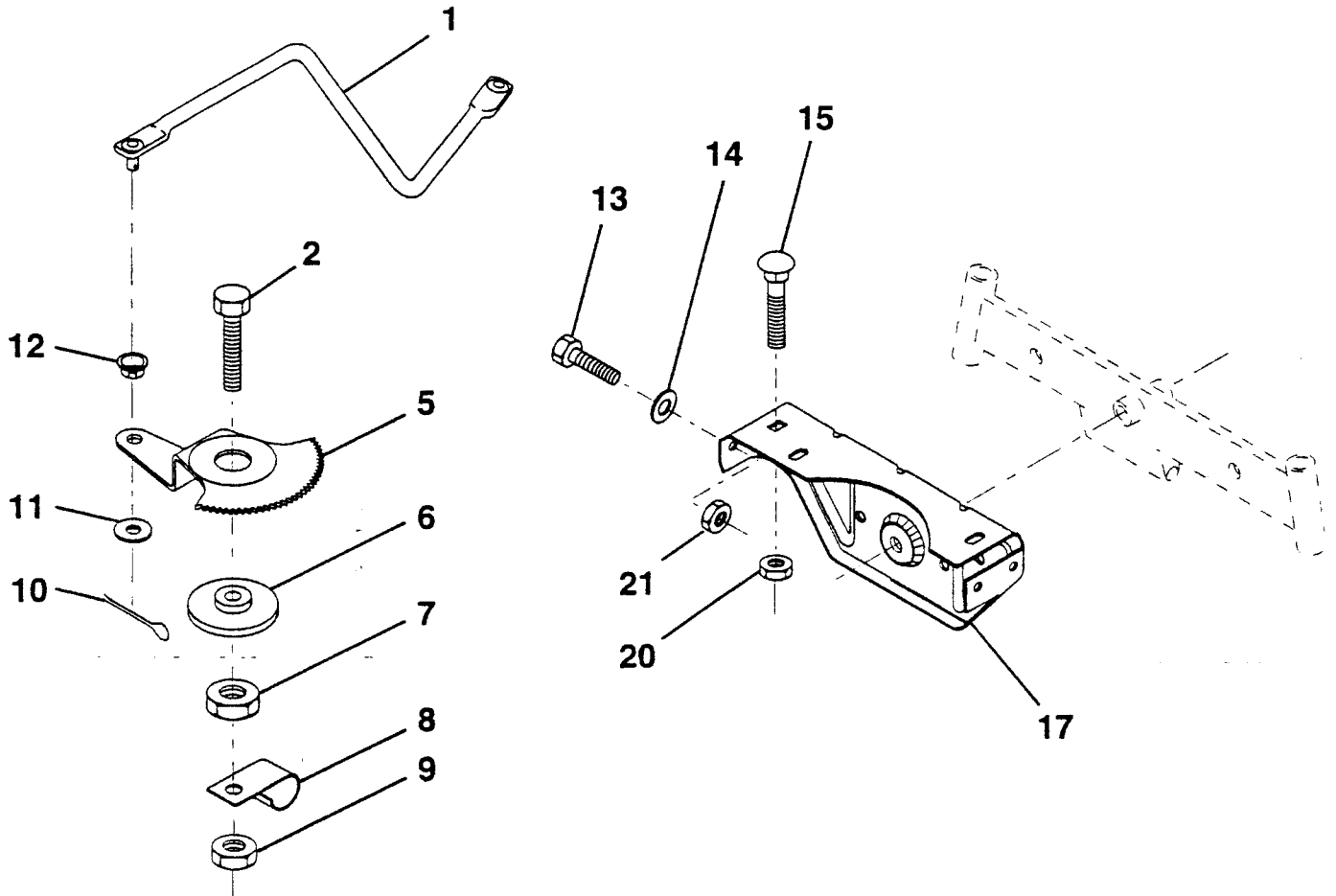

KEY NO.	PART NO.	DESCRIPTION
1	532132566	Link, Drag
2	874780828	Bolt, Hex, Fin. 1/2-13 x 1-3/4
5	532121926	Gear, Sector
6	532121927	Bushing
7	873030800	Nut, Heavy Hex, Top Lock 1/2-13 UNC
8	532126472	Clip, Insulated
9	873680800	Nut, Crownlock 3/8-16
10	876020412	Pin, Cotter 1/8 x 3/4
11	819131316	Washer 13/32 x 13/16 x 16 Gauge

KEY NO.	PART NO.	DESCRIPTION
12	532126847	Bushing
13	874760512	Bolt, Hex Head 5/16-18 UNC x 1
14	819111416	Washer 11/32 x 7/8 x 16 Gauge
15	872110606	Bolt, Carriage 3/8-16 UNC x 3/4
17	532137096	Support, Front Axle
20	873800600	Nut, Hex, Lock Hex w/wsh 3/8-16
21	873800500	Nut, Hex, Lock Hx w/Ins 5/16-18

**NOTE:** All component dimensions given in U.S. inches  
1 inch = 25.4 mm

**HARDWARE SHOWN LARGER FOR EASIER IDENTIFICATION**

# REPAIR PARTS

TRACTOR-MODEL NO. LTH13 (HAR13H38B), PRODUCT NO. 954 00 10-42

## ENGINE

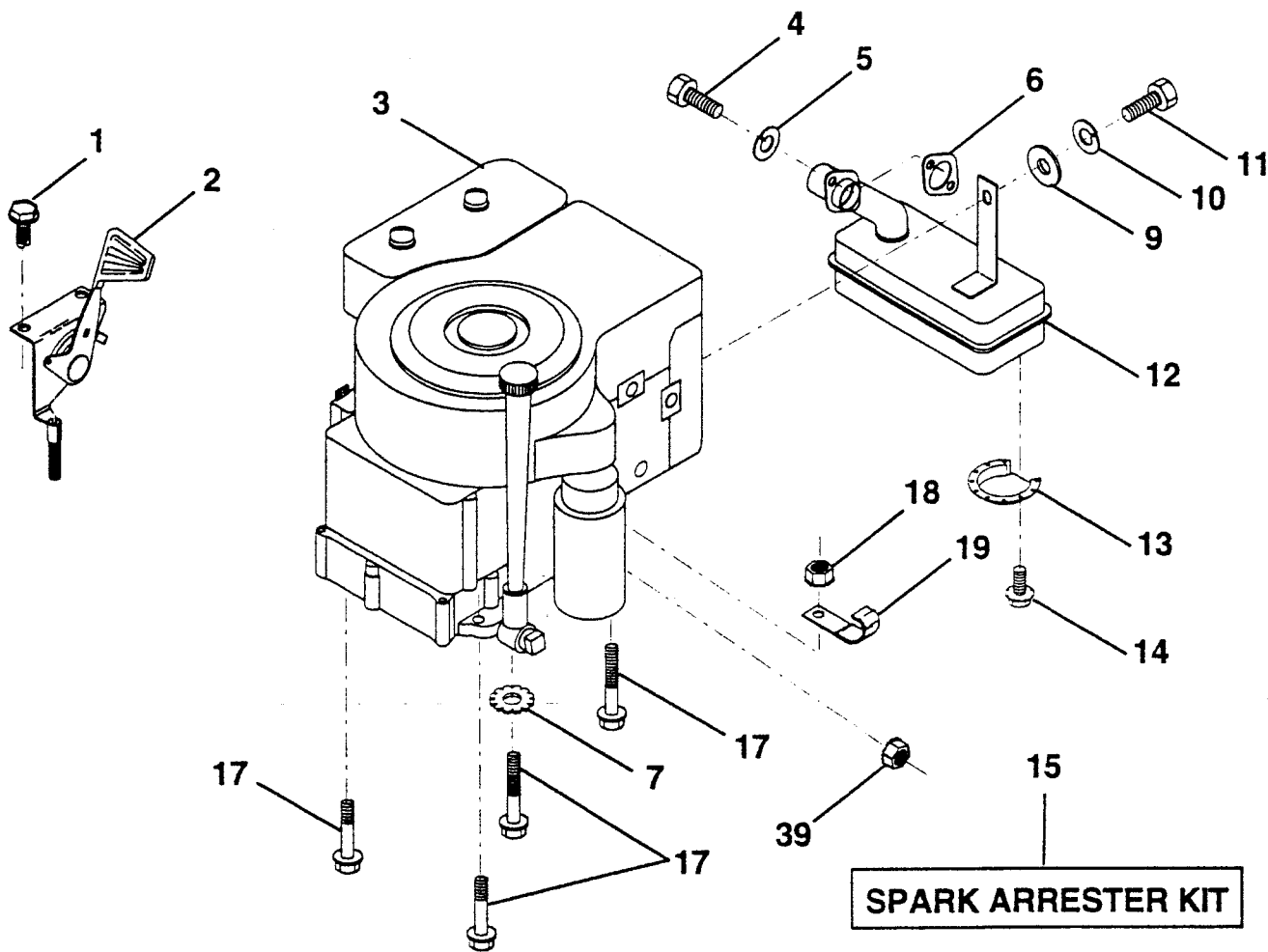

KEY NO.	PART NO.	DESCRIPTION
1	817060408	Screw, Hex Head, Thread Cutting 1/4-20 x 1/2
2	532133025	Control, Throttle
3	532145301	Engine, B&S, 13 HP, Vanguard Dual Model Number 28P777
5	810040500	Washer, Lock, Hvy Hlcl Spring 5/16
6	532125593	Gasket Eng.
7	811050600	Washer Lock Ext. Tooth 3/8
10	810040400	Washer, Lock Hvy Helical 1/4
11	817490416	Screw 1/4-20 x 1.00 77
12	532142380	Muffler
13	532144986	Deflector Muffler

KEY NO.	PART NO.	DESCRIPTION
14	817030808	Screw
15	532137180	Arrester, Spark (Optional Equipment)
16	532127951	Stop Throttle 3000 RPM
17	817490624	Screw Thdrol 3/8-16 x 1-1/2
18	873800600	Nut, Lock Hex W/Ins. 3/8-16
19	532124996	Clip, Fuel Line
24	817490620	Screw Thdrol 3/8-16 x 1-1/4
25	874570512	Screw Hex SKT 5/16 UNC x 3/4
26	819091210	Washer 9/32 x 3/4 x 10 Ga.
39	873510400	Nut, Keps, Hex Hd. 1/4-20

**NOTE:** All component dimensions given in U.S. inches  
1 inch = 25.4 mm

**HARDWARE SHOWN LARGER FOR EASIER IDENTIFICATION**

# REPAIR PARTS

TRACTOR-MODEL NO. LTH13 (HAR13H38B), PRODUCT NO. 954 00 10-42

## GROUND DRIVE

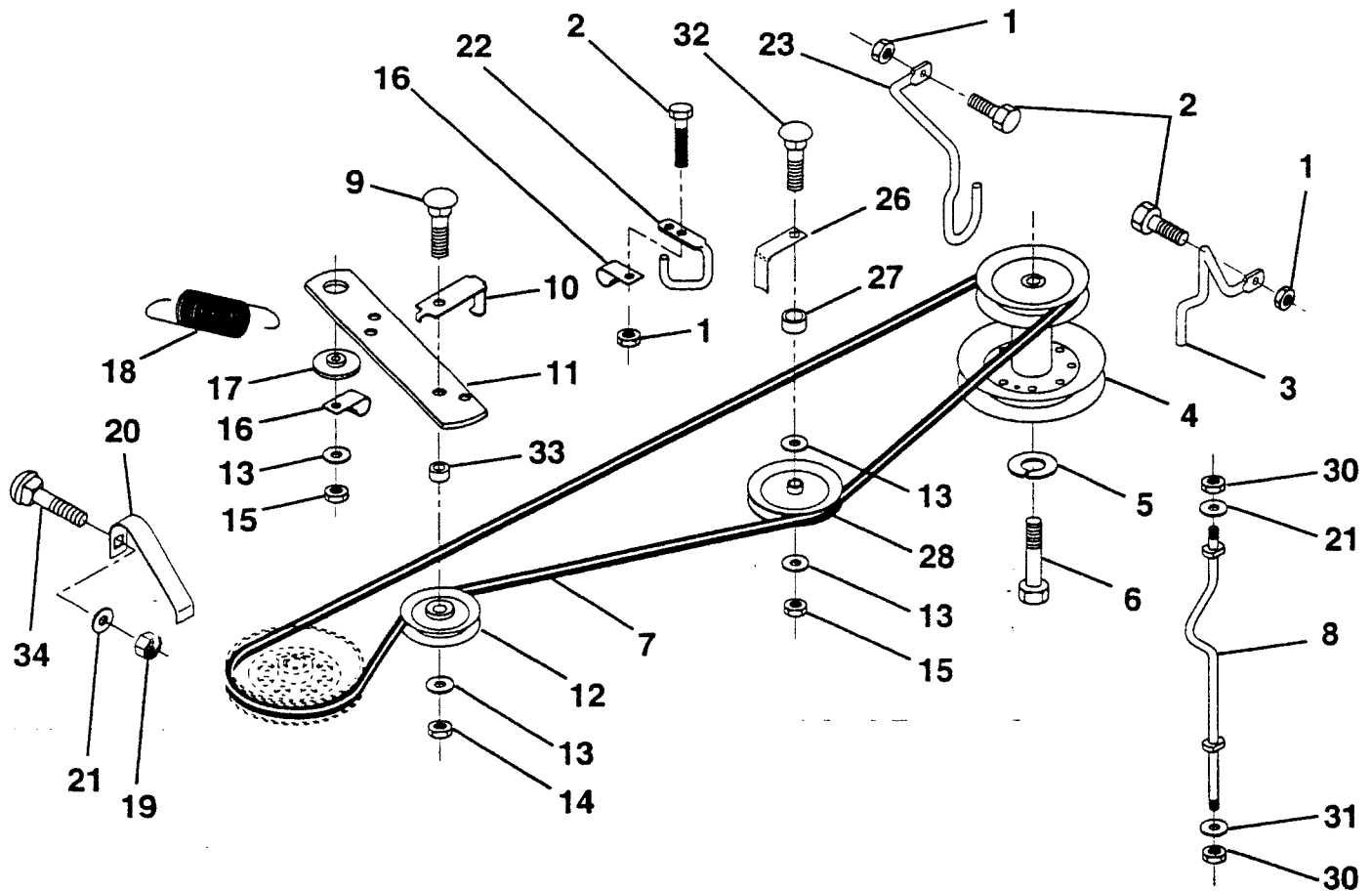

KEY NO.	PART NO.	DESCRIPTION	KEY NO.	PART NO.	DESCRIPTION
1	873800500	Nut, Lock Hx w/Ins 5/16-18	18	532131459	Spring, Extension
2	874760512	Bolt, Hex Head 5/16-18 x 3/4	19	873800500	Nut
3	532140917	Keeper, Belt RH Front	20	532140909	Keeper, Belt LH
4	532138029	Pulley, Engine	21	819111116	Washer Nut Lock Hex w/Ins. 5/6-18
5	810040700	Washer, Lock 7/16	22	532123404	Keeper Frame Ground Drive Belt
6	871170744	Bolt, Hex Fin 7/16-20 Gr. 5	23	532146792	Keeper, Belt LH Front
7	532140910	V-Belt	26	532140913	Keeper, Belt
8	532140785	Keeper, Belt RH	27	532140914	Spacer
9	872140618	Bolt, RDHD SQ 3/8-16 x 2-1/4	28	532139123	Pulley, V-Idler
10	532140780	Keeper, Belt, Idler Pulley	30	873800500	Nut Lock Hex w/Ins. 5/16-18
11	532140911	Arm, Idler	31	819111216	Washer 11/32 x 3/4 x 16 Ga.
12	532123674	Idler, Flat	32	872140620	Carriage Bolt
13	819131316	Washer 13/32 x 13/16 x 16 Gauge	33	532000160	Spacer
14	873930600	Nut, Centerlock 3/8-16	34	872140506	Carriage Bolt
15	873800600	Nut, Hex, Lock Hex w/wsh 3/8-16			
16	532126472	Clip Insulator			
17	532122052	Spacer, Retainer			

**NOTE:** All component dimensions given in U.S. inches  
1 inch = 25.4 mm

**HARDWARE SHOWN LARGER FOR EASIER IDENTIFICATION**

# REPAIR PARTS

TRACTOR-MODEL NO. LTH13 (HAR13H38B), PRODUCT NO. 954 00 10-42

## TRANSAXLE

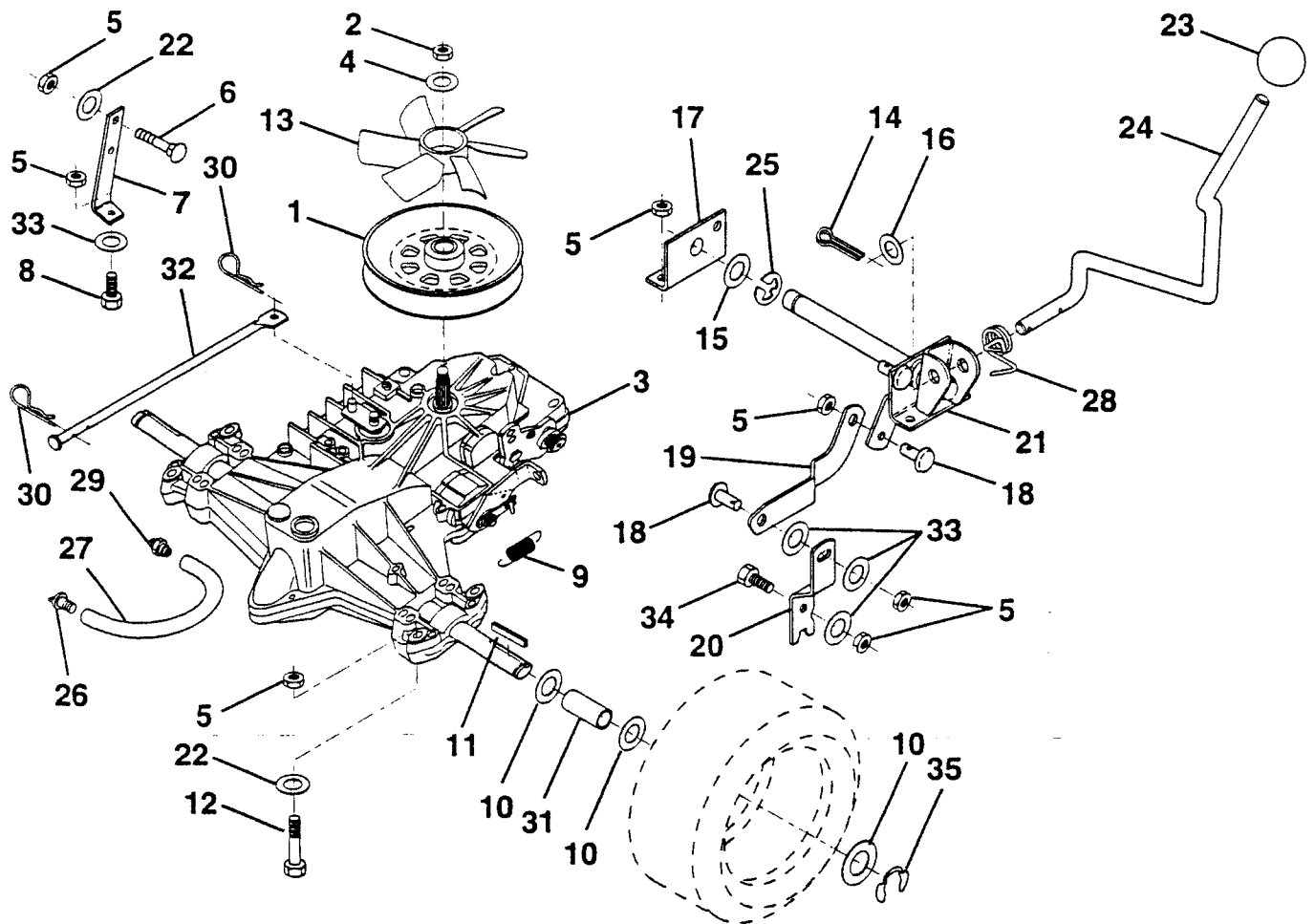

KEY NO.	PART NO.	DESCRIPTION
1	532140779	Pulley
2	532009204	Nut Lock 1/2-20 UNF x 3/4 x 7/16
3	532140607	Transaxle, Hydro 0310-0500
4	819171912	Washer 17/32 x 1-3/16 x 12 Ga.
5	873800500	Nut Lock Hex w/Ins. 5/16-18
6	872140506	Bolt, Carriage
7	532140774	Strap, Torque
8	874760524	Bolt Fin Hex 5/16-18 x 1-1/2
9	532110422	Spring Brake
10	532121749	Washer 25/32 x 1-1/4 x 16 Gauge
11	532123583	Key, Square
12	874760540	Bolt, Hex Head 5/16-18 x 2-1/2
13	532140778	Fan, Transaxle, Hydro
14	876020416	Pin, Cotter 1/8 x 1
15	819212013	Washer 21/32 x 1-1/4 x 13 Ga.
16	819171216	Washer 17/32 x 3/4 x 16 Ga.
17	532140763	Support, Shift Handle

KEY NO.	PART NO.	DESCRIPTION
18	532140769	Pivot Pin
19	532140767	Link, Shift
20	532140773	Lever, Shift
21	532140764	Pivot Shaft Assembly
22	819111116	Washer 11/32 x 11/16 x 16 Ga.
23	532140845	Knob, Shifter
24	532140765	Rod, Shifter
25	812000002	E-Ring
26	-----	Cap, Vent Hose
27	532142564	Hose, Vent
28	532140772	Spring, Torsion
29	-----	Nipple, Vent Hose
30	532124788	Retainer Spring
31	532121199	Spacer
32	532140912	Actuator, Bypass, Hydro
33	819111216	Washer 11/32 x 3/4 16 Ga.
34	874760516	Bolt Hex Hd. 5/16-18 x 1
35	812000001	E-Ring

**NOTE:** All component dimensions given in U.S. inches  
1 inch = 25.4 mm

**HARDWARE SHOWN LARGER FOR EASIER IDENTIFICATION**

# REPAIR PARTS

TRACTOR-MODEL NO. LTH13 (HAR13H38B), PRODUCT NO. 954 00 10-42

## MOWER LIFT LEVER

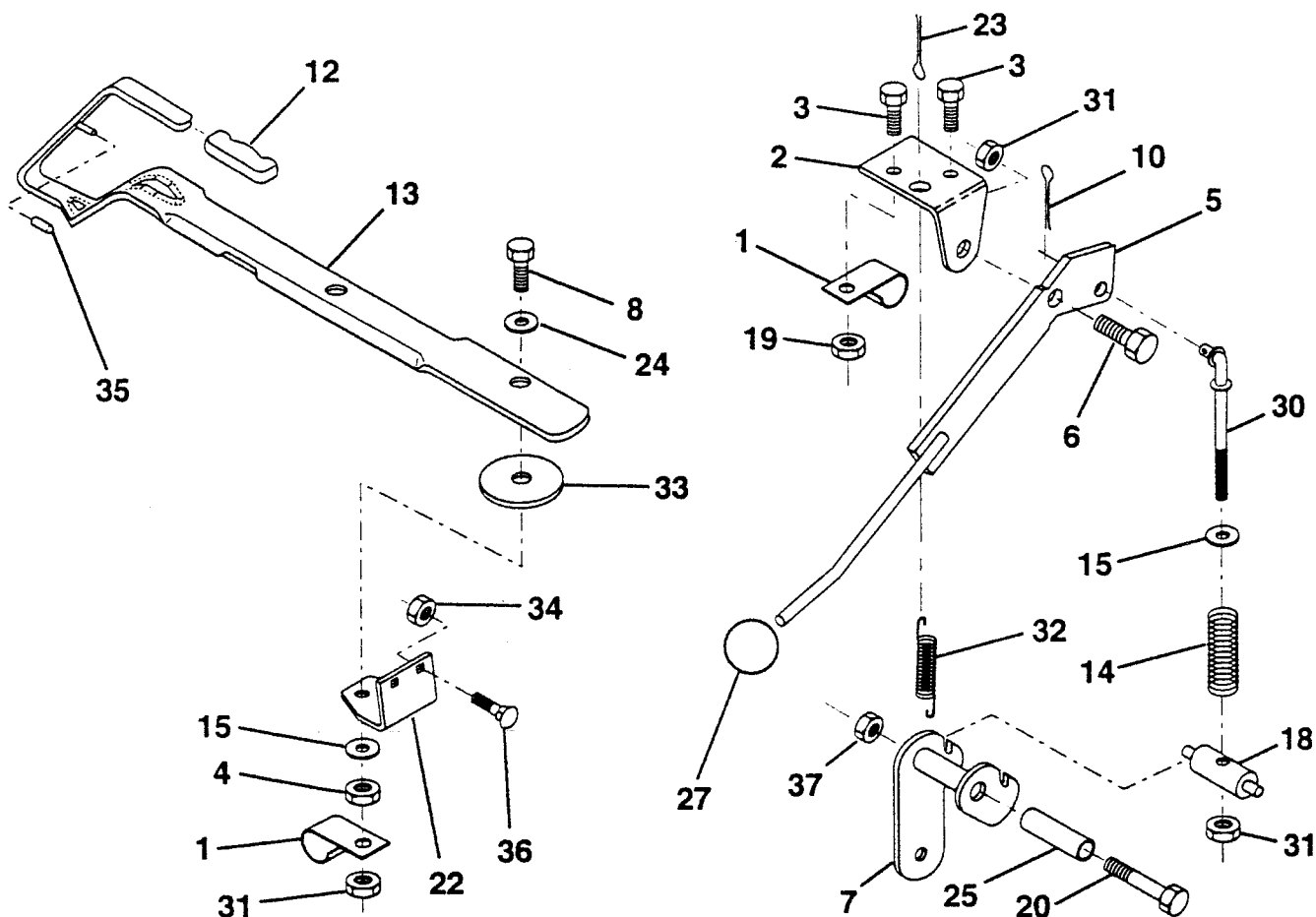

KEY NO.	PART NO.	DESCRIPTION	KEY NO.	PART NO.	DESCRIPTION
1	532126470	Clip, Insulated	20	874760644	Bolt, Hex Head, Fin. 3/8-16 UNC x 2-3/4
2	532122018	Bracket, Mower Clutch	22	532132561	Bracket, Lift Lever
3	874780408	Bolt, Hex Head, Fin. 1/4-20 UNC x 1/2 Grade 5	23	876020312	Pin, Cotter 3/32 x 3/4
4	873800600	Nut, Lock Hex W/Ins. 3/8-16	24	532007672	Washer 25/64 x 1-1/4 x 12 Gauge
5	532132552	Assembly, Clutch Lever	25	532121933	Tube, Spacer
6	532106451	Bolt, Shoulder	27	532121466	Knob
7	532141435	Assembly, Mower Clutch Arm	30	532135039	Rod, Tension, Clutch
8	874930624	Bolt, Hex Head 3/8-16 UNC x 1-1/2	31	873800600	Nut Lock Hex w/wsh 3/8 - 16
10	876020412	Pin, Cotter 1/8 x 3/4	32	532133435	Spring, Extension, Return
12	532122027	Handle, Lift Lever	33	532062333	Washer .390 x 1.437 x .074
13	532136658	Assembly, Lift Handle	34	873800500	Nut, Lock Hx w/Ins 5/16-18
14	532133939	Spring, Compression	35	532133603	Cap, Vinyl, Red
15	819131616	Washer 13/32 x 1 x 11 Gauge	36	872140506	Bolt, Carriage 5/16-18 x 3/4
18	532135107	Trunnion, Threaded 3/8-16	37	873680600	Nut Crownlock 3/8-16
19	873680400	Nut, Crownlock 1/4-20			

**NOTE:** All component dimensions given in U.S. inches  
1 inch = 25.4 mm

**HARDWARE SHOWN LARGER FOR EASIER IDENTIFICATION**

# REPAIR PARTS

TRACTOR-MODEL NO. LTH13 (HAR13H38B), PRODUCT NO. 954 00 10-42

## DECALS

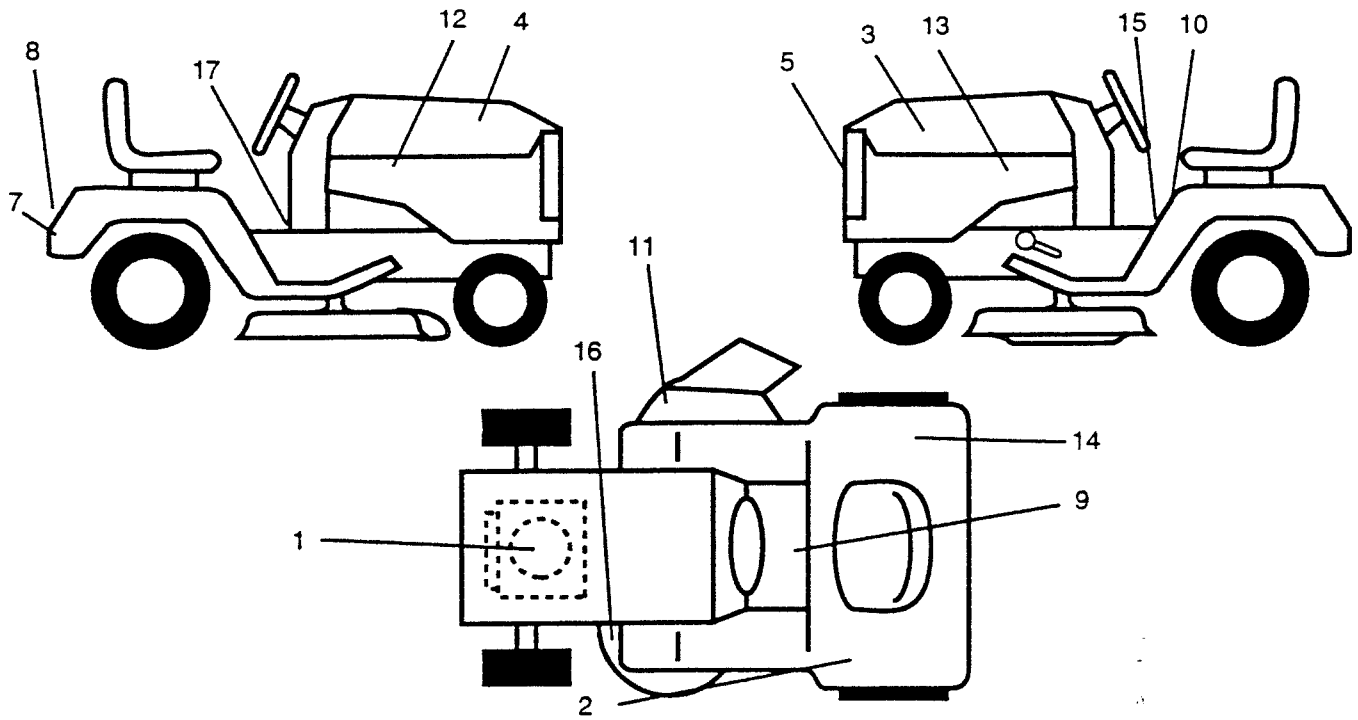

KEY NO.	PART NO.	DESCRIPTION
1	532272780	Decal, Engine, B&S 13 hp Vang.
2	532135073	Decal, Indicator, Height
3	532140206	Decal, Hood, L.H.
4	532140205	Decal, Hood, R.H.
5	532140213	Decal, Logo, Grill
7	532141484	Decal, Drawbar
8	532131582	Decal, Logo, Fender
9	532142336	Decal, Cold Start

KEY NO.	PART NO.	DESCRIPTION
10	532133796	Decal, Fender, Caution
11	532137259	Decal, Warning, Multi-Language
12	532141280	Decal, Hood, Insert, R.H.
13	532141281	Decal, Hood, Insert, L.H.
14	532124433	Decal 80 DBA
15	532138272	Decal, Instruction, Operating
16	532136832	Decal, V-Belt Schematic
17	532142336	Decal Cold Start Hydro
--	532147504	Manual, Operator's
--	532147505	Manual, Repair Parts

Available accessories not included with tractor.

-- CER 38 Grass Catcher

## WHEELS & TIRES

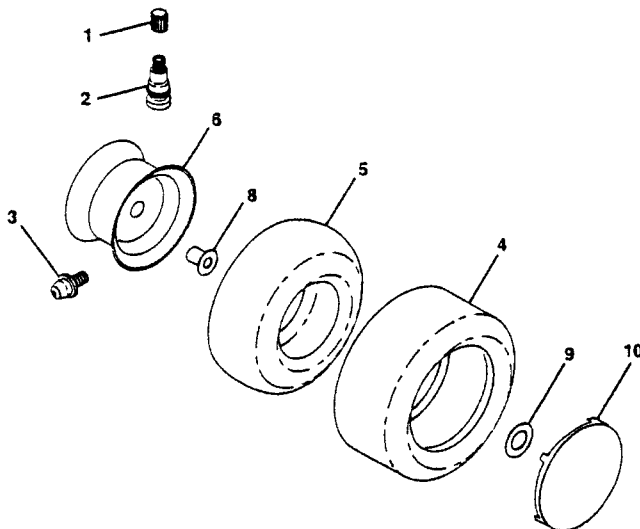

KEY NO.	PART NO.	DESCRIPTION
1	532059192	Cap, Valve Stem
2	532065139	Stem, Valve
3	532124957	Fitting, Grease (Front Wheels Only)
4	532137422	Tire, Front
	532132703	Tire, Rear
5	532059904	Tube, Front Tire
		(Optional - Service Item Only)
	532008134	Tube, Rear Tire
		(Optional - Service Item Only)
6	532142537	Rim, Front
	532140453	Rim, Rear
8	532124959	Bearing Flange
9	532121748	Washer 25/32 x 1-5/8 x 16 Gauge
10	532124577	Wheel cover
	532124578	Wheel cover

**NOTE:** All component dimensions given in U.S. inches  
1 inch = 25.4 mm

# REPAIR PARTS

TRACTOR-MODEL NO. LTH13 (HAR13H38B), PRODUCT NO. 954 00 10-42

## MOWER DECK

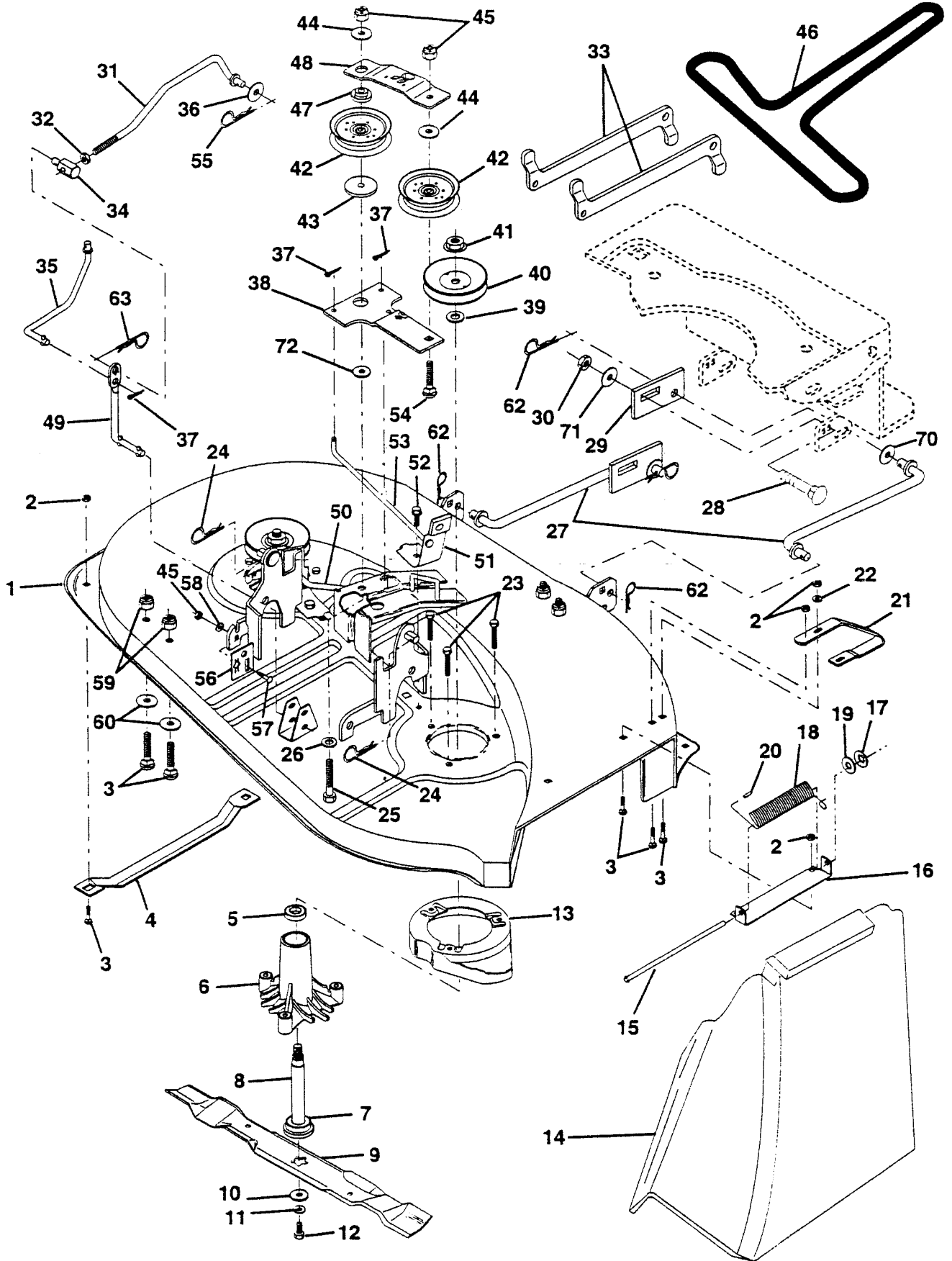



# REPAIR PARTS

TRACTOR-MODEL NO. LTH13 (HAR13H38B), PRODUCT NO. 954 00 10-42

## MOWER DECK

KEY NO.	PART NO.	DESCRIPTION	KEY NO.	PART NO.	DESCRIPTION
1	532142830	Mower Deck Assembly	38	532133840	Idler Arm
2	873800500	Nut, Lock Hx w/Ins 5/16-18	39	532129963	Washer .150 Thick
3	872140506	Bolt, Carriage 5/16-18 x 3/4	40	532129206	Pulley, Mandrel
4	532125074	Runner, L.H.	41	532137266	Nut, Flangelock 9/16
5	532110485	Bearing	42	532121316	Pulley, Flat Idler
6	532128774	Housing, Mandrel	43	532122052	Spacer, Retainer
7	532129895	Bearing	44	819131612	Washer 13/32 x 1 x 12 Gauge
8	532137645	Shaft and Bearing Assembly, Mandrel (Includes Key Number 7)	45	873800600	Nut, LockHex W/Ins. 3/8-16 UNC
9	532138497	Blade	46	532126520	Belt
10	532140296	Washer, Hardened	47	532133502	Spacer, Idler Arm
11	810030600	Washer, Lock 3/8	48	532133503	Stiffener, Idler Arm
12	532850857	Bolt, Hex 3/8-24 x 1-1/4 Grade 8	49	532133551	Rod, Pivot
13	532140329	Stripper, Mower, Vented	50	532131289	Rod, Brake, L.H.
14	532106736	Shield, Deflector	51	532130840	Brake Assembly
15	532106735	Rod, Hinge	52	817490512	Screw, Hex Washer Head, Thd., Roll. 5/16-18 x 3/4
16	532137607	Bracket Assembly, Deflector	53	532131288	Rod, Brake, R.H.
17	532110452	Pushnut	54	872110614	Bolt, Carriage 3/8-16 x 1-3/4 Grade 5
18	532123713	Spring, Deflector	55	532124961	Spring, Retainer
19	819111016	Washer 11/32 x 5/8 x 16 Gauge	56	532136782	Adjustment Plate, Rear Link, L.H.
20	532105304	Cap, Sleeve	57	872140608	Bolt, Carriage 3/8-16 x 1
21	532128772	Runner, R.H.	58	819131212	Washer 13/32 x 3/4 x 12 Gauge
22	819111216	Washer 11/32 x 3/4 x 16 Gauge	59	873800500	Locknut, Hex, with Washer Insert 5/16-18
23	532138776	Screw Thdrol Hex Head Zinc MWR	60	819111112	Washer 11/32 x 11/16 x 12 Gauge
24	532124670	Retainer, Spring	62	532124660	Retainer Spring
25	874600636	Bolt Hex 3/8-16 x 2-1/4	63	532124788	Retainer Spring
26	819131612	Washer 13/32 x 1 x 12 Gauge	70	819162016	Washer 1/2 x 1-1/4 x 16 Ga.
27	532139756	Link Assembly, Front	71	819131610	Washer Flat 13/32 x 1 x 10 Ga.
28	872140608	Bolt RDHD SQNK 3/8 - 16 x 1	72	532133943	Washer Hardened
29	532139757	Plate Slide Link	--	532130794	Mandrel Assembly (Includes Key Numbers 5-8, 10-12, 39 and 41)
30	873800600	Nut, Lock Hex w/washer 3/8 - 16	--	532142862	Mower Deck, Complete (Std. Deck Order Mulcher Plate Components Separately Key Nos. 64-69)
31	532140915	Clutch Rod, Primary			
32	873350600	Nut, Hex, Jam 3/8-16			
33	532132559	Arm, Suspension, Rear			
34	532133604	Trunnion 3/8-16			
35	532132554	Clutch Rod, Secondary			
36	819131316	Washer 13/32 x 13/16 x 16 Gauge			
37	876020312	Pin, Cotter 3/32 x 3/4			

**NOTE:** All component dimensions given in U.S. inches  
1 inch = 25.4 mm

HARDWARE SHOWN LARGER FOR EASIER IDENTIFICATION

# REPAIR PARTS

TRACTOR-MODEL NO. LTH13 (HAR13H38B), PRODUCT NO. 954 00 10-42

## ELECTRICAL

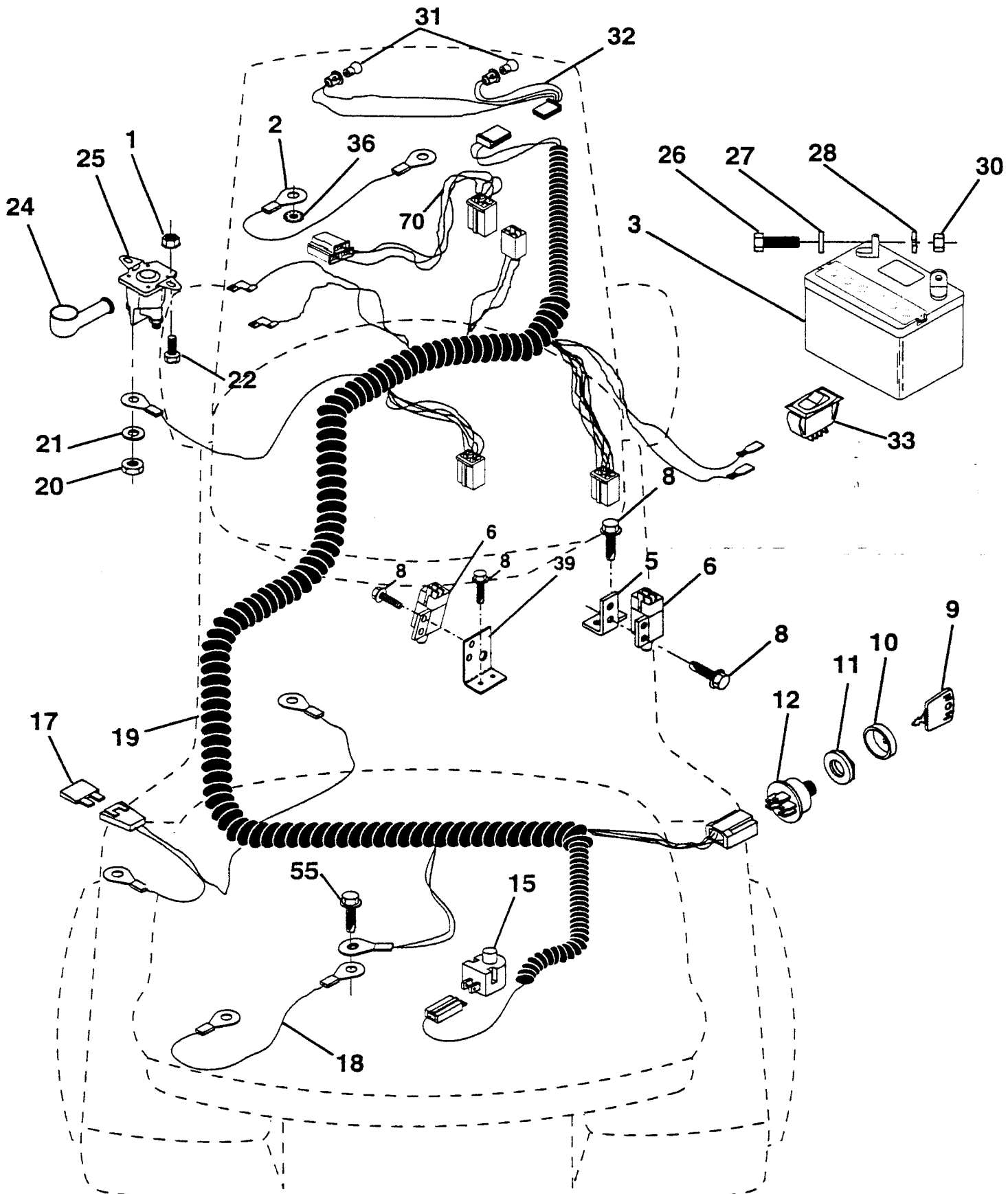

# REPAIR PARTS

TRACTOR-MODEL NO. LTH13 (HAR13H38B), PRODUCT NO. 954 00 10-42

## ELECTRICAL

KEY NO.	PART NO.	DESCRIPTION
1	873640400	Nut, Hex, Keps 1/4-20
2	532108423	Assembly, Cable
3	532144924	Battery
5	532108236	Bracket, Switch
6	532109553	Switch, Interlock, 4 Terminal
8	817021008	Screw, Hex Head, Self-Tapping #10-24 x 1/2
9	532140401	Key, Molded
10	532141226	Cover, Ignition Key
11	532140400	Nut, Ignition
12	532144921	Switch, Ignition
15	532121305	Switch, Plunger
17	532108824	Fuse
18	532128353	Assembly, Cable
19	532146064	Harness, Ignition
20	873350400	Nut, Hex, Jam 1/4-20
21	810090400	Washer, Lock 1/4
22	874780408	Bolt, Hex, Fin. 1/4-20 UNC x 1/2 Grade 5
24	532131563	Cover, Terminal
25	532145673	Solenoid
26	874760412	Bolt, Hex Head 1/4-20 UNC x 3/4
27	819091016	Washer 9/32 x 5/8 x 16 Gauge
28	810040400	Washer, Lock 1/4
30	873220400	Nut, Hex, Fin. 1/4-20 UNC
31	532004152	Bulb, Light
32	532142881	Harness, Headlight
33	532110712	Switch, Light
36	811150400	Washer, Lock, Internal Tooth 1/4
39	532141735	Bracket Switch Clutch
55	817490508	Screw Thdrol 5/16 - 18 x 1/2
70	532140422	Engine Harness

**NOTE:** All component dimensions given in U.S. inches  
1 inch = 25.4 mm

**HARDWARE SHOWN LARGER FOR EASIER IDENTIFICATION**

# REPAIR PARTS

TRACTOR-MODEL NO. LTH13 (HAR13H38B), PRODUCT NO. 954 00 10-42  
TRANSAXLE HYDROGEAR, MODEL NO. 310-0500

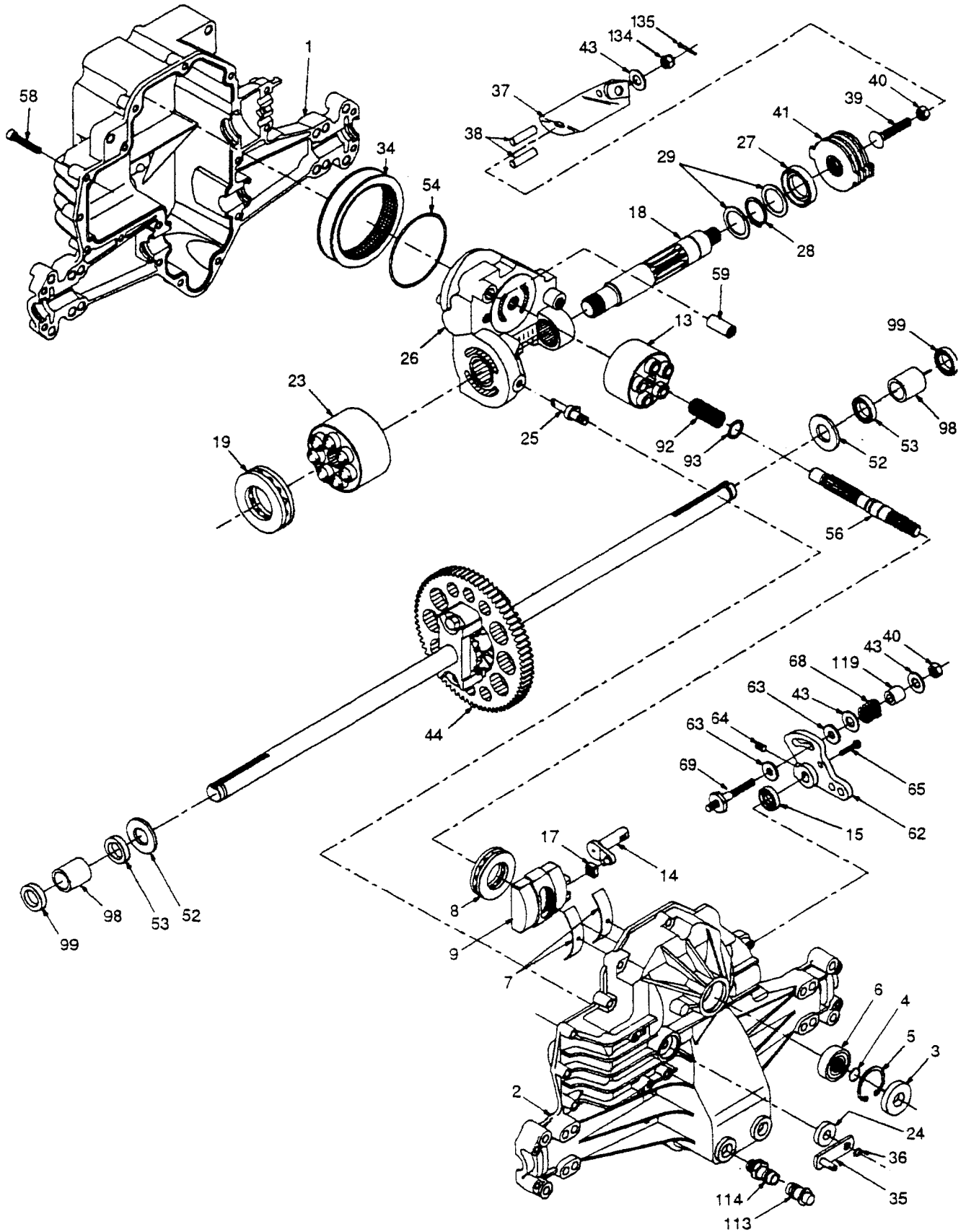

# REPAIR PARTS

TRACTOR-MODEL NO. LTH13 (HAR13H38B), PRODUCT NO. 954 00 10-42  
TRANSAXLE HYDROGEAR, MODEL NO. 310-0500

KEY PART NO. NO.	DESCRIPTION	KEY PART NO. NO.	DESCRIPTION		
1	532142986	Housing, Lower	40	532142957	Locknut, Hex 5/16-24 UNJC
2	532142987	Assembly, Upper Housing	41	532142958	Brake Rotor/Stator Kit
3	532142932	Seal, Lip	43	532142884	Washer 7/16 x 7/8 x .060
4	532142928	Ring, Wire Retaining	44	532142990	Differential Assembly
5	532142933	Ring, Retaining	52	532142991	Washer 3/4 x 1.5 x .13
6	532142934	Bearing, Shaft Ball	53	532142961	Seal .75 x 1.25 x .250
7	532142935	Bearing, Cradle	54	532142962	O-Ring .103 x 2.987 ID
8	532142936	Bearing, Thrust 30 x 52 x 13	56	532142963	Shaft, Input
9	532142937	Swashplate, Variable	58	532142964	Bolt 1/4-20 x 1.38
13	532142938	Block, Cylinder Assembly	59	532142965	Pin .5 OD x .43 ID x .750
14	532142939	Arm, Trunnion	62	532142966	Arm, Control
15	532142940	Seal, Lip	63	532142967	Puck, Dampener
17	532142941	Guide, Slot	64	532142920	Set Screw
18	532142988	Shaft, Motor	65	532142968	Bolt #8-32 x .875
19	532142943	Bearing, Thrust 42 x 68 x 16	68	532142969	Spring
23	532142944	Block, Cylinder Assembly	69	532144610	Stud 5/16-24
24	532142945	Seal, Lip 10 x 25 x 7	92	532142977	Spring, Block
25	532142946	Actuator, Bypass	93	532142978	Washer, Block Thrust
26	532142947	Center Section Assembly Kit	98	532142993	Sleeve Bearing
27	532142948	Seal, Lip 26 x 42 x 8	99	532142976	Seal, Wiper
28	532142949	Ring, Retaining	113	532142917	Cap, Vent Assembly
29	532142950	Washer 26 x 35 x 1	114	532142918	Fitting, O-Ring Assembly
34	532142951	Oil Filter Element	119	532142980	Spacer
35	532142952	Arm, Bypass	134	532144607	Nut, Castle 5/16-24
36	532142953	Ring, Retaining	135	532144608	Pin, Cotter
37	532142954	Arm, Actuating			
38	532142955	Pin, Actuating			
39	532142956	Bolt 5/16-24 x 1-3/4			

**NOTE:** All component dimensions given in U.S. inches  
1 inch = 25.4 mm

