

REPAIR PARTS MANUAL

MODEL NO. MB20107HBRK (96061020901)

Lawn Tractor

Mr. Bricolage

HOW TO USE THIS MANUAL

This manual is designed to provide the customer with a means to identify the parts on his/her tractor when ordering repair parts. The illustrations may or may not represent the actual assemblies; therefore, it is not recommended to use this manual as a guide to assemble or disassemble the tractor. Some hardware and parts are drawn larger in order to more readily identify them.

Each tractor has its own model number.

The model number for your tractor can be found on the fender under the seat.

When ordering parts, always give the following information:

- Product - "Tractor"

- Model Number - "MB20107HBRK (96061020901)"
- Part Number
- Part Description

TABLE OF CONTENTS

SCHEMATIC	3
ELECTRICAL.....	4-5
CHASSIS	6-7
DRIVE.....	8-9
STEERING	10-11
SEAT	12
DECALS.....	13
ENGINE.....	14-15
MOWER	16-17
BAGGER.....	18
MOWER LIFT.....	19

TRACTOR - MODEL NO. MB20107HBRK (96061020901), PRODUCT NO. 960 61 02-09 SCHEMATIC

SCH08

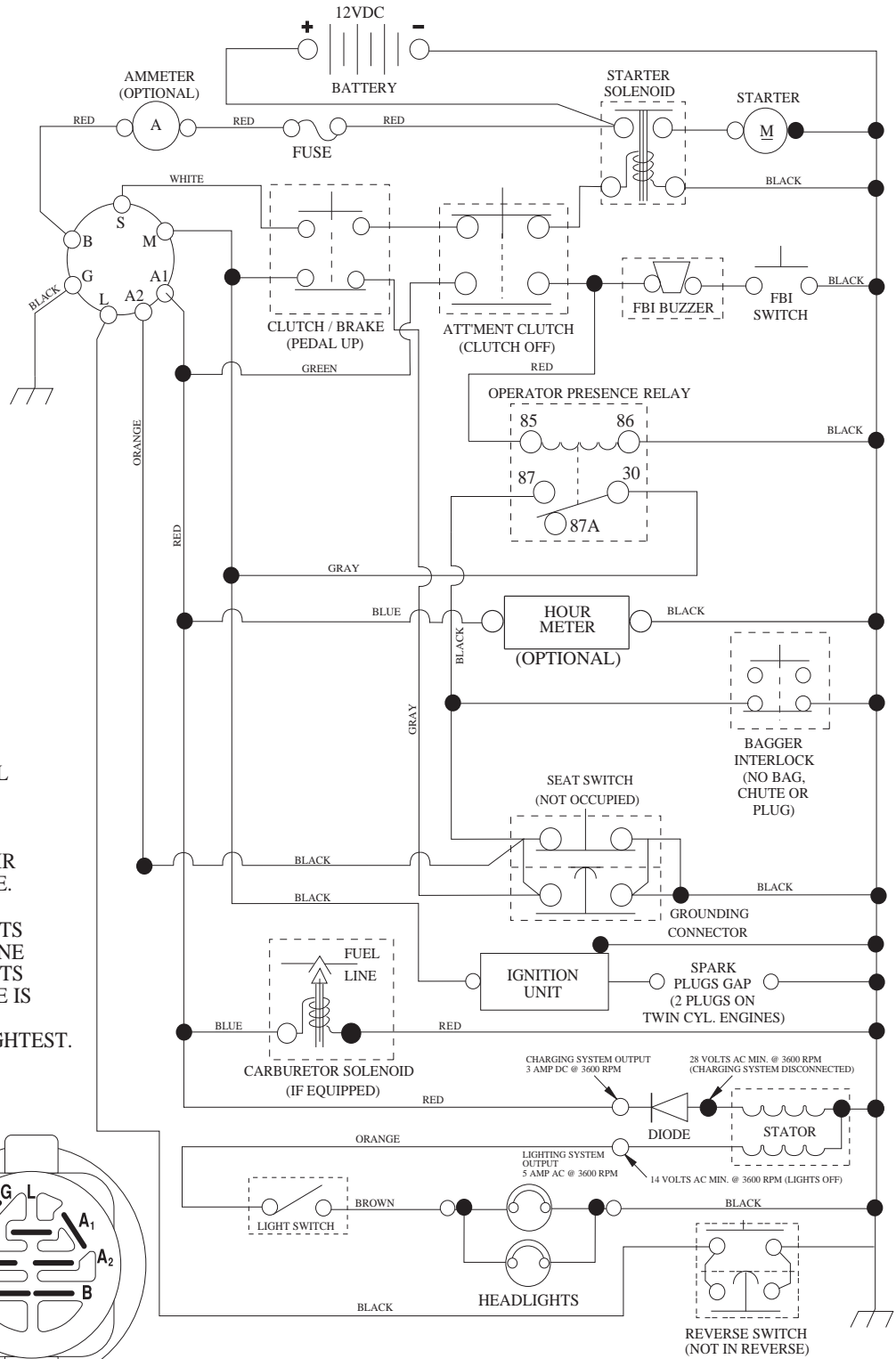

NOTE
YOUR TRACTOR IS EQUIPPED WITH A SPECIAL ALTERNATOR SYSTEM. THE LIGHTS ARE NOT CONNECTED TO THE BATTERY, BUT HAVE THEIR OWN ELECTRICAL SOURCE. BECAUSE OF THIS, THE BRIGHTNESS OF THE LIGHTS WILL CHANGE WITH ENGINE SPEED. AT IDLE THE LIGHTS WILL DIM. AS THE ENGINE IS SPEEDED UP, THE LIGHTS WILL BECOME THEIR BRIGHTEST.

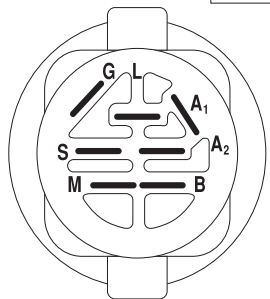

IGNITION SWITCH

POSITION	CIRCUIT	"MAKE"
OFF	M+G+A1	
RUN/OVERRIDE	B+A1	
RUN	B+A1	L+A2
START	B + S + A1	

WIRING INSULATED CLIPS
NOTE: IF WIRING INSULATED CLIPS WERE REMOVED FOR SERVICING OF UNIT, THEY SHOULD BE RE-INSTALLED TO PROPERLY SECURE YOUR WIRING.

REMOVABLE CONNECTIONS
NON-REMOVABLE CONNECTIONS

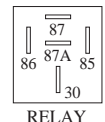

**TRACTOR - MODEL NO. MB20107HBRK (96061020901), PRODUCT NO. 960 61 02-09
ELECTRICAL**

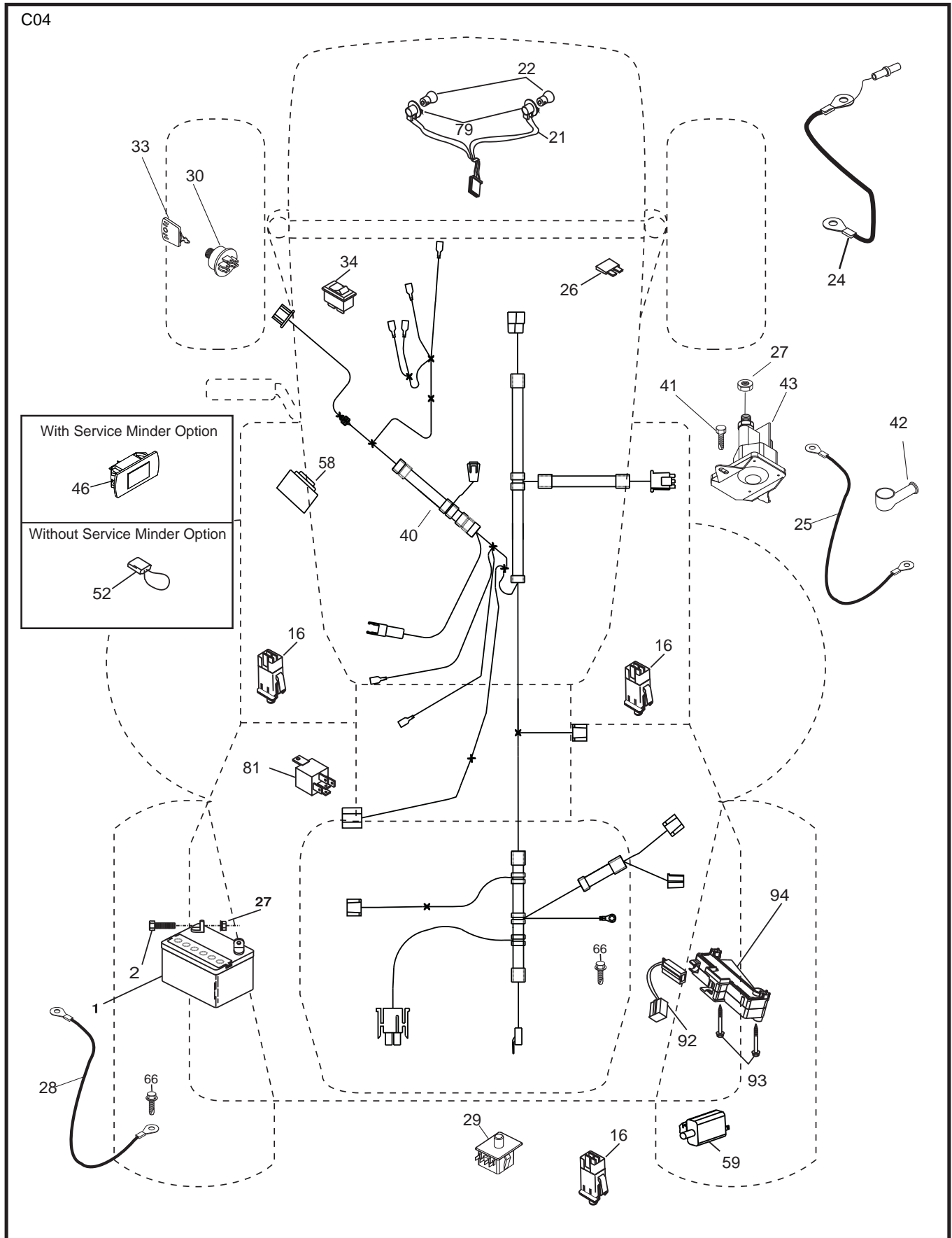

**TRACTOR - MODEL NO. MB20107HBRK (96061020901), PRODUCT NO. 960 61 02-09
ELECTRICAL**

KEY NO.	PART NO.	DESCRIPTION
1	532 14 49-27	Battery
2	874 76 04-12	Bolt Hex Hd 1/4-20 unc x 3/4
16	532 17 61-38	Switch Interlock
21	532 18 37-59	Harness Asm Light w/4152J
22	532 00 41-52	Bulb Light #1156
24	532 12 47-80	Cable Starter 6 Ga. 11" Red
25	532 16 59-87	Cable Battery Crd 56" Red
26	532 17 51-58	Fuse
27	873 51 04-00	Nut Keps Hex 1/4-20 unc
28	532 12 77-25	Cable Ground 6 Ga. 18" Black
29	532 19 27-49	Switch Seat
30	532 19 33-50	Switch Ignition
33	532 41 19-35	Key/Chain
34	532 11 07-12	Switch Light/Reset B/B/Red
40	532 19 74-36	Harness Ign
41	871 11 04-08	Bolt Flk Fin Hex 1/4-20 unc x 1/2
42	532 13 15-63	Cover Terminal Red
43	532 19 25-07	Solenoid
48	532 14 08-44	Adapter Ammeter Rectangular
58	532 16 94-19	Buzzer Crd
59	532 18 03-79	Switch FBI CRD
66	817 49 06-08	Screw Thdrol 3/8-16 x 1/2 Ty-Tt
79	532 17 52-42	Socket Asm Bulb Twistlock
81	532 10 97-48	Relay Asm
92	532 19 66-15	Harness Pigtail Console ROS
93	532 19 25-40	Screw Plastite 10-14 x 2.0
94	532 19 18-34	Module Reverse ROS

NOTE: All component dimensions given in U.S. inches.
1 inch = 25.4 mm.

TRACTOR - MODEL NO. MB20107HBRK (96061020901), PRODUCT NO. 960 61 02-09
CHASSIS AND ENCLOSURES

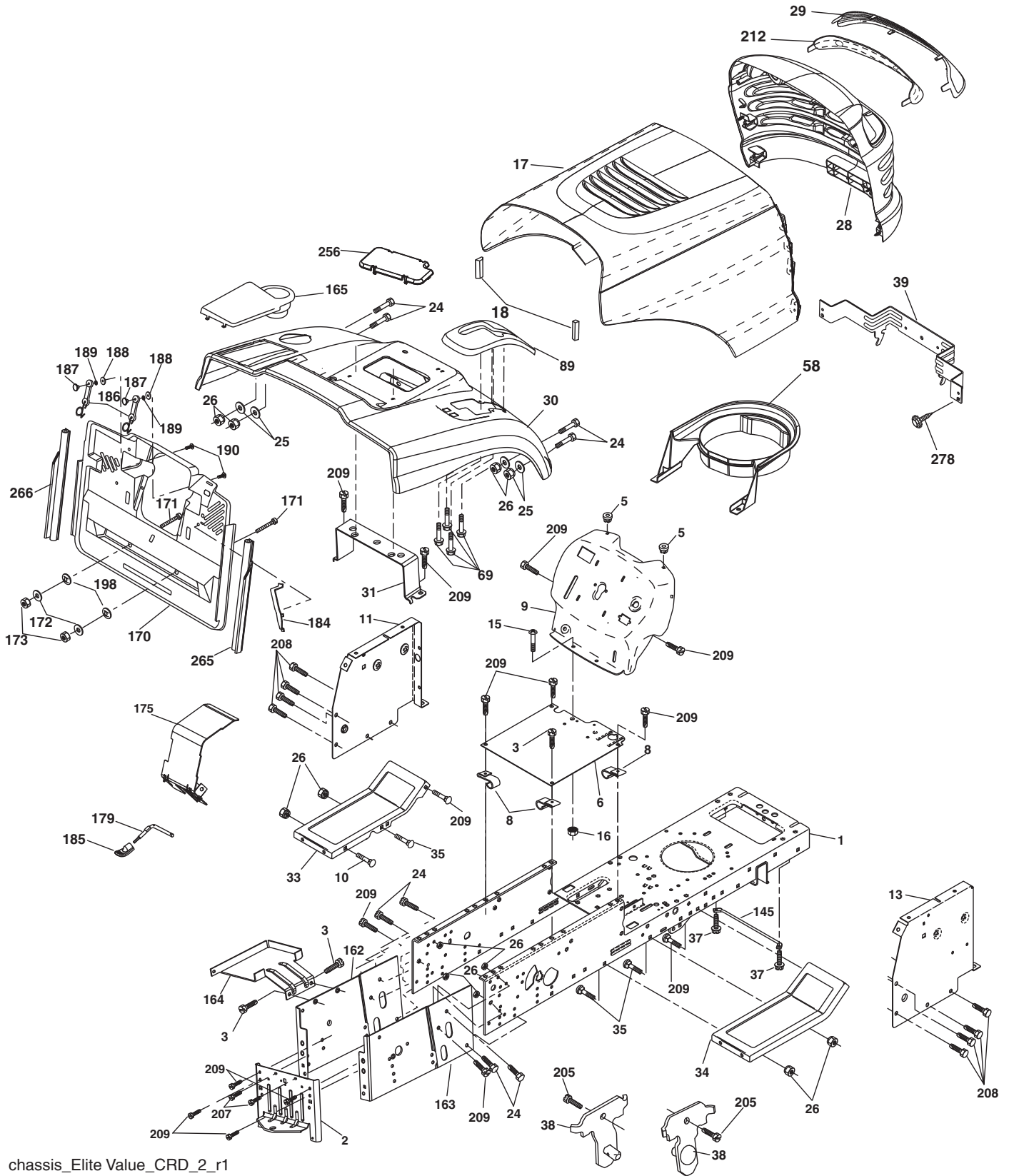

chassis_Elite Value_CRD_2_r1

**TRACTOR - MODEL NO. MB20107HBRK (96061020901), PRODUCT NO. 960 61 02-09
CHASSIS AND ENCLOSURES**

KEY NO.	PART NO.	DESCRIPTION	KEY NO.	PART NO.	DESCRIPTION
1	532 17 46-20	Chassis	162	532 18 03-82	Bracket Exten Chassis LH CRD
2	532 18 03-84	Drawbar	163	532 18 03-83	Bracket Exten Chassis RH CRD
3	817 06 06-12	Screw 3/8-16 x 3/4	164	532 16 56-05	Support Battery CRD
5	532 15 52-72	Bumper Hood/Dash	165	532 18 13-56	Cover Battery
6	532 18 44-19	Saddle	170	532 19 94-88	Backplate CRD
8	532 12 64-71	Clip Insulator 13/32 Mtg. Hole	171	872 14 06-20	Bolt Rdhd Sqnk 3/8-16 x 2-1/2 Gr. 5
9	532 19 46-88	Dash	172	819 13 20-16	Washer 13/32 x 1-1/4 x 16 Ga.
10	872 14 06-08	Bolt, Carriage 3/8-16 x 3/4	173	873 51 06-00	Nut, Keps Hex 3/8-16 unc
11	532 17 49-96	Panel, Dash, L.H.	175	532 18 82-03	Guard Trap
13	532 18 69-52	Panel, Asm. Dash R.H.	179	532 18 82-02	Rod Pivot FBI CRD
15	874 18 05-12	Screw, Machine, Truss Head 5/16-18 unc x 3/4	184	532 17 46-62	Bracket Actuator Bagger CRD
16	873 51 05-00	Nut	185	532 18 11-01	Knob Rod Brake Parking
17	532 19 00-85	Hood	186	532 16 07-93	Latch Asm Mulch/Bagger
18	532 18 49-21	Bumper Hood	187	532 12 50-04	Nut Weld
24	874 78 06-16	Bolt	188	819 06 12-16	Washer #10
25	819 13 13-12	Washer 13/32 x 13/16 x 12 Ga.	189	810 07 10-00	Washer Lock #10
26	873 80 06-00	Nut	190	871 08 10-10	Screw Pan Hd Phillip 10-24 x 5/8
28	532 18 35-52	Grille w/Lens Asm	198	532 16 89-37	Nut, Push
29	532 18 58-46	Lens Grille Value Bar LT Clear	205	817 49 06-08	Screw Thdrol 3/8-16 x 1/2
30	532 40 37-00	Fender	207	817 67 05-08	Screw Thdrol 5/16-18 x 1/2
31	532 16 51-56	Bracket, Fender Support	208	817 67 06-08	Screw Thdrol 3/8-16 x 1/2
33	532 18 55-45	Footrest, L.H.	209	817 00 06-12	Screw Hex Wsh Thdrol 3/8-16
34	532 18 55-46	Footrest, R.H.	212	532 18 35-50	Insert Lens Refl.
35	872 11 06-06	Bolt	256	532 18 13-61	Cover Fender Rack
37	817 49 05-08	Screw Thdrol 5/16-18 x 1/2 TYT	265	532 18 57-04	Seal Side RH Bagger
38	532 18 17-48	Bracket Asm Pivot Mower Rear	266	532 18 57-03	Seal Side LH Bagger
39	532 40 78-07	Bracket Pivot Laser LT	278	532 41 63-58	Screw #10 x 0.750 BOS
58	532 18 44-62	Airduct Intake	--	532 00 54-79	Plug Btn Blk
69	532 14 24-32	Screw Hx Wsh Hi-Lo 1/4-1/2			
89	532 19 73-66	Console Crd Auto			
145	532 40 91-67	Rod Pivot Chassis/Hood			

NOTE: All component dimensions given in U.S. inches.
1 inch = 25.4 mm.

TRACTOR - MODEL NO. MB20107HBRK (96061020901), PRODUCT NO. 960 61 02-09
DRIVE

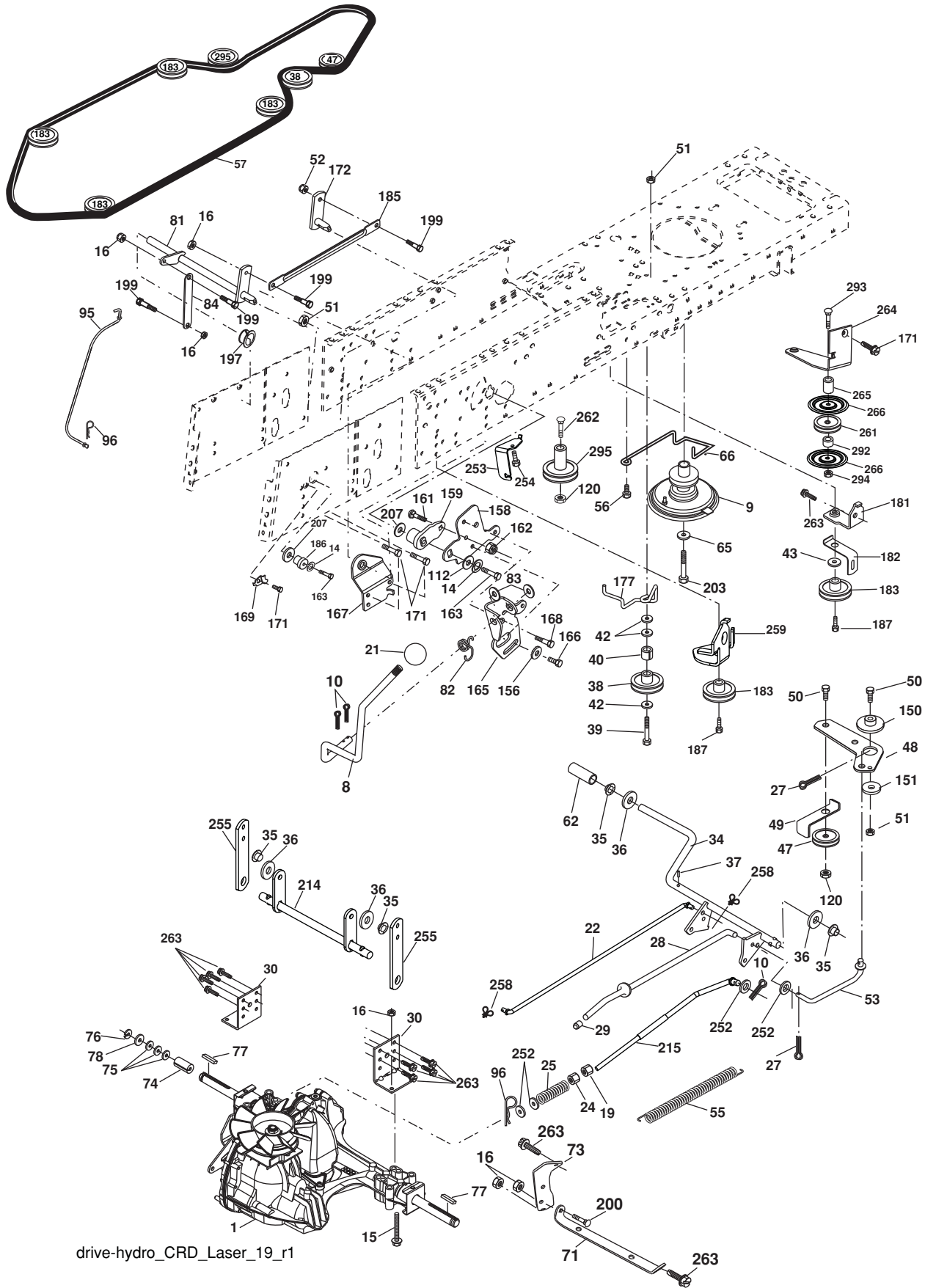

drive-hydro_CRD_Laser_19_r1

**TRACTOR - MODEL NO. MB20107HBRK (96061020901), PRODUCT NO. 960 61 02-09
DRIVE**

KEY NO.	PART NO.	DESCRIPTION	KEY NO.	PART NO.	DESCRIPTION
1	-----	Transaxle Hydro Gear 321-0510 (Order parts from transaxle manufacturer)	112	819 09 12-10	Washer 9/32 x 3/4 x 10 Ga.
8	532 19 27-06	Rod, Shift Fender	120	873 90 06-00	Nut Lock Flg. 3/8-16 unc
9	532 40 85-79	Clutch Asm Noram	150	532 16 58-50	Bushing, Bellcrank Grnd Dr
10	876 02 04-16	Pin, Cotter 1/8 x 1	151	819 13 32-10	Washer 13/32 x 2 x 10 Ga.
14	810 04 04-00	Washer, Lock Hvy Helical	156	532 16 60-02	Washer Srrted 5/16ID x 1.125
15	874 49 05-44	Bolt Hex FGHD 5/16-18 x Gr. 5	158	532 16 55-89	Bracket Shift Mount
16	873 80 05-00	Nut Lock Hex w/lns 5/16-18 unc	159	532 18 39-00	Hub Tapered Flange Shift Lt
19	873 80 06-00	Nut Lock Hex w/lns 3/8-16 unc	161	872 14 04-06	Bolt Rdhd Sqnk 1/4-20 x 3/4 Gr. 5
21	532 10 69-33	Knob	162	873 68 04-00	Nut Crownlock 1/4-20 unc
22	532 17 56-07	Rod, Brake	163	874 78 04-16	Bolt Hex Fin 1/4-20 unc x 1 Gr. 5
24	873 35 06-00	Nut	165	532 16 56-23	Bracket Pivot Lever
25	532 19 20-36	Spring, Rod, Brake	166	817 49 05-10	Screw 5/16-18 x 5/8
27	876 02 04-12	Pin, Cotter 1/8 x 3/4	167	532 16 55-88	Bracket Support Shift CRD
28	532 17 57-65	Rod, Parking Brake	168	532 16 54-92	Bolt Shoulder 5/16-18 x .561
29	532 07 16-73	Cap, Parking Brake	169	532 16 55-80	Plate Fastening Lt
30	532 16 95-92	Bracket, Mfg. Transaxle	171	817 49 06-08	Screw Thdrol 3/8-16 x 1/2 Ty-Tt
34	532 17 55-78	Shaft, Asm Pedal Foot CRD	172	532 17 02-71	Shaft Asm Shifter Frt CRD
35	532 12 01-83	Bearing, Nylon	177	532 16 59-32	Keeper Flat Idler 3.06" CRD
36	819 21 16-16	Washer 21/32 x 1 x 16 Ga.	181	532 18 02-11	Bracket Idler Ground Drive CRD
37	532 12 49-63	Pin, Roll 3/16 x 1"	182	532 18 26-82	Keeper Belt 2.5" Od V-Idler CRD
38	532 16 59-36	Pulley Flat Composite 3.06"	183	532 19 95-32	Pulley V-Idler
39	874 76 06-44	Bolt Fin Hex 3/8-16 unc x 2-3/4	185	532 17 00-08	Link Shift
40	532 12 49-65	Spacer, Split 395 x 59 Bzp	186	532 16 56-14	Hub Tapered Round CRD
42	819 13 13-12	Washer 13/32 x 13/16 x 12 Ga.	187	817 58 05-20	Screw Thdrol 5/16-18 x 1.25
43	819 11 10-12	Washer 11/32 x 5/8 x 12 Ga.	197	532 16 96-13	Nyliner Snap-In 5/8
47	532 12 77-83	Pulley, Idler, V Groove Plastic	199	532 16 96-12	Bolt Shoulder 5/16-18 unc
48	532 15 44-07	Bellcrank Clutch Grnd Drv	200	872 14 05-08	Bolt RDHD SQNK 5/16-18 x 1
49	532 12 32-05	Retainer, Belt Style Spring	203	871 17 07-80	Bolt Hex 7/16-20 x 5
50	872 11 06-12	Bolt, Carr. Sh. 3/8-16 x 1-1/2 Gr. 5	207	532 16 98-45	Washer Nylon Rear
51	873 68 06-00	Nut, Crownlock 3/8-16 unc	214	532 17 56-09	Shaft Asm. Brake
52	873 68 05-00	Nut Crownlock 5/16-18	215	532 17 56-52	Rod Brake Hydro
53	532 19 96-52	Link, Clutch 7.66	252	819 13 16-16	Washer 13/32 x 1 16 Ga.
55	532 10 57-09	Spring, Return, Clutch	253	532 17 50-28	Bracket Cable Chassis
56	817 06 06-20	Screw 3/8-16 x 1-1/4	254	817 00 06-16	Screw 3/8-16 x 1
57	532 17 01-40	V-Belt Kev 112" 0650 CRD	255	532 17 56-08	Brace Shaft Brake Mtg.
62	532 12 48-72	Cover, Pedal	258	532 17 80-62	Clip Retainer
65	810 04 07-00	Washer	259	532 18 02-12	Bracket Pulley
66	532 15 47-78	Keeper, Belt Engine F-Proof	261	532 13 14-94	Pulley Idler
71	532 16 91-83	Strap, Torque, LH	262	872 11 06-22	Bolt Rdhd 3/8-16 unc x 2-3/4 Cat. 5
73	532 16 91-82	Strap, Torque, RH	263	817 00 06-12	Screw 3/8-16 x 3/4
74	532 13 70-57	Spacer, Split	264	532 19 76-08	Bracket Idler
75	532 12 17-49	Washer 25/32 x 1-1/4 x 16 Ga.	265	532 40 46-07	Spacer Idler Chassis
76	812 00 00-01	Ring, E	266	532 18 20-61	Shield Idler Mower
77	532 12 35-83	Key, Square	292	532 40 02-71	Spacer Noram
78	532 12 17-48	Washer 25/32 x 1-5/8 x 16 Ga.	293	872 14 06-28	Bolt Rdhd Sqnk 3/8-16 x 3-1/2
81	532 17 00-06	Asm, Shaft,Cross Rear	294	532 19 70-33	Nut Jam 3/8-16
82	532 16 57-11	Spring, Torsion	295	532 17 91-14	Pulley Idler Composite
83	819 17 12-16	Washer 17/32 x 3/4 x 16 Ga.			
84	532 17 00-07	Link, Transaxle			
95	532 17 00-15	Control Asm Bypass Hydro			
96	532 12 47-88	Spring, Retainer 1"			

NOTE: All component dimensions given in U.S. inches
1 inch = 25.4 mm

TRACTOR - MODEL NO. MB20107HBRK (96061020901), PRODUCT NO. 960 61 02-09
STEERING ASSEMBLY

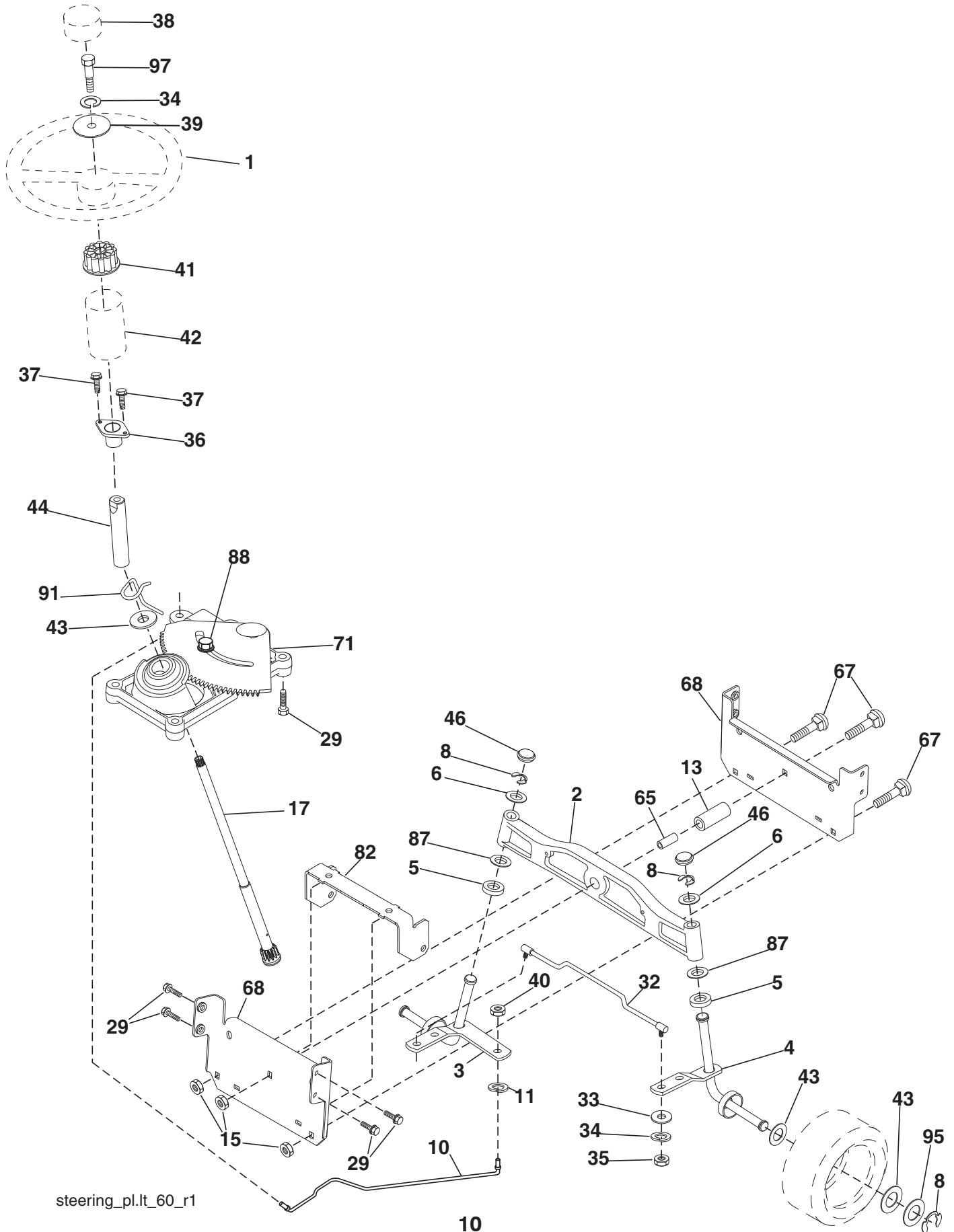

steering_pl.lt_60_r1

**TRACTOR - MODEL NO. MB20107HBRK (96061020901), PRODUCT NO. 960 61 02-09
STEERING ASSEMBLY**

KEY NO.	PART NO.	DESCRIPTION
1	532 18 67-80	Steering Wheel
2	532 18 47-06	Front Axle Assembly
3	532 16 98-40	Spindle Assembly, L.H.
4	532 16 98-39	Spindle Assembly, R.H.
5	532 12 49-31	Bearing, Race, Thrust, Hardened
6	532 12 17-48	Washer 25/32 x 1-5/8 x 16 Ga.
8	812 00 00-29	Ring, Clip
10	532 17 51-21	Link, Drag
11	810 04 06-00	Washer, Lock
13	532 13 65-18	Spacer Axle
15	532 14 52-12	Nut Hex Flange Lock
17	532 19 07-53	Shaft Assembly, Steering
29	817 00 06-12	Screw 3/8-16 x 3/4
32	532 17 01-62	Rod, Tie
33	819 11 12-16	Washer 11/32 x 3/4 x 16 Ga.
34	810 04 05-00	Washer Lock Hvy Hlcl Spr 5/16
35	873 54 05-00	Crownlock Nut 5/16-24 unc
36	532 15 50-99	Bushing, Steering
37	532 15 29-27	Screw TT #10-32 x 5 x 3/8 Flange
38	532 19 29-16	Cap Wheel Steering
39	819 11 38-12	Washer 11/32 ID x 2-3/8 12 Ga.
40	873 54 06-00	Nut Crownlock 3/8-24
41	532 18 67-37	Adaptor, Steering Wheel
42	532 16 96-33	Boot, Steering Dash P/L Mtl
43	532 12 17-49	Washer 25/32 x 1-1/4 x 16 Ga.
44	532 19 07-52	Extension Steering
46	532 12 12-32	Cap, Spindle
65	532 41 47-36	Spacer Axle
67	872 11 06-18	Bolt Rdhd Sq 3/8-16 x 2-1/4
68	532 16 98-27	Brace Axle
71	532 17 51-46	Steering Asm.
82	532 19 99-78	Bracket Susp. Chassis Front
87	532 17 39-66	Washer Flat .781 x 1-1/2 x .14
88	532 17 51-18	Bolt Shoulder 7/16-20 unc
91	532 17 55-53	Clip Steering
95	532 18 89-67	Washer Harden
97	874 78 05-64	Bolt 5/16-18 unc x 4"L Gr. 5

NOTE: All component dimensions given in U.S. inches.
1 inch = 25.4 mm.

**TRACTOR - MODEL NO. MB20107HBRK (96061020901), PRODUCT NO. 960 61 02-09
SEAT ASSEMBLY**

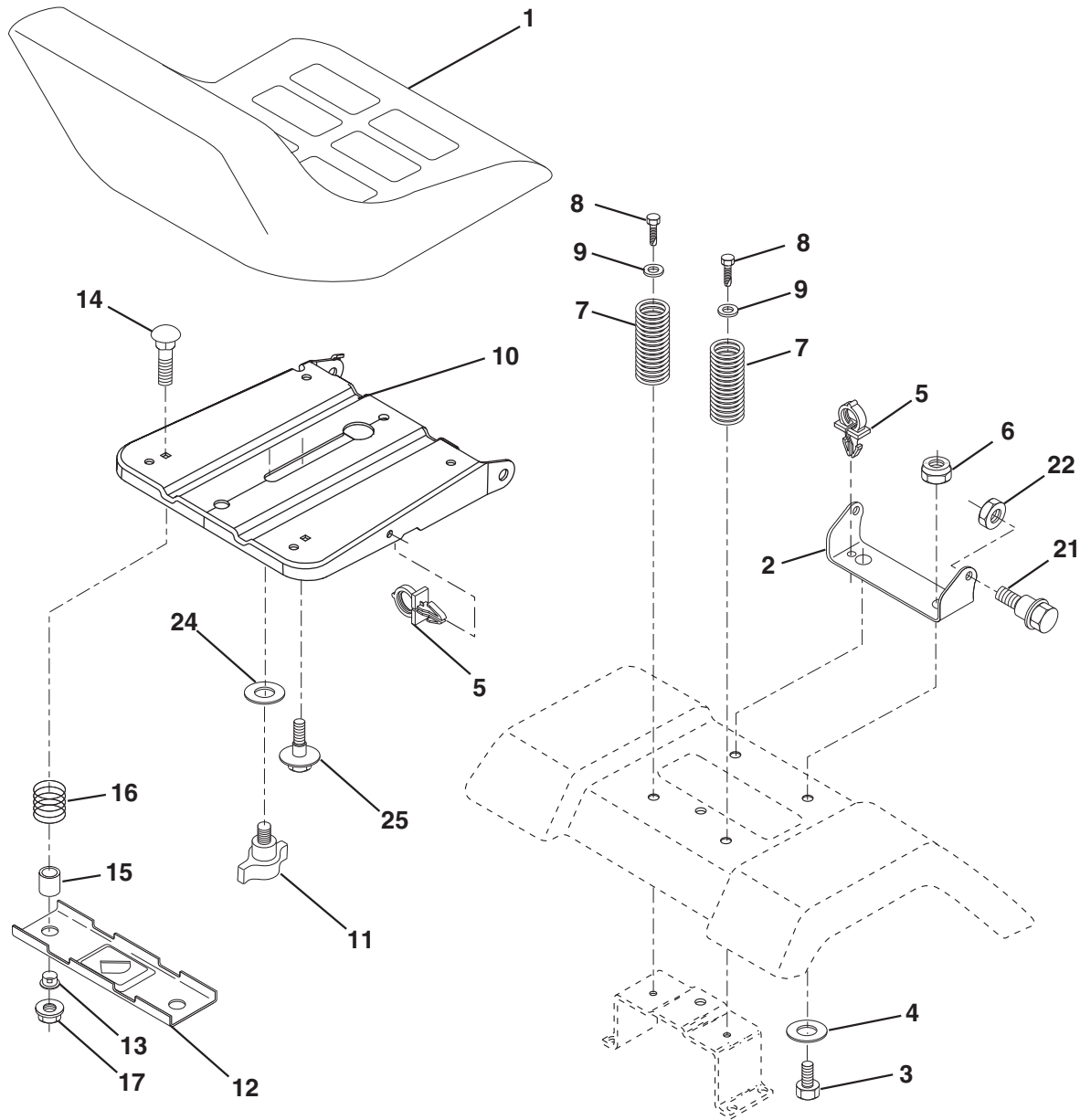

seat_it.knob_13

KEY NO.	PART NO.	DESCRIPTION
1	532 18 87-13	Seat
2	532 14 05-51	Bracket Pnt Pivot Seat (Blk)
3	871 11 06-16	Bolt Fin Hex 3/8-16 x 1
4	819 13 16-10	Washer Flat 13/32 x 1 x 10 Ga.
5	532 14 50-06	Clip Push In Hinged
6	873 80 06-00	Nut Lock Hex w/Ins 3/8-16
7	532 12 41-81	Spring Seat Cprsn 2 250 Blk Zi
8	817 00 06-16	Screw 3/8-16 x 1.5
9	819 13 16-14	Washer 13/32 x 1 x 14 Ga.
10	532 19 55-30	Pan Pnt Seat (Blk)
11	532 16 63-69	Knob Seat
12	532 17 46-48	Bracket Pnt Mounting Switch

KEY NO.	PART NO.	DESCRIPTION
13	532 12 12-48	Bushing Snap Blk Nyl 50 Id
14	872 05 04-12	Bolt Rdhd Sht Nk 1/4-20 x 1-1/2
15	532 13 43-00	Spacer Split
16	532 12 12-50	Spring Cprsn
17	532 12 39-76	Nut Lock 1/4 Lge Flg Gr. 5 Zinc
21	532 17 18-52	Bolt Shoulder 5/16-18 unc-2A
22	873 80 05-00	Nut Hex Lock w/Ins 5/16-18
24	819 17 19-12	Washer 17/32 x 1-3/16 x 12 Ga.
25	532 12 70-18	Bolt Shoulder 5/16-18 x .62

NOTE: All component dimensions given in U.S. inches.
1 inch = 25.4 mm

**TRACTOR - MODEL NO. MB20107HBRK (96061020901), PRODUCT NO. 960 61 02-09
DECALS**

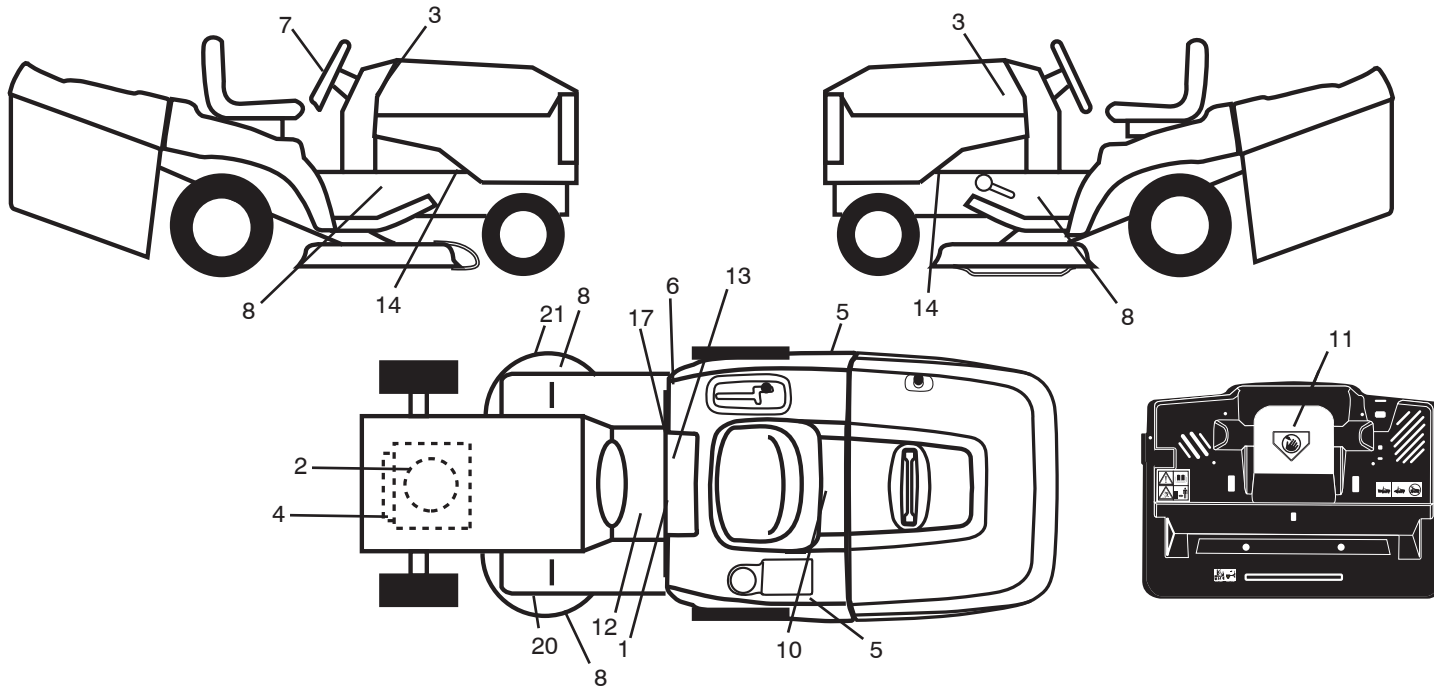

KEY NO.	PART NO.	DESCRIPTION	KEY NO.	PART NO.	DESCRIPTION
1	532 40 03-89	Decal, Warning Syms. CE	12	532 15 97-37	Decal, Brake/Clutch Symbol Lt
2	532 40 97-13	Decal, Hp Engine	13	532 16 69-60	Decal, Bypass
3	532 17 16-68	Decal, Hood	14	532 15 97-36	Decal Chassis Hot Muffler
4	532 19 68-41	Decal, Warning Eng. Syms.	17	532 14 08-37	Decal Saddle Brake Parking
5	532 41 00-76	Decal, Fender Sd.	20	532 18 78-11	Decal Enviro Deck
6	532 18 04-32	Decal, 100 DBA	21	532 16 62-86	Decal Deck Sch 92 CRD
7	532 16 79-70	Decal, Ins Strg Whl	--	532 13 83-11	Decal Lift Handle
8	532 19 68-42	Decal, Sdl Shf/CRD Sym Cutfinger	--	532 18 04-35	Decal, Plate Rear
10	532 14 50-05	Decal, Bat Dan/Poi P/L Sym Wpn	--	532 40 08-65	Manual Operator's (Euro)
11	532 18 21-66	Decal, Mower Cut Finger CE	--	532 41 70-68	Manual Parts

WHEELS & TIRES

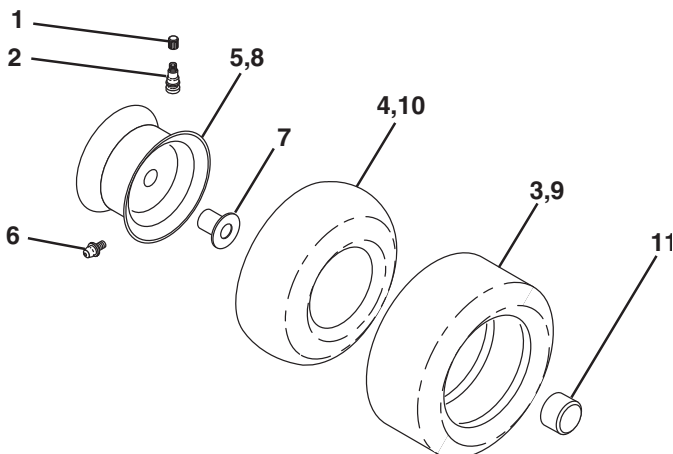

KEY NO.	PART NO.	DESCRIPTION
1	532 05 91-92	Cap Valve Tire
2	532 06 51-39	Stem Valve
3	532 10 62-22	Tire F Ts 15 x 6 0 - 6 Service
4	532 05 99-04	Tube Inner Front #35060
5	532 18 33-37	Rim Asm 6" Front Service
6	532 12 49-57	Fitting Grease
7	532 12 49-59	Bearing Flange
8	532 18 33-38	Rim Asm 8" Rear Service
9	532 13 84-68	Tire R Ts 20 x 8-8 C. Service
10	532 12 49-26	Tube Rear 9 5 x 8 Service
11	532 17 50-39	Cap Axle Blk 1 50 x 1 00
--	532 14 43-34	Sealant, Tire (10 oz. Tube)

NOTE: All component dimensions given in U.S. inches
1 inch = 25.4 mm

**TRACTOR - MODEL NO. MB20107HBRK (96061020901), PRODUCT NO. 960 61 02-09
ENGINE**

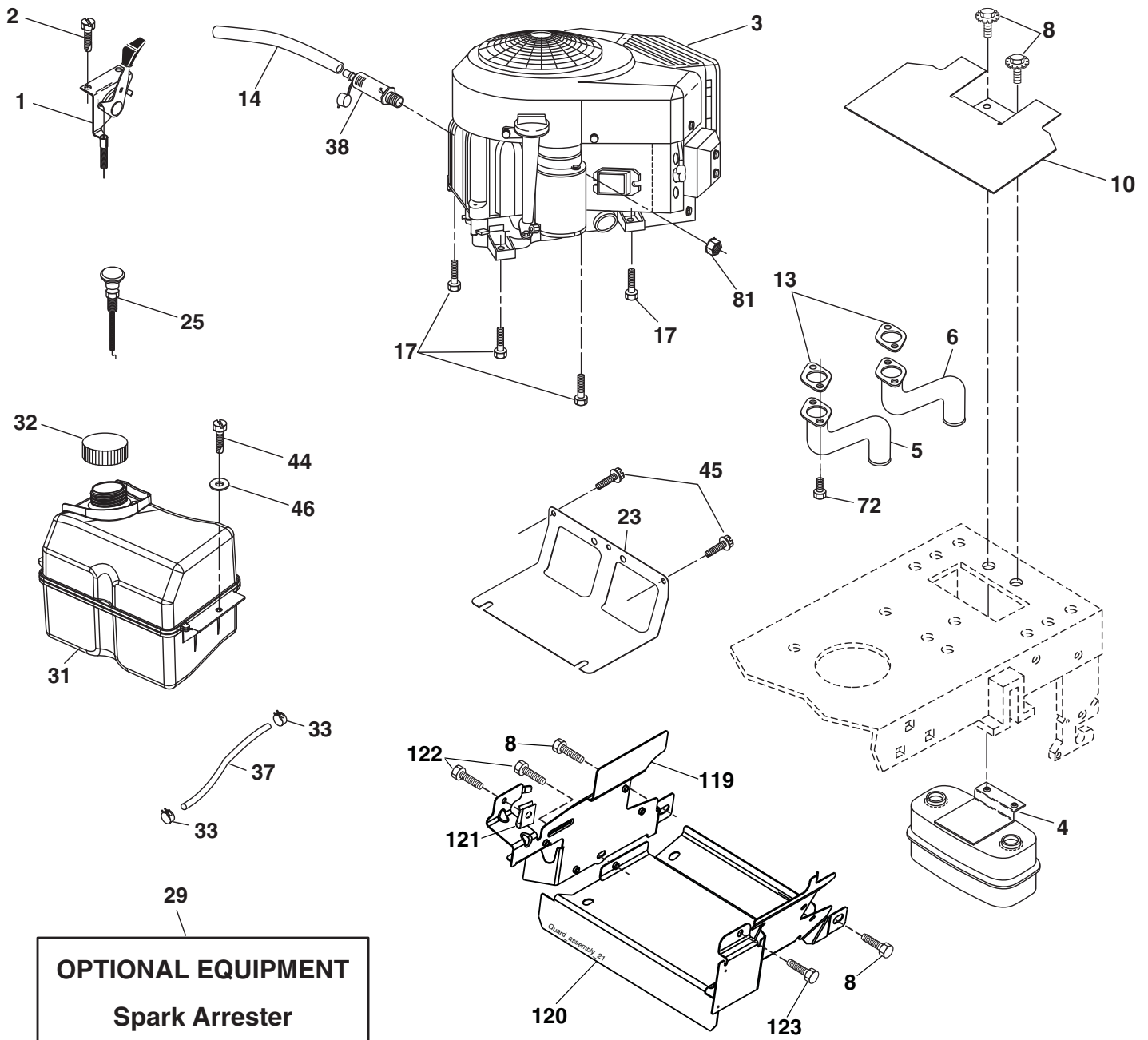

engine-bs intek-twin_43_r1

TRACTOR - MODEL NO. MB20107HBRK (96061020901), PRODUCT NO. 960 61 02-09 ENGINE

KEY NO.	PART NO.	DESCRIPTION
1	532 17 07-71	Control Throt/Ck
2	817 72 04-08	Screw Hex Thd Cut 1/4-20 x 1/2
3	-----	Engine B&S Model 406777-0803-E1 (Order parts from engine manufacturer)
4	532 14 97-23	Muffler
5	532 15 99-55	Exhaust Tube LH
6	532 16 05-89	Exhaust Tube RH
8	532 17 18-77	Bolt 5/16-18 unc x 3/4 w/Sems
10	532 14 66-29	Shield Heat
13	532 16 53-91	Gasket Muffler
14	532 14 84-56	Tube Drain Oil Easy
17	817 06 06-20	Screw 3/8-16 x 1/4
23	532 16 98-37	Shield Brn/Dbr Guard
25	532 19 18-12	Control Choke
29	532 13 71-80	Kit Spark Arrester (Flat Scrn)
31	532 40 75-51	Tank Fuel
32	532 19 77-25	Cap Asm Fuel
33	532 12 34-87	Clamp Hose Blk
37	532 13 70-40	Line Fuel
38	532 18 16-54	Plug Drain Oil Easy
44	817 67 04-12	Screw Hexwsh Thdrol 1/4-20 x 3/4
45	817 00 06-12	Screw Hexwsh Thdr 3/8-16 x 3/4
46	819 09 14-16	Washer 9/32 x 7/8 x 16 Ga.
72	532 18 39-06	Screw Socket Hd 5/16-18 x 1
81	873 51 04-00	Nut Keps Hex 1/4-20 unc
119	532 19 97-68	Guard Asm Eng. LH
120	532 19 97-67	Guard Asm Eng. RH
121	532 19 66-88	Clips Threaded
122	532 13 77-29	Screw Thd Roll 1/4-20 x 5/8
123	817 67 05-08	Screw Thdrol 5/16-18 x 1/2
122	532 13 77-29	Screw Thd. Roll 1/4-20 x 5/8

NOTE: All component dimensions given in U.S. inches
1 inch = 25.4 mm

Engine Power Rating Information

The gross power rating for individual gas engine models is labeled in accordance with SAE (Society of Automotive Engineers) code J11940 (Small Engine Power & Torque Rating Procedure), and rating performance has been obtained and corrected in accordance with SAE J1995 (Revision 2002-5). Actual gross engine power will be lower and is affected by, among other things, ambient operating conditions and engine-to-engine variability. Given both the wide array of products on which engines are placed and the variety of environmental issues applicable to operating the equipment, the gas engine will not develop the rated gross power when used in a given piece of power equipment (actual "on-site" or net horsepower). This difference is due to a variety of factors including, but not limited to, accessories (air cleaner, exhaust, charging, cooling, carburetor, fuel pump, etc.), application limitations, ambient operating conditions (temperature, humidity, altitude), and engine-to-engine variability. Due to manufacturing and capacity limitations, Briggs & Stratton may substitute an engine of higher rated power for this Series engine.

**TRACTOR - MODEL NO. MB20107HBRK (96061020901), PRODUCT NO. 960 61 02-09
MOWER**

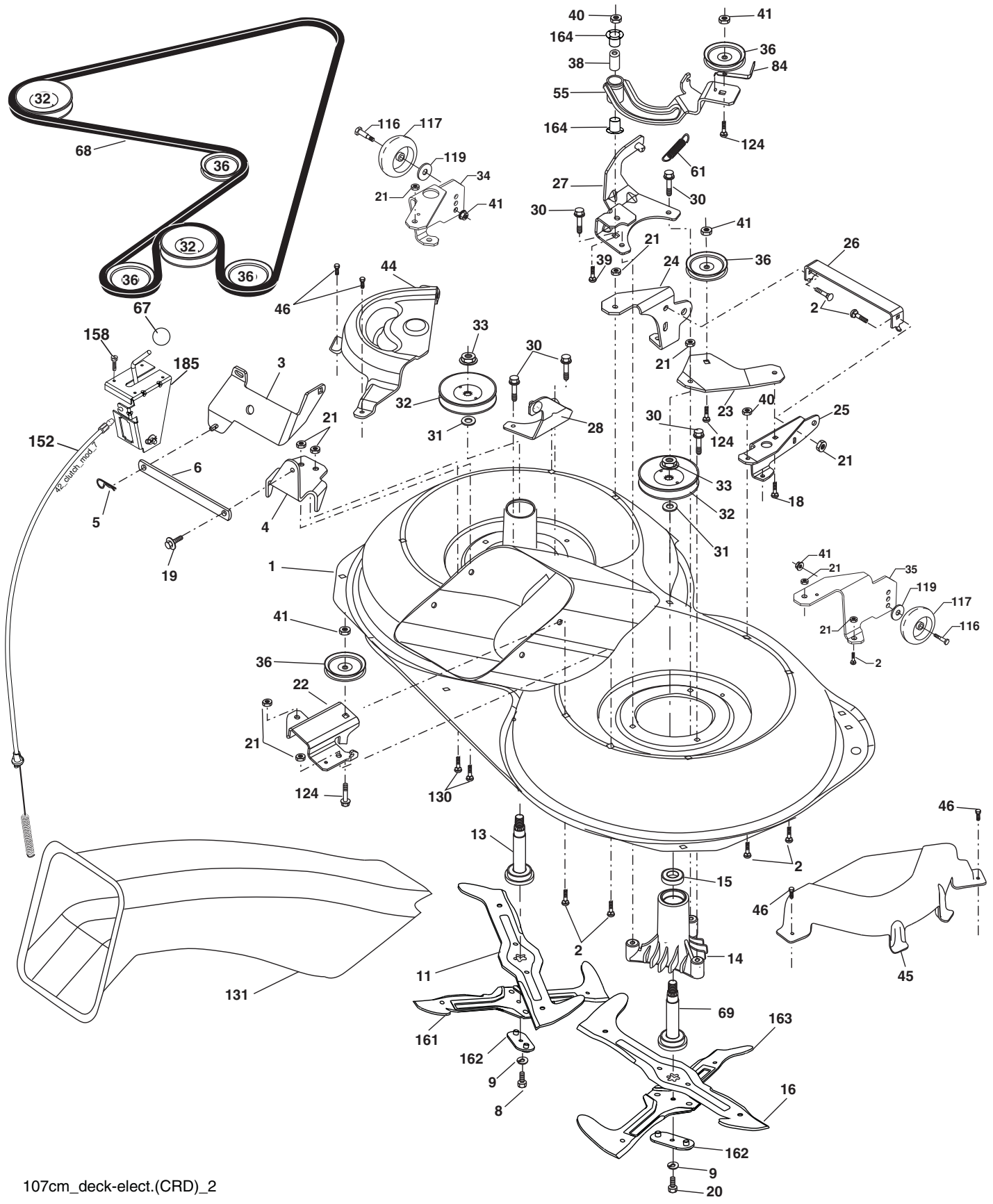

107cm_deck-elect.(CRD)_2

**TRACTOR - MODEL NO. MB20107HBRK (96061020901), PRODUCT NO. 960 61 02-09
MOWER**

KEY NO.	PART NO.	DESCRIPTION	KEY NO.	PART NO.	DESCRIPTION
1	532 16 91-60	Housing Asm. Mower	41	873 90 06-00	Nut Lock Flg. 3/8-16 unc
2	872 14 05-06	Bolt Rdhd Sqnk 5/16-18 unc x 3/4	44	532 17 55-38	Cover Mandrel LH
3	532 16 55-69	Bracket Asm. S-Bar Chass	45	532 17 55-39	Cover Mandrel RH
4	532 16 91-67	Bracket Bar Sway Deck	46	532 13 77-29	Screw Thd Roll 1/4-20 x 5/8
5	532 12 46-70	Retainer Spring	55	532 16 98-49	Arm Idler
6	532 16 55-57	Bar Sway	61	532 19 94-87	Spring Tension Belt
8	532 18 17-12	Bolt 3/8-24 x 1.25 Gr. 8 Patched	67	532 10 69-32	Knob
9	810 03 06-00	Washer Lock Hvy 3/8 Unplated	68	532 40 20-09	Hex-Belt
11	532 18 05-83	Blade 3-1 LH	69	532 16 54-82	Shaft Asm w/Lwr Brg RH Thd CRD
13	532 13 76-45	Shaft Asm. w/Lower Bearing	84	532 15 60-85	Keeper Belt Idler
14	532 12 87-74	Housing mandrel Vented (Machd)	116	532 19 34-06	Bolt Shoulder
15	532 11 04-85	Bearing Ball Mandrel	117	532 17 48-73	Wheel Gauge
16	532 18 05-84	Blade 3-1 RH	118	873 90 06-00	Nut Centerlock 3/8-16 unc
18	872 11 06-06	Bolt Rdhd Sqnk 3/8-16 x 3/4	119	819 13 20-12	Washer 13/32 x 1-1/4 x 12
19	532 13 28-27	Bolt Shoulder 5/16-18 Thd Form	124	872 11 06-12	Bolt Carr Sh 3/8-16 x 1-1/2 Gr. 5
20	532 18 17-13	Bolt 3/8-24 x 1.25 Gr. 8 Ptch Lhthd	130	872 11 05-06	Bolt Rdhdsqnk 5/16-18 unc x 3/4
21	873 68 05-00	Nut Crown Lock 5/16-18	131	532 16 56-61	Chute Bagger CRD 92cm
22	532 16 91-65	Bracket Idler Sprr RR	152	532 17 60-74	Cable Clutch
23	532 16 91-66	Bracket Idler Sprr RF	158	817 72 04-08	Screw Thd Cut 1/4-20 x 1/2
24	532 41 34-36	Bracket Suspension LF	161	532 18 04-24	Blade Cross LH
25	532 40 01-05	Bracket Suspension RF	162	532 18 08-78	Adapter
26	532 40 01-10	Brace Support Susp Frr	163	532 18 04-25	Blade Cross RH
27	532 16 91-72	Bracket Asm. Susp RR	164	532 12 49-37	Bearing Col. Strg
28	532 16 91-68	Bracket Asm. Susp LR	185	532 18 82-34	Head Asm Cable Clutch
30	532 17 39-84	Screw Thd Rolling	--	532 18 18-57	Mandrel Assembly (Includes housing, shaft assembly, and bearing only - pulley/nut/washer and blade bolt/washers not included)
31	532 18 76-90	Washer Spacer	--	532 18 18-58	Mandrel Asm CRD LH Threads SVC
32	532 19 81-45	Mandrel Pulleys	--	532 40 03-25	Replacement Mower Complete (Order separately gauge wheel components key numbers 116-119)
33	532 40 02-34	Nut Flg Top Lock			
34	532 40 01-03	Bracket Gauge Wheel LF			
35	532 40 01-04	Bracket Gauge Wheel RF			
36	532 14 67-63	Pulley Idler V-Groove Dim 4.25			
38	532 16 98-51	Spacer Hub			
39	872 11 06-22	Bolt RDHD 3/8-16 unc x 2-3/4 Gr. 5			
40	873 68 06-00	Nut Crownlock 3/8-16 unc			

NOTE: All component dimensions given in U.S. inches
1 inch = 25.4 mm

**TRACTOR - MODEL NO. MB20107HBRK (96061020901), PRODUCT NO. 960 61 02-09
BAGGER**

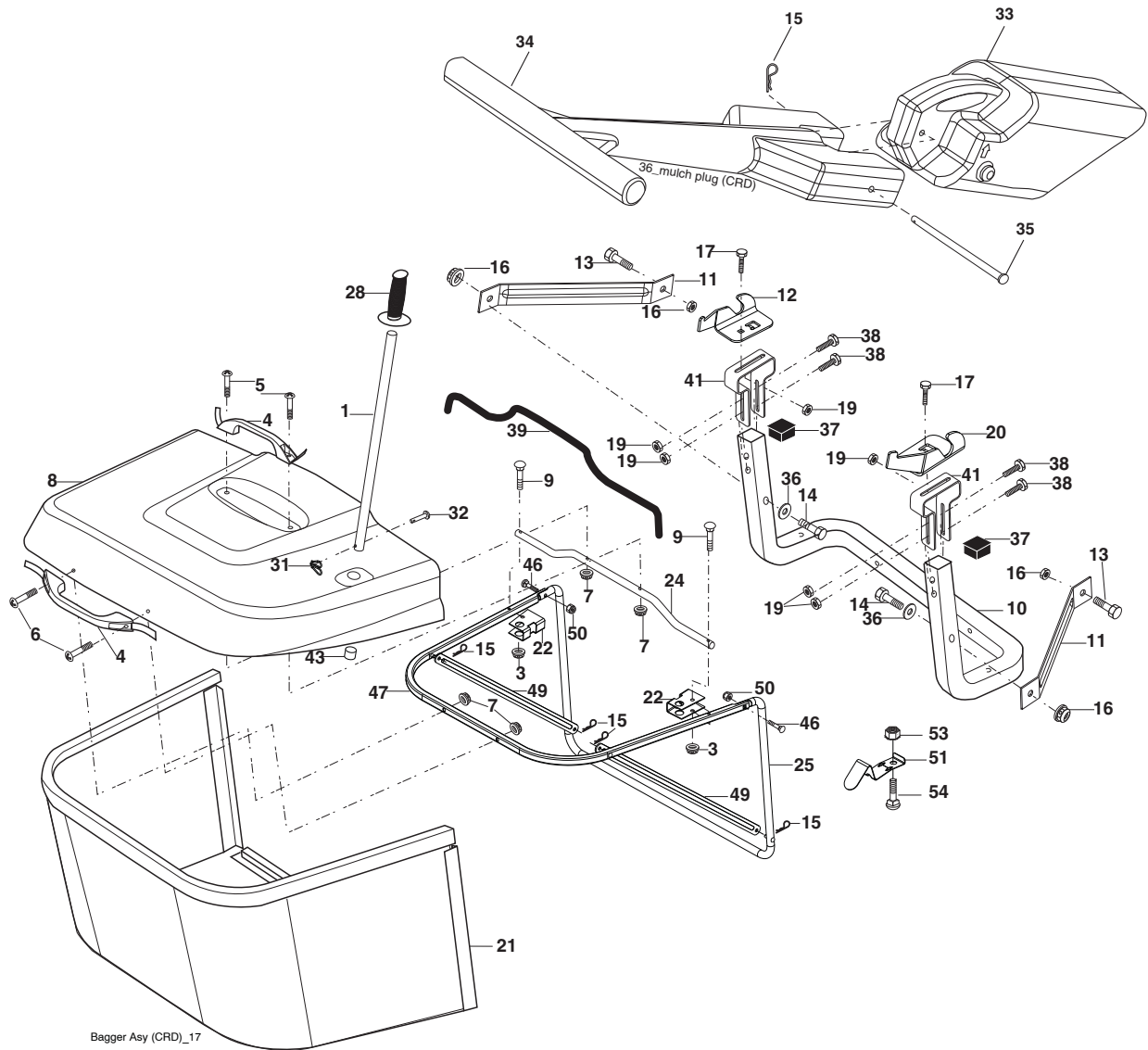

KEY NO.	PART NO.	DESCRIPTION	KEY NO.	PART NO.	DESCRIPTION
1	532 16 52-49	Tube Handle Bagger CRD	28	532 16 57-87	Grip Handle
3	532 12 39-76	Nut Lock 1/4 Lge Flg Gr. 5 Zinc	31	532 16 94-84	Retainer Clip
4	532 16 99-16	Handle Bagger w/Lvrs Blk CRD	32	532 12 68-75	Rivet Rd Hd Drilled 3/8 Dia.
5	874 98 10-24	Screw Pan Head #10-24 x 1.50 Blk	33	532 16 93-80	Plug Mulch 107 CRD
6	874 98 10-32	Screw Pan Hd	34	532 16 55-70	Handle Mulch
7	873 40 10-00	Nut Wiz Lock Hex Serr/Hd 10-24	35	532 16 55-72	Pin Mulcher
8	532 19 24-70	Cover Bagger	36	819 13 20-12	Washer 13/32 x 1-1/4 x 12 Ga.
9	872 14 04-18	Bolt Carriage 1/4-20 x 2.25d x Gr. 5	37	532 17 54-01	Plug Support Bagger CRD
10	532 18 12-82	Tube Support Bagger CRD	38	872 01 05-20	Bolt 5/16-18 x 2-1/2
11	532 16 57-19	Bracket Support Upper Bag CRD	39	532 18 09-85	Seal
12	532 18 88-48	Bracket Pivot LH	41	532 16 96-83	Bracket Pnt Adj Pvt Bagger CRD
13	874 76 06-12	Bolt Fin Hex 3/8-16 unc x 3/4	43	532 17 40-83	Plug Tubing End
14	874 52 06-36	Bolt Fin Hex 3/8-16 x 2-1/4 Gr. 5	46	872 11 05-10	Bolt Carr 5/16-18 x 1-1/4 Gr. 5
15	532 12 46-70	Retainer Spring	47	532 19 37-04	Tube Upper Bagger
16	873 90 06-00	Nut Lock Flg 3/8-16 unc	49	532 19 33-05	Bar Spreader Bagger
17	872 14 05-06	Bolt Rdhd Sht Sqnk 5/16 -18 unc x 3/4	50	873 80 05-00	Nut Lock Hx w/Ins 5/16-18 unc
19	873 90 05-00	Nut Lock Hex Flange 5/16-18	51	532 19 99-03	Latch Spring Bagger
20	532 18 88-47	Bracket Pivot RH	52	872 14 04-06	Bolt Rdhd Sqnk 1/4-20 x 3/4 Gr. 5
21	532 40 61-80	Bag Asm CRD	53	873 51 04-00	Nut Keps Hex 1/4-20 unc
22	532 16 57-81	Bracket Side Bagger CRD			
24	532 16 57-83	Tube Pivot Bagger CRD			
25	532 19 37-05	Tube Front Bagger			

NOTE: All component dimensions given in U.S. inches
1 inch = 25.4 mm

**TRACTOR - MODEL NO. MB20107HBRK (96061020901), PRODUCT NO. 960 61 02-09
MOWER LIFT**

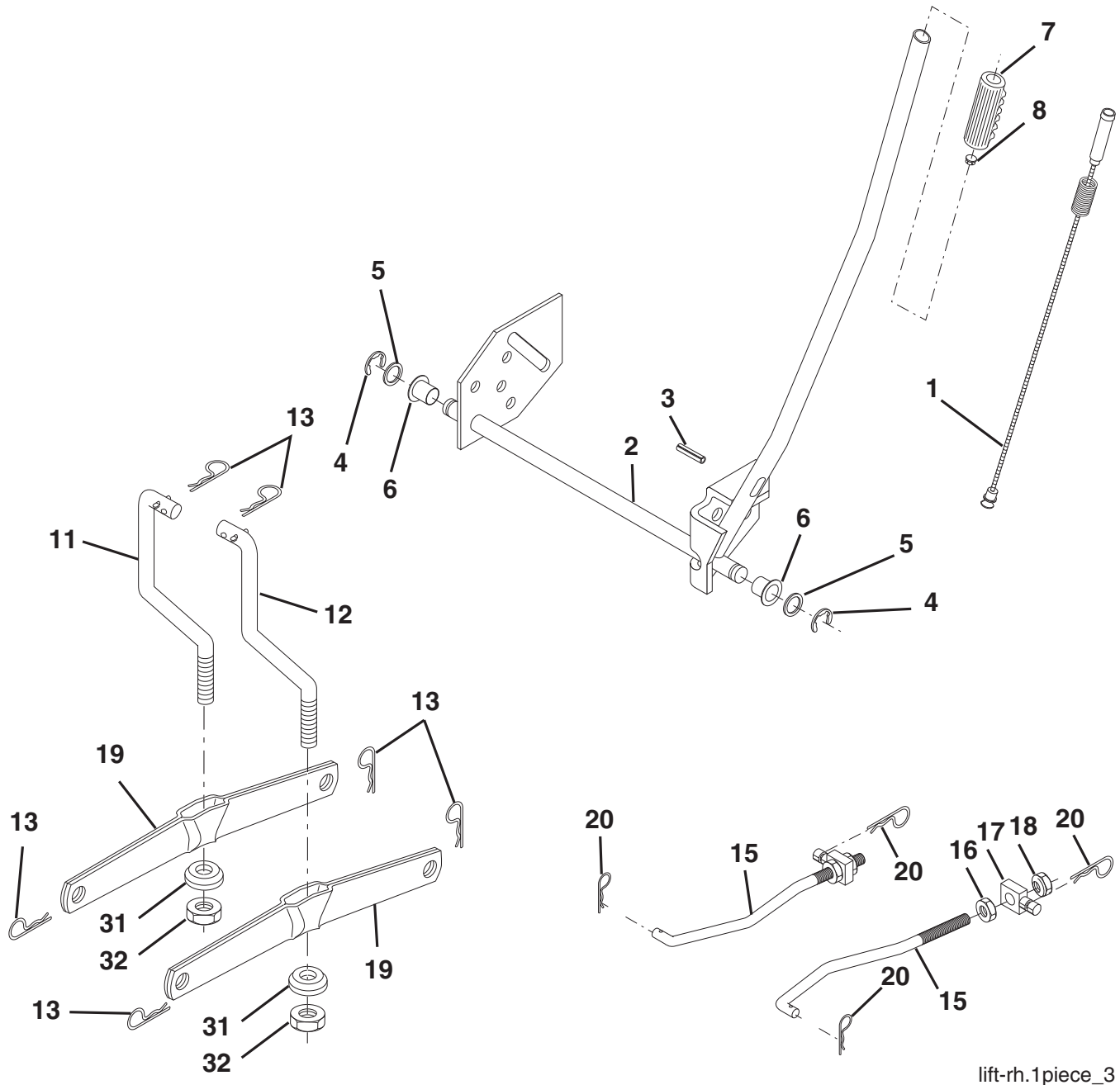

lift-rh.1piece_3

KEY NO.	PART NO.	DESCRIPTION
1	532 19 84-17	Washer Asm Inner Spring w/Plunger
2	532 19 80-70	Shaft Asm. Lift
3	532 18 88-22	Pin Groove
4	812 00 00-02	E Ring #5133-62
5	819 21 16-21	Washer 21/32 x 1 x 21 Ga.
6	532 12 01-83	Bearing Nylon
7	532 10 94-13	Grip Handle Bicycle
8	532 12 45-26	Button Plunger Black
11	532 16 58-29	Link Asm Lift L.H.
12	532 16 58-31	Link Asm Lift R.H.
13	532 12 46-70	Retainer Spring

KEY NO.	PART NO.	DESCRIPTION
15	532 17 32-88	Link Front
16	873 35 08-00	Nut Jam Hex 1/2-13 unc
17	532 17 56-89	Trunnion Blk Zinc
18	873 80 08-00	Nut Lock w/wsh 1/2-13 unc
19	532 13 98-68	Arm Suspension Mower
20	532 19 42-09	Retainer Spring
31	532 16 98-65	Bearing, Pvt. Lift.
32	873 54 06-00	Nut Crownlock 3/8-24

NOTE: All component dimensions given in U.S. inches
1 inch = 25.4 mm

