

**REPAIR PARTS MANUAL**  
**MODEL NO. MBA14597BR2 (96061029300)**  
**Lawn Tractor**

---

**Mr. Bricolage**

# HOW TO USE THIS MANUAL

This manual is designed to provide the customer with a means to identify the parts on his/her tractor when ordering repair parts. The illustrations may or may not represent the actual assemblies; therefore, it is not recommended to use this manual as a guide to assemble or disassemble the tractor. Some hardware and parts are drawn larger in order to more readily identify them.

Each tractor has its own model number.

The model number for your tractor can be found on the fender under the seat.

When ordering parts, always give the following information:

- Product - "Tractor"
- MODEL NUMBER - "MBA14597BR2 (96061029300)"
- Part Number
- Part Description

## TABLE OF CONTENTS

SCHEMATIC .....	3
ELECTRICAL.....	4-5
CHASSIS .....	6-7
DRIVE.....	8-9
ENGINE.....	10-11
STEERING .....	12-13
MOWER DECK .....	14-15
MOWER LIFT.....	16
SEAT .....	17
DECALS.....	18
BAGGER.....	19

# TRACTOR - MODEL NO. MBA14597BR2 (96061029300), PRODUCT NO. 960 61 02-93 SCHEMATIC

SCH08

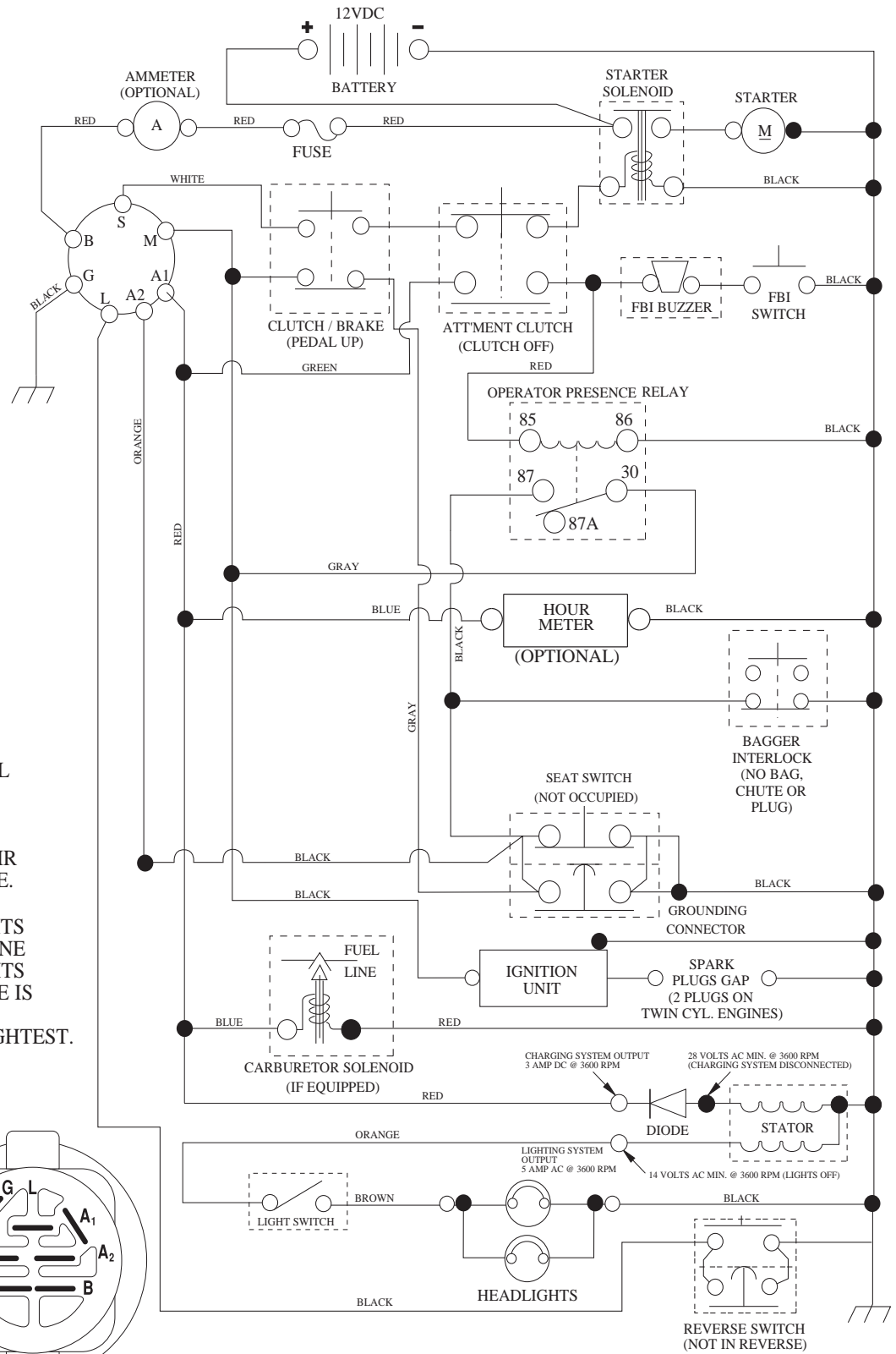

**NOTE**

YOUR TRACTOR IS EQUIPPED WITH A SPECIAL ALTERNATOR SYSTEM. THE LIGHTS ARE NOT CONNECTED TO THE BATTERY, BUT HAVE THEIR OWN ELECTRICAL SOURCE. BECAUSE OF THIS, THE BRIGHTNESS OF THE LIGHTS WILL CHANGE WITH ENGINE SPEED. AT IDLE THE LIGHTS WILL DIM. AS THE ENGINE IS SPEEDED UP, THE LIGHTS WILL BECOME THEIR BRIGHTEST.

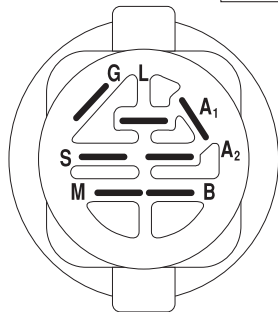

**IGNITION SWITCH**

POSITION	CIRCUIT	"MAKE"
OFF	M+G+A1	
RUN/OVERRIDE	B+A1	
RUN	B+A1	L+A2
START	B + S + A1	

**WIRING INSULATED CLIPS**

NOTE: IF WIRING INSULATED CLIPS WERE REMOVED FOR SERVICING OF UNIT, THEY SHOULD BE RE-INSTALLED TO PROPERLY SECURE YOUR WIRING.

○  
REMOVABLE CONNECTIONS

●  
NON-REMOVABLE CONNECTIONS

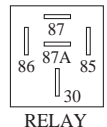

RELAY

**TRACTOR - MODEL NO. MBA14597BR2 (96061029300), PRODUCT NO. 960 61 02-93  
ELECTRICAL**

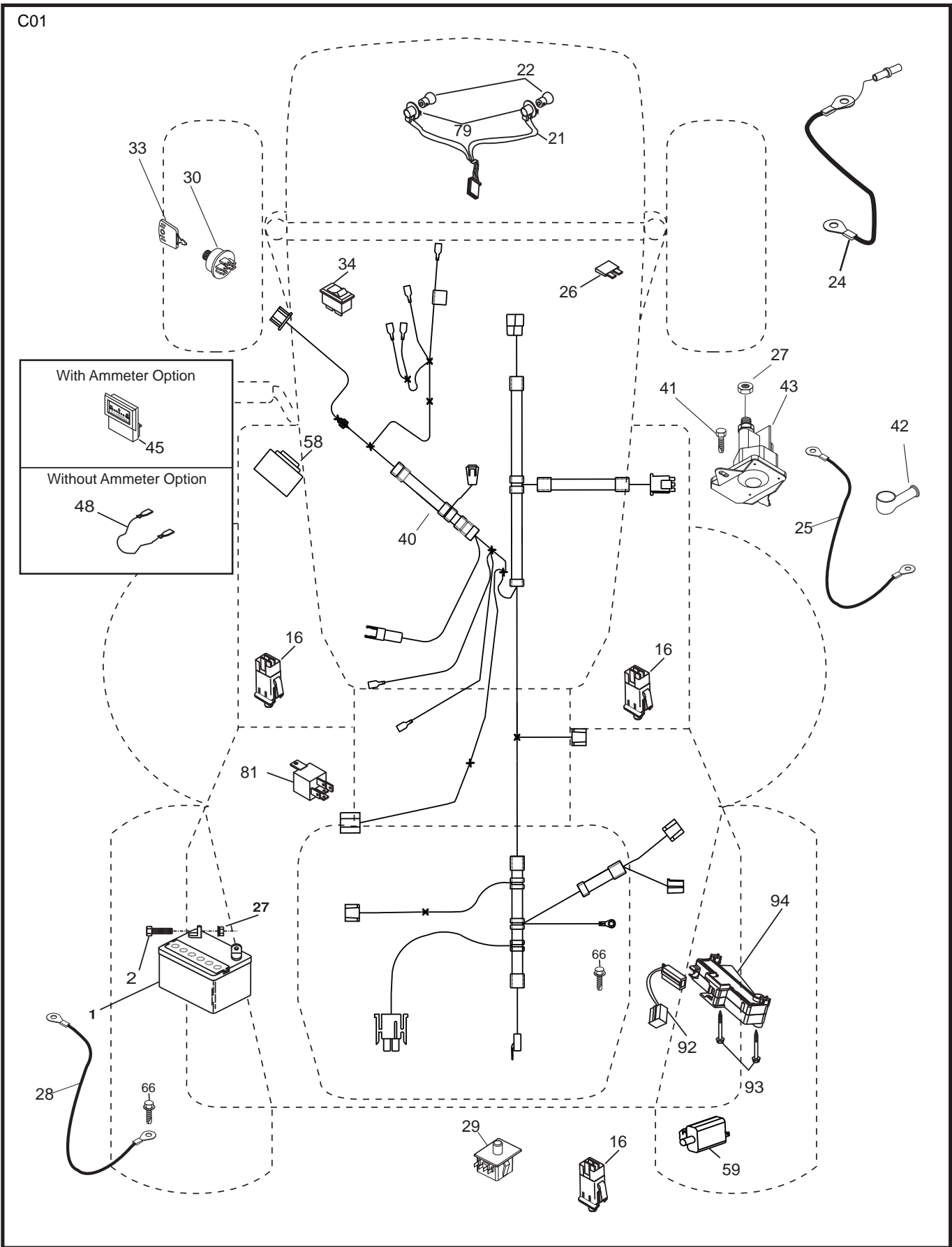

**TRACTOR - MODEL NO. MBA14597BR2 (96061029300), PRODUCT NO. 960 61 02-93  
ELECTRICAL**

<b>KEY NO.</b>	<b>PART NO.</b>	<b>DESCRIPTION</b>
1	532 16 34-65	Battery
2	874 76 04-12	Bolt Hex Hd 1/4-20 unc x 3/4
16	532 17 61-38	Switch Interlock Push-In
21	532 18 37-59	Harness Asm. Light
22	532 00 41-52	Bulb
24	532 42 12-99	Cable Starter 6 Ga. 11" Red
25	532 16 59-87	Cable Battery CRD 56" Red
26	532 17 51-58	Fuse 20 Amp
27	873 51 04-00	Nut Keps Hex 1/4-20 unc
28	532 12 77-25	Cable Ground 6 Ga. 18" Black
29	532 19 27-49	Switch Seat
30	532 19 33-50	Switch Ignition
33	532 41 19-35	Key/Chain
34	532 11 07-12	Switch Light/Reset B/B/Red
40	532 19 74-36	Harness Ignition
41	871 11 04-08	Bolt Flk Fin Hex 1/4-20 unc x 1/2
42	532 13 15-63	Cover Terminal Red
43	532 19 25-07	Solenoid
48	532 14 08-44	Adapter Ammeter Rectangular
58	532 16 94-19	Buzzer CRD
59	532 18 03-79	Switch FBI CRD
66	817 49 06-08	Screw Thdrol 3/8-16 x 1/2 Ty-Tt
79	532 17 52-42	Socket Asm Bulb
81	532 10 97-48	Relay Asm
92	532 19 66-15	Harness Pigtail Console ROS
93	532 19 25-40	Screw Plastite 10-14 x 2.0
94	532 19 18-34	Module Reverse ROS

**NOTE:** All component dimensions given in U.S. inches.  
1 inch = 25.4 mm.



**TRACTOR - MODEL NO. MBA14597BR2 (96061029300), PRODUCT NO. 960 61 02-93  
CHASSIS AND ENCLOSURES**

<b>KEY NO.</b>	<b>PART NO.</b>	<b>DESCRIPTION</b>	<b>KEY NO.</b>	<b>PART NO.</b>	<b>DESCRIPTION</b>
1	532 17 46-20	Chassis	171	872 14 06-20	Bolt Rdhd Sqnk 3/8-16 x 2-1/2 Gr. 5
2	532 18 03-84	Drawbar	172	819 13 20-16	Washer 13/32 x 1-1/4 x 16 Ga.
3	817 06 06-12	Screw 3/8-16 x .75	173	873 51 06-00	Nut, Keps Hex 3/8-16 unc
5	532 15 52-72	Bumper Hood/Dash	175	532 18 82-03	Trap Door CRD
6	532 18 44-19	Saddle	179	532 18 82-02	Rod Pivot FBI CRD
8	532 12 64-71	Clip Insulator 13/32 Mtg. Hole	184	532 17 46-62	Bracket Actuator Bagger CRD
9	532 19 46-88	Dash	185	532 18 11-01	Knob Rod
10	872 14 06-08	Bolt, Carriage 3/8-16 x 3/4	186	532 16 07-93	Latch Asm Multch Bagger
11	532 17 49-96	Panel, Dash, LH	187	532 12 50-04	Nut Weld .327/.304 #10-24
13	532 18 17-19	Panel, Asm. Dash RH	188	819 06 12-16	Washer #10
15	874 18 05-12	Screw, Machine, Truss Head 5/16-18 unc x 3/4	189	810 07 10-00	Washer Lock #10
16	873 51 05-00	Nut	190	871 08 10-10	Screw Pan Hd Phillips 10-24 x 5/8
17	532 42 45-65	Hood Assembly	198	532 16 89-37	Nut Push
18	532 18 49-21	Bumper Hood	205	817 49 06-08	Screw 3/8-16 x 1/2
24	874 78 06-16	Bolt	207	817 67 05-08	Screw 5/16-18 x 1/2
25	819 13 13-12	Washer 13/32 x 13/16 x 12 Ga.	208	817 67 06-08	Screw Thdrol 3/8-16 x 1/2
26	873 80 06-00	Nut	209	817 00 06-12	Screw Hex Wsh Thdrol 3/8-16 x 3/4
28	532 43 30-01	Grille	256	532 18 13-61	Cover Fender Rack CRD
30	532 40 35-18	Fender	258	532 42 45-59	Lens RH Laser III
31	532 16 51-56	Bracket, Fender Support	259	532 42 45-60	Lens LH Laser III
33	532 40 34-11	Footrest, LH	260	532 42 45-61	Cover Lens Laser III
34	532 40 34-10	Footrest, RH	263	532 18 42-66	Bezel Grille RH
35	872 11 06-06	Bolt	264	532 18 42-65	Bezel Grille LH
37	817 49 05-08	Screw Thdrol 5/16-18 x 1/2 TYT	265	532 18 57-04	Seal RH Side Bagger
38	532 18 17-48	Bracket Asm Pivot Mower Rear	266	532 18 57-03	Seal LH Side Bagger
39	532 40 78-07	Bracket Pivot	274	532 42 45-55	Insert Grille LH
69	532 14 24-32	Screw Hex 1/4-1/2	275	532 42 45-57	Insert Grille RH
89	532 19 73-39	Console	278	532 41 63-58	Screw #10 x .0750 BOS Thread
141	873 90 06-00	Nut	307	532 42 09-19	Shield Chassis Front
145	532 40 91-67	Rod Pivot/Hood	--	532 00 54-79	Plug, Button
162	532 18 03-82	Bracket Exten Chassis LH CRD			
163	532 18 03-83	Bracket Exten Chassis RH CRD			
164	532 16 56-05	Support Battery CRD			
165	532 18 13-56	Cover Battery CRD Lt			
170	532 19 94-88	Backplate CRD			

**NOTE:** All component dimensions given in U.S. inches.  
1 inch = 25.4 mm.

TRACTOR - MODEL NO. MBA14597BR2 (96061029300), PRODUCT NO. 960 61 02-93  
DRIVE

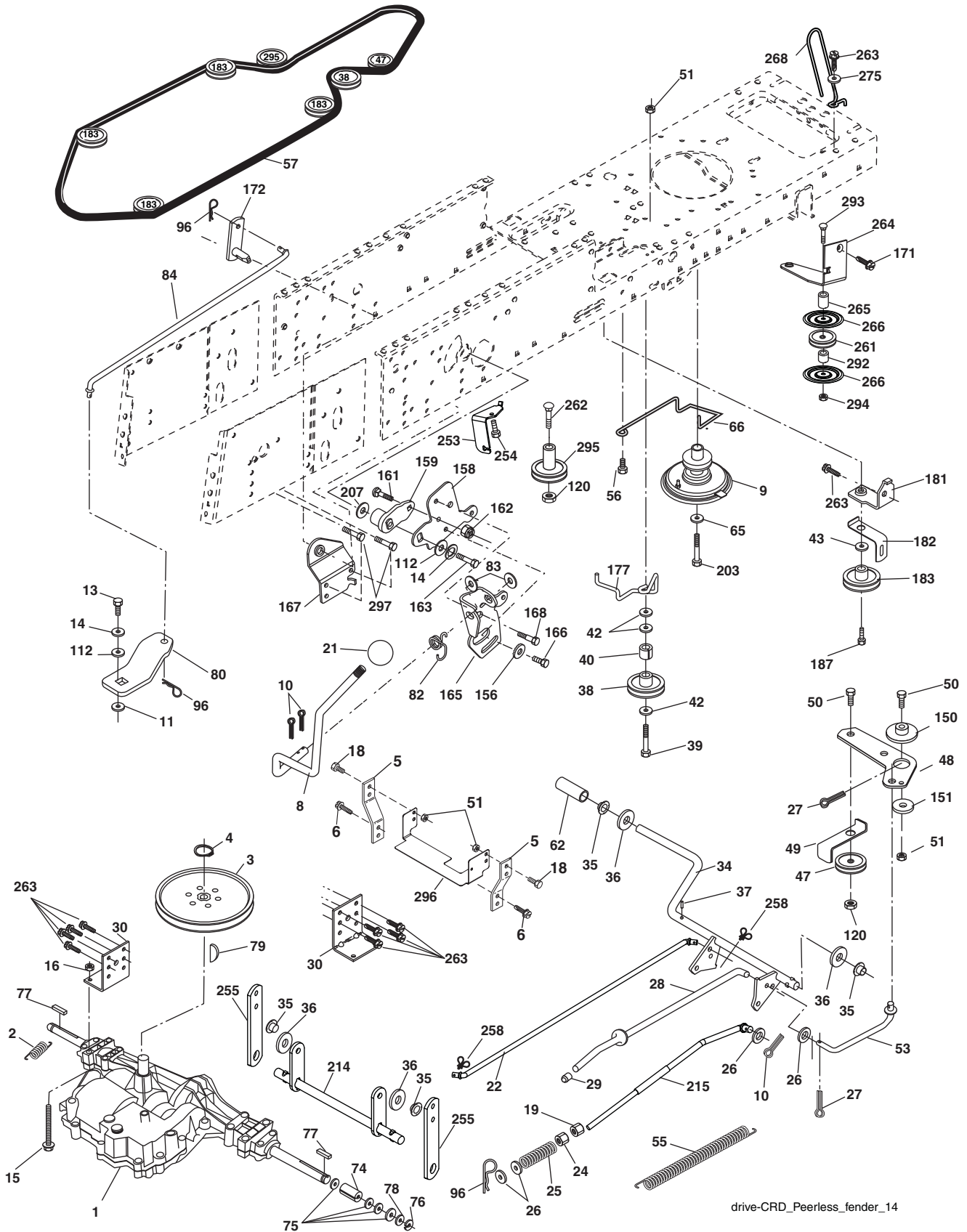

drive-CRD\_Peerless\_fender\_14



# TRACTOR - MODEL NO. MBA14597BR2 (96061029300), PRODUCT NO. 960 61 02-93 DRIVE

KEY NO.	PART NO.	DESCRIPTION	KEY NO.	PART NO.	DESCRIPTION
1	-----	Transaxle Peerless 206-546	82	532 16 57-11	Spring, Torsion
2	532 14 66-82	Spring Brake Return	83	819 17 12-16	Washer 17/32 x 3/4 x 16 Ga.
3	532 16 59-99	Pulley Transaxle	84	532 16 56-21	Link Shift
4	812 00 00-28	Ring Retainer #5100-62	96	532 12 47-88	Spring, Retainer 1"
5	532 12 15-20	Strap Torque 30 Degrees	112	819 09 12-10	Washer 9/32 x 3/4 x 10 Ga.
6	817 06 05-12	Screw 5/16-18 x 3/4	120	873 90 06-00	Nut Lock 3/8-16
8	532 19 27-06	Rod Shift Fender Adjust Lt	150	532 16 58-50	Bushing, Bellcrank Grnd Dr
9	532 40 85-79	Clutch Asm Noram	151	819 13 32-10	Washer 13/32 x 2 x 10 Ga.
10	876 02 04-16	Pin, Cotter 1/8 x 1	156	532 16 60-02	Washer Srrd 5/16 ID x 1.125
11	532 10 57-01	Washer Plate Shf .3888 Sq Hole	158	532 16 55-89	Bracket Shift Mount
13	874 55 04-12	Bolt 1/4-28 unf Gr. 8 w/Patch	159	532 18 39-00	Hub Tapered Flange Shift Lt
14	810 04 04-00	Washer, Lock Hvy Helical	161	872 14 04-06	Bolt Rdhd Sqnk 1/4-20 x 3/4 Gr. 5
15	874 49 05-44	Bolt Hex FGHD 5/16-18 x Gr. 5	162	873 68 04-00	Nut Crownlock 1/4-20 unc
16	873 80 05-00	Nut, Lock Hex w/lns 5/16-18 unc	163	874 78 04-16	Bolt Hex Fin 1/4-20 unc x 1 Gr. 5
18	874 78 06-16	Bolt Hex 3/8-16 unc x 1 Gr. 5	165	532 16 56-23	Bracket Pivot Lever
19	873 80 06-00	Nut, Lock Hex w/Wsh 3/8-16 unc	166	817 49 05-10	Screw 5/16-18 x 5/8
21	532 10 69-33	Knob Round 1/2-13 unc Blk	167	532 16 55-88	Bracket Support Shift CRD
22	532 17 56-07	Rod, Brake CRD Main	168	532 16 54-92	Bolt Shoulder 5/16-18 x .561
24	873 35 06-00	Nut	171	817 49 06-08	Screw Thdrol 3/8-16 x 1/2 Ty-Tt
25	532 10 68-88	Spring, Rod, Brake	172	532 16 56-35	Shaft Asm Shift Front CRD PMST
26	819 13 13-16	Washer 13/32 x 13/16 x 16 Ga.	177	532 16 59-32	Keeper Flat Idler 3.06" CRD
27	876 02 04-12	Pin, Cotter 1/8 x 3/4	181	532 18 02-11	Bracket Idler Ground Drive CRD
28	532 17 57-65	Rod, Parking Brake	182	532 18 26-82	Keeper Belt 2.5" Od V-Idler CRD
29	532 07 16-73	Cap, Parking Brake	183	532 19 95-34	Pulley V-Idler GRND DR. CRD
30	532 17 49-73	Bracket, Mfg. Transaxle	187	817 58 05-20	Screw 5/16-18 x 1.25
34	532 17 55-78	Shaft, Asm Pedal Foot CRD	203	871 17 07-80	Bolt Hex 7/16-20 x 5
35	532 12 01-83	Bearing, Nylon	207	532 16 98-45	Washer Nylon
36	819 21 16-16	Washer 21/32 x 1 x 16 Ga.	214	532 17 56-09	Shaft Asm. Brake
37	532 12 49-63	Pin, Roll 3/16 x 1"	215	532 41 01-42	Rod Brake Secondary
38	532 16 59-36	Pulley, Flat	253	532 17 50-28	Bracket Cable Chassis
39	874 76 06-44	Bolt Fin Hex 3/8-16 unc x 2-3/4	254	817 00 06-16	Screw 3/8-16 x 1
40	532 12 49-65	Spacer, Split 395 x 59 Bzp	255	532 17 56-08	Brace Shaft Brake
42	819 13 13-12	Washer 13/32 x 13/16 x 12 Ga.	258	532 17 80-62	Clip Retainer
43	819 11 10-12	Washer 11/32 x 5/8 x 12 Ga.	261	532 13 14-94	Pulley Idler Flat Plated
47	532 12 77-83	Pulley, Idler, V Groove Plastic	262	872 11 06-22	Bolt Rdhd 3/8-16 unc x 2-3/4 Gr. 5
48	532 15 44-07	Bellcrank Clutch Grnd Drv	263	817 00 06-12	Screw Hex Wsh THDR 3/8-16 x 3/4
49	532 12 32-05	Retainer, Belt Style Spring	264	532 43 11-74	Bracket Idler Chassis
50	872 11 06-12	Bolt Carr Sh 3/8-16 x 1-1/2 Gr. 5	265	532 40 02-71	Spacer Noram CRD
51	873 68 06-00	Nut, Crownlock 3/8-16 unc	266	532 18 20-61	Shield Idler
53	532 19 96-52	Link, Clutch 7.66	268	532 18 24-02	Guard Muffler OHV B&S RH
55	532 10 57-09	Spring, Return, Clutch	275	819 13 16-14	Washer 13/32 x 1 x 14 Ga.
56	817 06 06-20	Screw 3/8-16 x 1-1/4	292	532 40 46-07	Spacer Noram
57	532 16 56-31	V-Belt Drive	293	872 14 06-28	Bolt 3/8-16 x 3 1/2
62	532 12 48-72	Cover, Pedal	294	532 19 70-33	Nut Jam 3/8-16
65	810 04 07-00	Washer	295	532 17 91-14	Pulley Idler Composite
66	532 15 47-78	Keeper, Belt Engine F-Proof	296	532 42 09-20	Shield Chassis Rear
74	532 13 70-57	Spacer Axle	297	817 49 06-10	Screw Hxwsh 3/8-16 x 5/8
75	532 12 17-49	Washer 25/32 x 1-1/4 x 16 Ga.			
76	812 00 00-01	Ring, E			
77	532 12 35-83	Key, Square			
78	532 12 17-48	Washer 25/32 x 1-5/8 x 16 Ga.			
79	532 12 50-96	Key Woodruff			
80	532 14 50-90	Arm Shift PMST 20" Tires			

**NOTE:** All component dimensions given in U.S. inches  
1 inch = 25.4 mm

**TRACTOR - MODEL NO. MBA14597BR2 (96061029300), PRODUCT NO. 960 61 02-93  
ENGINE**

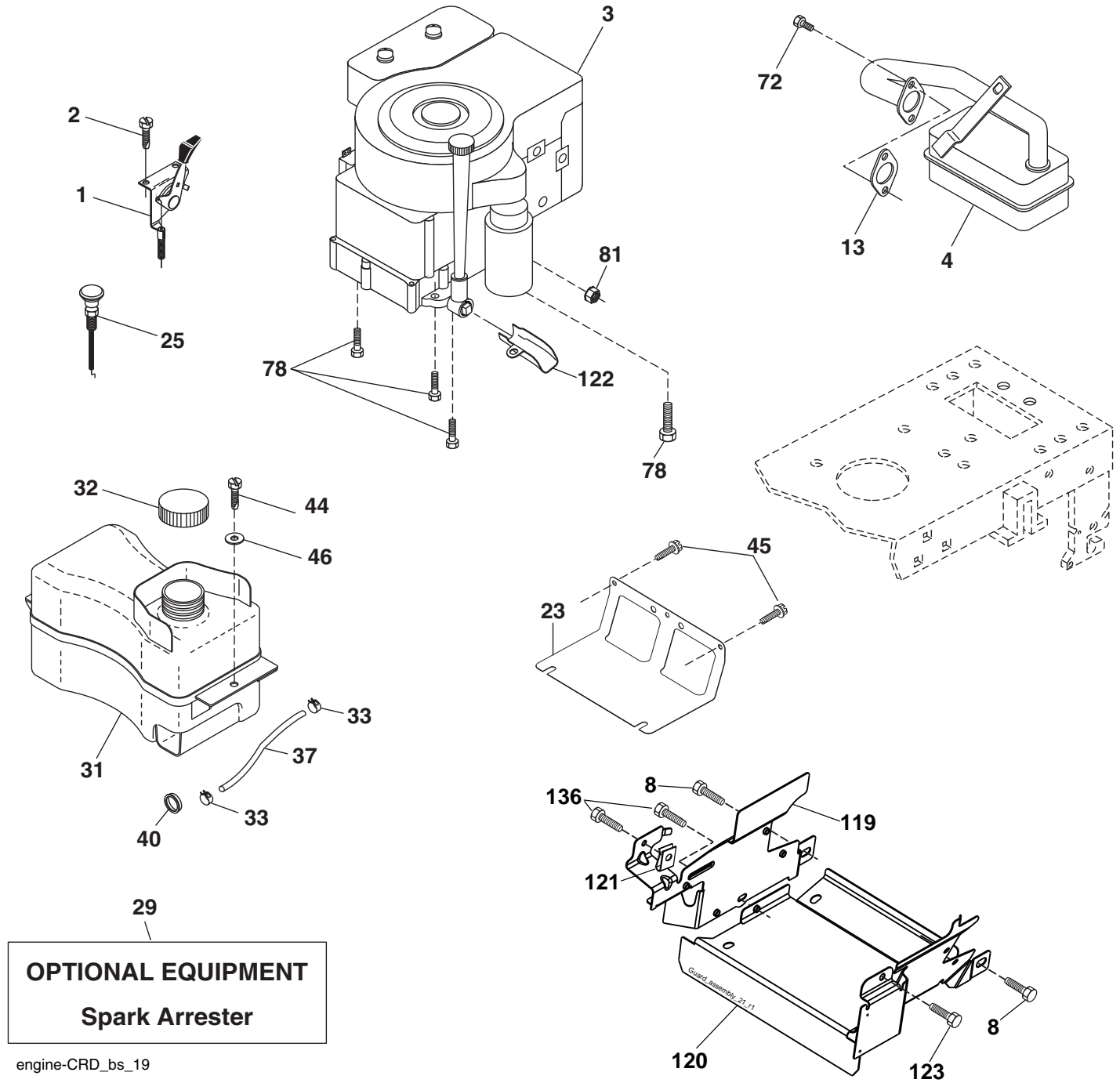

**TRACTOR - MODEL NO. MBA14597BR2 (96061029300), PRODUCT NO. 960 61 02-93  
ENGINE**

<b>KEY NO.</b>	<b>PART NO.</b>	<b>DESCRIPTION</b>
1	532 17 05-51	Control Throttle/Choke
2	817 72 04-08	Screw Hex Thd Cut 1/4-20 x 5/8 T
3	-----	Engine B&S Model 31A507-1391-B1
4	532 13 73-52	Muffler Exhaust
8	532 17 18-77	Bolt .5/16-18 unc x 3/4
13	532 16 52-91	Gasket
23	532 16 98-37	Shield Browning/Debris Guard
25	532 19 06-95	Control Choke
29	532 13 71-80	Arrester Spark
31	532 40 75-16	Tank Fuel
32	532 43 02-20	Cap Asm Fuel
33	532 12 34-87	Clamp Hose Blk
37	532 13 70-40	Line Fuel 20"
40	532 12 40-28	Bushing Snap
44	817 67 04-12	Screw Hexwsh Thdrol 3/8-16 x 3/4
45	817 00 06-12	Screw 3/8-16 x 3/4
46	819 09 14-16	Washer 9/32 x 7/8 x 16 Ga.
72	532 19 23-34	Screw Socket Hd 5/16-18 x .75
78	817 06 06-20	Screw 3/8-16 x 1-1/4
81	873 51 04-00	Nut Keps Hex 1/4-20 unc
119	532 19 97-68	Guard Asm Engine LH CRD
120	532 19 97-67	Guard Asm Engine RH CRD
121	532 19 66-88	Clips Threaded
122	532 42 19-22	Extension Drain Oil
123	817 67 05-08	Screw THDROL 5/16-18 X 1/2
136	532 13 77-29	Screw THDROL 1/4 - 20 X 5/8

**NOTE:** All component dimensions given in U.S. inches  
1 inch = 25.4 mm

**Engine Power Rating Information**

The gross power rating for individual gas engine models is labeled in accordance with SAE (Society of Automotive Engineers) code J1940 (Small Engine Power & Torque Rating Procedure), and rating performance has been obtained and corrected in accordance with SAE J1995 (Revision 2002-05). Torque values are derived at 3060 RPM; horsepower values are derived at 3600 RPM. Actual gross engine power will be lower and is affected by, among other things, ambient operating conditions and engine-to-engine variability. Given both the wide array of products on which engines are placed and the variety of environmental issues applicable to operating the equipment, the gas engine will not develop the rated gross power when used in a given piece of power equipment (actual "on-site" or net power). This difference is due to a variety of factors including, but not limited to, accessories (air cleaner, exhaust, charging, cooling, carburetor, fuel pump, etc.), application limitations, ambient operating conditions (temperature, humidity, altitude), and engine-to-engine variability. Due to manufacturing and capacity limitations, Briggs & Stratton may substitute an engine of higher rated power for this Series engine.

TRACTOR - MODEL NO. MBA14597BR2 (96061029300), PRODUCT NO. 960 61 02-93  
STEERING ASSEMBLY

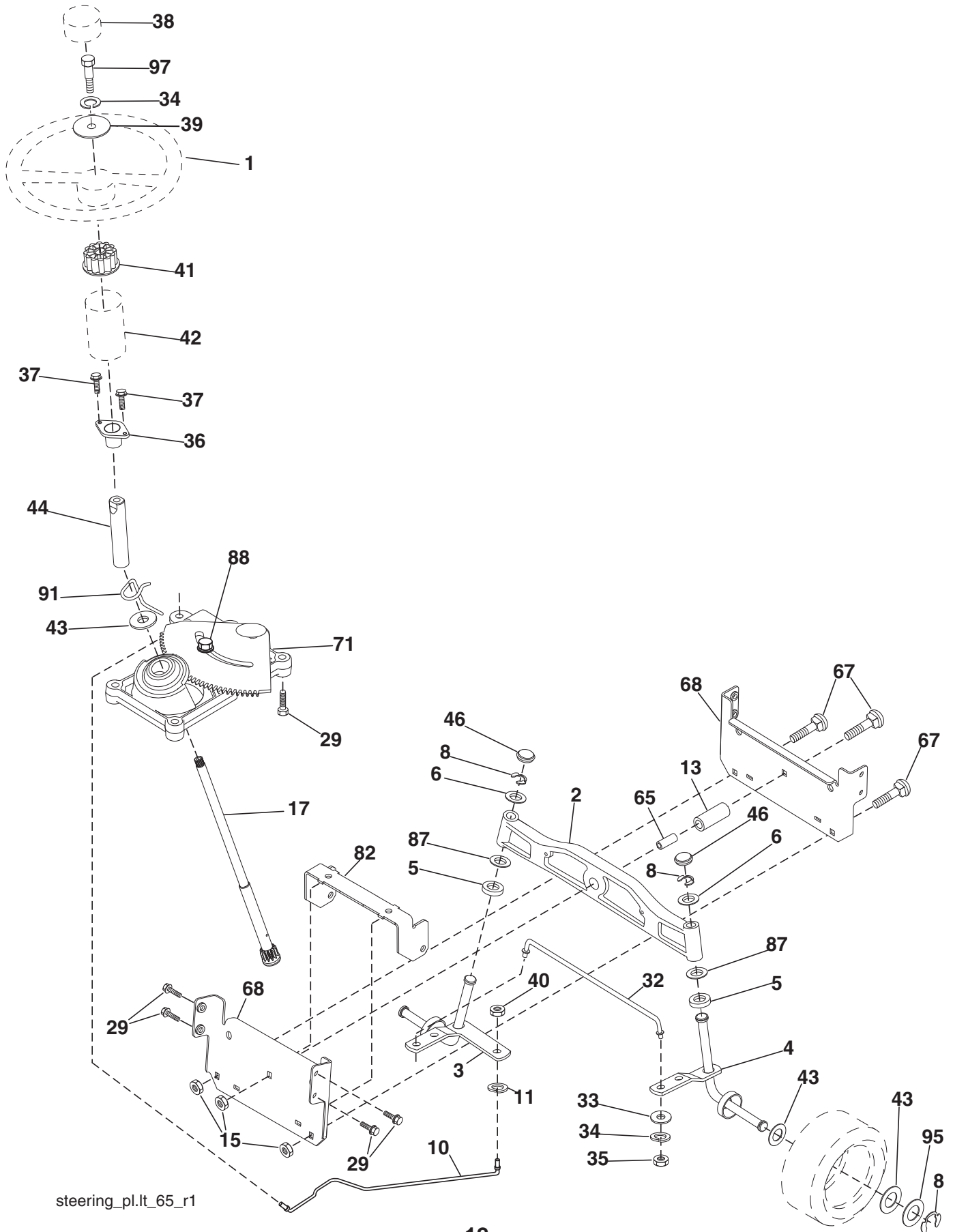

steering\_pl.lt\_65\_r1

**TRACTOR - MODEL NO. MBA14597BR2 (96061029300), PRODUCT NO. 960 61 02-93  
STEERING ASSEMBLY**

<b>KEY NO.</b>	<b>PART NO.</b>	<b>DESCRIPTION</b>
1	532 42 45-43	Steering Wheel
2	532 18 47-06	Cast Iron Axle Assembly
3	532 16 98-40	Spindle Assembly, LH
4	532 16 98-39	Spindle Assembly, RH
5	532 12 49-31	Bearing, Race, Thrust, Hardened
6	532 12 17-48	Washer 25/32 x 1-5/8 x 16 Ga.
8	812 00 00-29	Ring, Clip
10	532 17 51-21	Link, Drag
11	810 04 06-00	Washer, Lock
13	532 13 65-18	Spacer Brg Axle Front
15	873 90 06-00	Nut, Lock Flg 3/8-16
17	532 19 07-53	Shaft, Steering
29	817 00 06-12	Screw, 3/8-16 x 3/4
32	532 17 01-62	Rod, Tie
33	819 11 12-16	Washer 11/32 x 3/4 x 16 Ga.
34	810 04 05-00	Washer Lock Hvy Hlcl Spr 5/16
35	873 54 05-00	Nut Crownlock 5/16-24 unf
36	532 15 50-99	Bushing, Steering
37	532 15 29-27	Screw TT #10-32 x 5 x 3/8 Flange
38	532 42 41-47	Cap Wheel Steering
39	819 11 38-12	Washer 11/32 x 2-3/8 x 12 Ga.
40	873 54 06-00	Nut Crownlock 3/8-24
41	532 18 67-37	Adaptor, Steering Wheel
42	532 16 96-33	Boot, Steering Dash P/L Mtl
43	532 12 17-49	Washer 25/32 x 1-1/4 x 16 Ga.
44	532 19 07-52	Extension Steering
46	532 12 12-32	Cap, Spindle
65	532 41 47-36	Spacer Brace Axle
67	872 11 06-18	Bolt Rdhd Sq 3/8-16 unc x 2-1/4
71	532 17 51-46	Steering Asm.
68	532 16 98-27	Brace Axle
82	532 19 99-78	Bracket Susp Chassis Front
87	532 17 39-66	Washer Flat .781 x 1-1/2 x .14
88	532 17 51-18	Bolt Shoulder 7/16-20 unc
91	532 17 55-53	Clip Steering
95	532 18 89-67	Washer Harden .793 x 1.637 x 060
97	532 42 89-82	Bolt Fin Hex 5/16-18 x 4 w/patch

**NOTE:** All component dimensions given in U.S. inches.  
1 inch = 25.4 mm.



**TRACTOR - MODEL NO. MBA14597BR2 (96061029300), PRODUCT NO. 960 61 02-93  
MOWER**

<b>KEY NO.</b>	<b>PART NO.</b>	<b>DESCRIPTION</b>	<b>KEY NO.</b>	<b>PART NO.</b>	<b>DESCRIPTION</b>
1	532 42 91-21	Housing Asm. Mower 97 CRD	68	532 42 95-32	Belt Drive 97 Mower
3	532 43 18-64	Bracket Asm. S-Bar Chass 97 CRD	69	532 16 54-82	Shaft Asm w/Lwr Brg RH Thd CRD
5	532 12 46-70	Retainer Spring	84	532 15 60-85	Keeper Belt Idler
6	532 16 55-57	Bar Sway 97 CRD	116	532 19 34-06	Bolt Shoulder
8	532 18 17-12	Bolt 3/8-24 x 1.25 Gr. 8 Patched	117	532 17 48-73	Wheel Gage
9	810 03 06-00	Washer Lock Hvy 3/8 Unplated	119	819 13 20-12	Washer 13/32 x 1-1/4 x 12 GA.
10	532 14 02-96	Washer Hard	124	872 11 06-12	Bolt Carr Sh 3/8-16 x 1-1/2 Gr. 5
11	532 42 79-84	Blade 3-1 LH 97 CRD	131	532 16 56-61	Chute Bagger CRD 97cm
13	532 13 76-45	Shaft Asm. w/Lower Bearing	152	532 17 60-74	Cable Clutch
14	532 12 87-74	Housing Mandrel Vented (Machd)	158	817 72 04-08	Screw Thd Cut 1/4-20 x 1/2
15	532 11 04-85	Bearing Ball Mandrel	185	532 18 82-34	Head Asm. Cable Clutch
16	532 42 79-85	Blade 3-1 RH 97 CRD Rear RH	260	817 67 06-08	Screw Thdrol 3/8-16 x 1/2
17	872 14 06-10	Bolt Carriage 3/8-16 x 1-1/4	298	817 49 06-28	Screw Thdrol 3/8-16 x 1-3/4
19	532 13 28-27	Bolt Shoulder 5/16-18 Thd Form	311	532 43 07-74	Cover Deck RH
20	532 18 17-13	Bolt 3/8-24 x 1.25 Gr. 8 Ptch Lhthd	312	532 43 07-75	Cover Deck LH
22	532 43 11-69	Bracket Idler Sprt 97 CRD Rear RH	--	532 18 18-57	Mandrel Assembly (Includes hous- ing, shaft assembly, and bear- ing only - pulley/nut/washer and blade bolt/washers not included)
27	532 42 79-81	Bracket Asm. Susp. Rear RH	--	532 18 18-58	Mandrel Asm CRDLH Threads SVC
30	532 17 39-84	Screw Thd Rolling	--	532 43 30-38	Replacement Mower, Com- plete (Std. Deck - Order sep- arately guage wheel compo- nents key nos. 116, 117 & 119)
31	532 18 76-90	Washer Spacer Mower Vented			
32	532 15 35-32	Mandrel Pulleys			
33	532 40 02-34	Nut Flg Top Lock			
36	532 14 67-63	Pulley Idler V-Groove Dim 4.25			
40	873 68 06-00	Nut Crownlock 3/8-16 unc			
41	873 90 06-00	Nut Lock Flg. 3/8-16 unc			
44	532 43 02-10	Cover Mandrel LH 97 CRD			
45	532 43 02-09	Cover Mandrel RH 97 CRD			
55	532 19 94-98	Arm Idler 97 CRD			
56	532 16 57-23	Spacer Retainer Mower			
61	532 19 94-86	Spring Tension Belt			
67	532 10 69-32	Knob Rd.			

**NOTE:** All component dimensions given in U.S. inches  
1 inch = 25.4 mm

**TRACTOR - MODEL NO. MBA14597BR2 (96061029300), PRODUCT NO. 960 61 02-93  
MOWER LIFT**

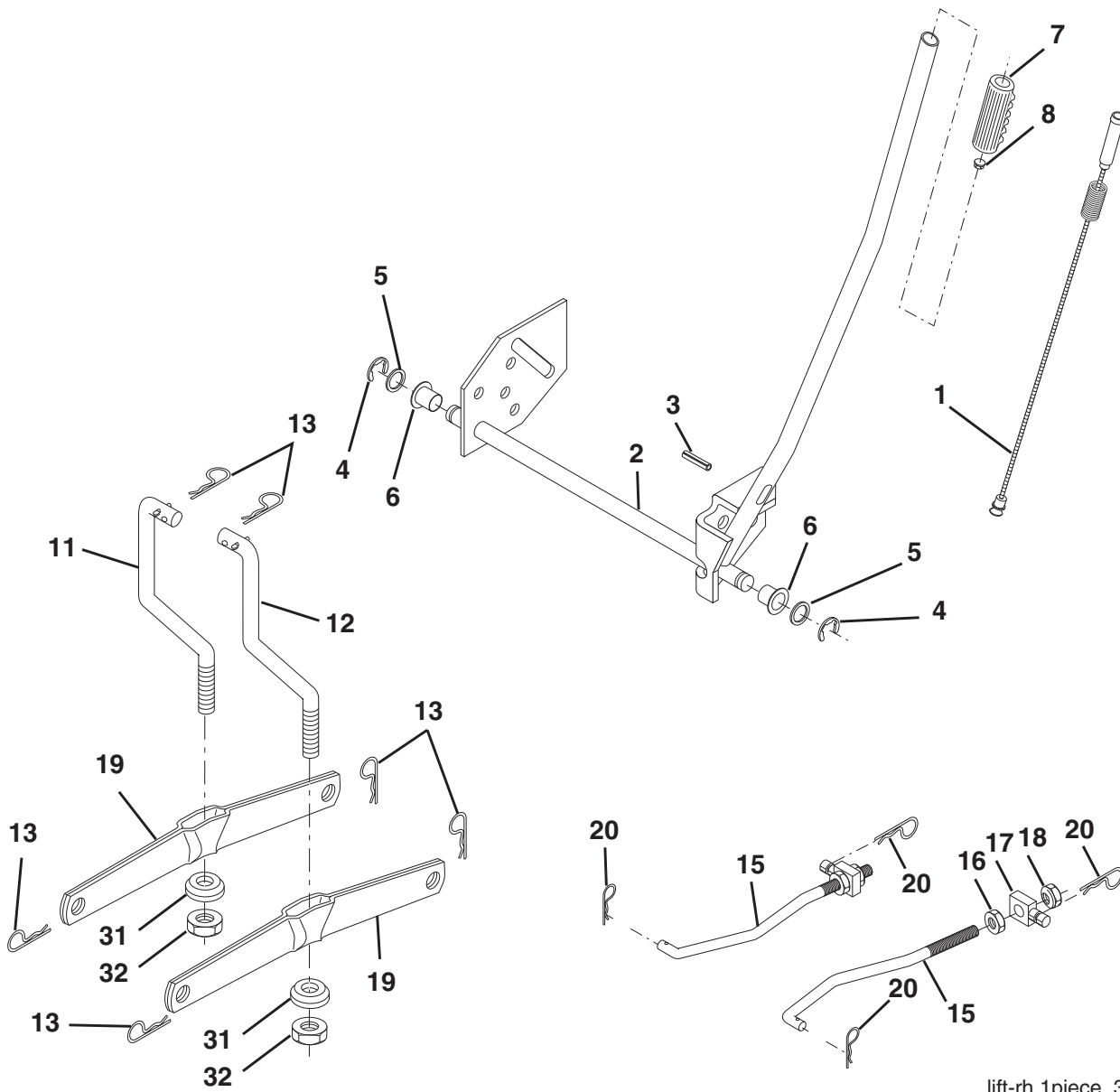

lift-rh.1piece\_3

KEY NO.	PART NO.	DESCRIPTION
1	532 40 49-81	Plunger Asm Lift Lever
2	532 15 94-71	Shaft Asm. Lift
3	532 10 57-67	Pin Groove
4	812 00 00-02	E Ring #5133-62
5	819 21 16-21	Washer 21/32 x 1 x 21 Ga.
6	532 12 01-83	Bearing Nylon
7	532 10 94-13	Grip Handle Bicycle
8	532 12 45-26	Button Plunger Black
11	532 13 98-65	Link Asm Lift LH
12	532 13 98-66	Link Asm Lift RH
13	532 12 46-70	Retainer Spring

KEY NO.	PART NO.	DESCRIPTION
15	532 17 32-88	Link Front
16	873 35 08-00	Nut Jam Hex 1/2-13 unc
17	532 17 56-89	Trunnion Blk Zinc
18	873 80 08-00	Nut Lock w/Wsh 1/2-13 unc
19	532 13 98-68	Arm Suspension Mower
20	532 19 42-09	Retainer Spring
31	532 16 98-65	Bearing, Pvt. Lift.
32	873 54 06-00	Nut Crownlock 3/8-24

**NOTE:** All component dimensions given in U.S. inches  
1 inch = 25.4 mm



**TRACTOR - MODEL NO. MBA14597BR2 (96061029300), PRODUCT NO. 960 61 02-93  
SEAT ASSEMBLY**

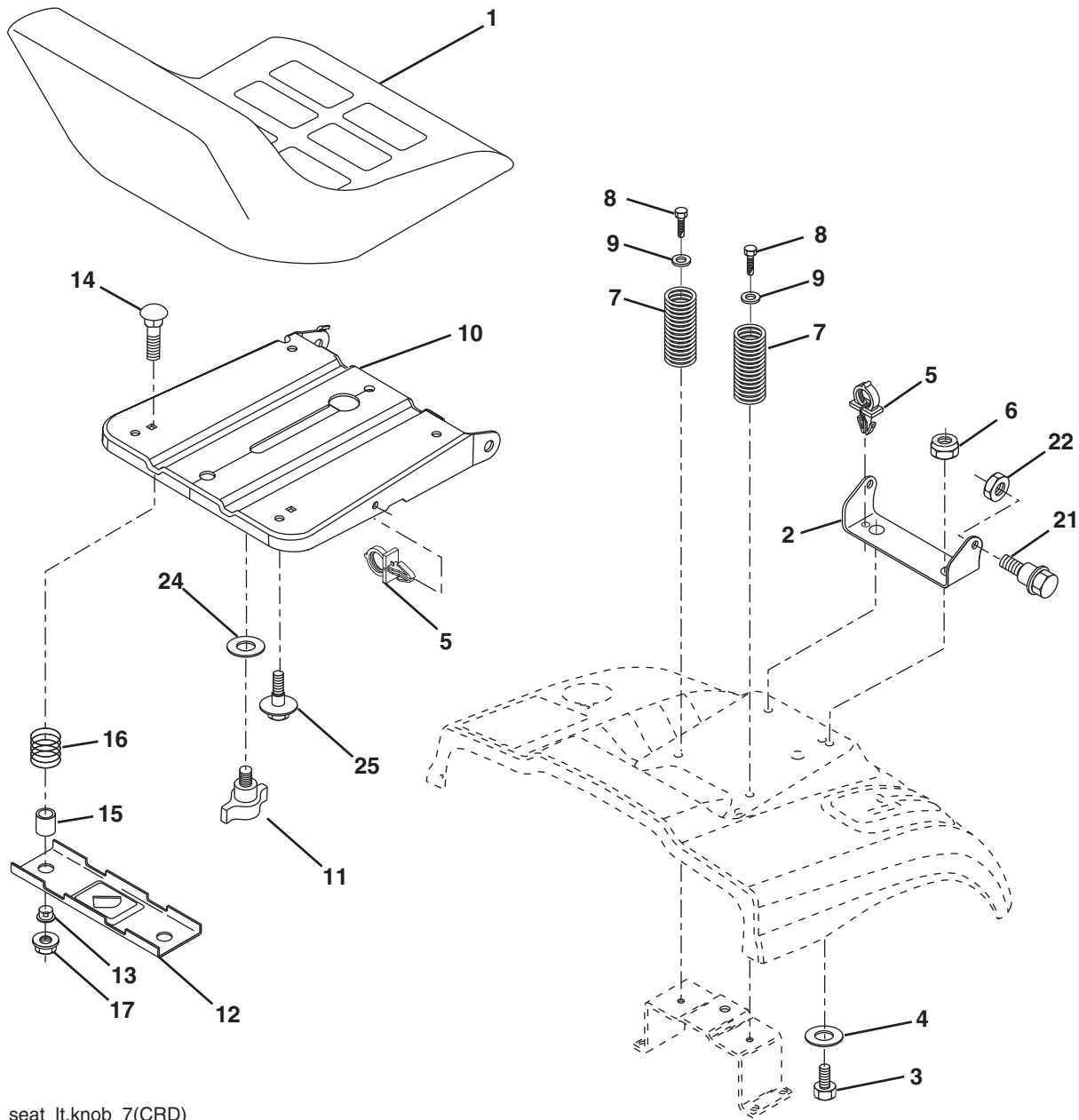

seat\_lt.knob\_7(CRD)

KEY NO.	PART NO.	DESCRIPTION
1	532 18 87-13	Seat
2	532 14 05-51	Bracket Pnt Pivot Seat (Blk)
3	871 11 06-16	Bolt Fin Hex 3/8-16 unc x 1
4	819 13 16-10	Washer Flat 13/32 x 1 x 10 Ga.
5	532 14 50-06	Clip Push In Hinged
6	873 80 06-00	Nut Lock Hex 3/8-16 unc
7	532 12 41-81	Spring Seat Cprsn 2 250 Blk Zi
8	817 00 06-16	Screw 3/8-16 x 1-1/2
9	819 13 16-14	Washer 13/32 x 1 x 14 Ga.
10	532 19 55-30	Pan Pnt Seat (Blk)
11	532 16 63-69	Knob Seat
12	532 17 46-48	Bracket Pnt Mounting Switch

KEY NO.	PART NO.	DESCRIPTION
13	532 12 12-48	Bushing Snap Blk Nyl 50 Id
14	872 05 04-12	Bolt Rdhd Sht Nk 1/4-20 x 1-1/2
15	532 13 43-00	Spacer Split
16	532 12 12-50	Spring Cprsn Plate SW 1.3 10 Ga.
17	532 12 39-76	Nut Lock 1/4 Lge Flg Gr. 5 Zinc
21	532 17 18-52	Bolt Shoulder 5/16-18 unc-2A
22	873 80 05-00	Nut Hex Lock w/Ins 5/16-18
24	819 17 19-12	Washer 17/32 x 1-3/16 x 12 Ga.
25	532 12 70-18	Bolt Shoulder 5/16-18 x 62

**NOTE:** All component dimensions given in U.S. inches.  
1 inch = 25.4 mm

**TRACTOR - MODEL NO. MBA14597BR2 (96061029300), PRODUCT NO. 960 61 02-93  
DECALS**

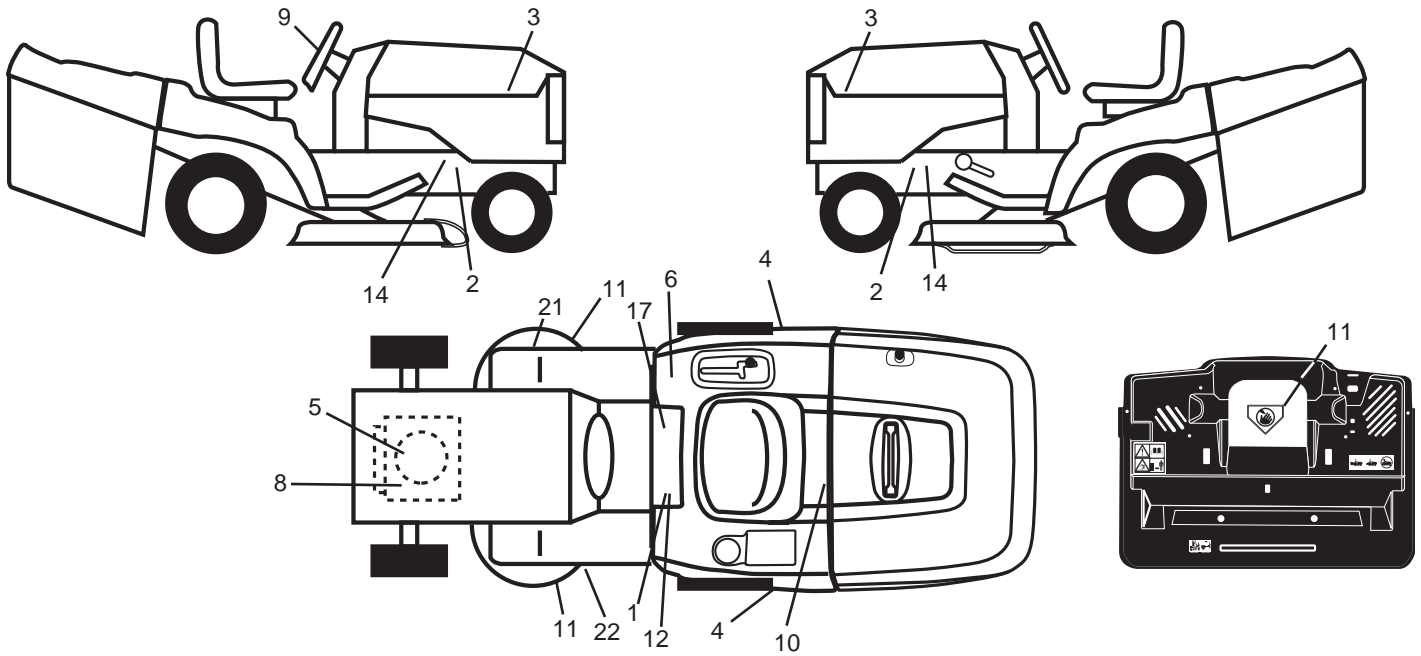

KEY NO.	PART NO.	DESCRIPTION
1	532 40 03-89	Decal Warning Syms. CE
2	532 40 11-46	Decal Warning Service/Fire
3	532 42 47-92	Decal Hood
4	532 43 37-26	Decal Fender
5	532 19 68-41	Decal Warning Eng. Symbols
6	532 18 04-32	Decal Fender 100 OB/CE
8	532 43 10-94	Decal Engine HP
9	532 42 43-14	Decal Strg Whl
10	532 14 50-05	Decal Bat Dan/Poi P/L Sym Wpn

KEY NO.	PART NO.	DESCRIPTION
11	532 18 21-66	Decal Mower Cut Finger Symbol
12	532 15 97-37	Decal Brake/Clutch Symbol Lt
14	532 15 97-36	Decal Chassis Hot Muffler
17	532 14 08-37	Decal Saddle Brake Parking
21	532 16 62-86	Decal Hex Belt Sch 92 CRD
22	532 18 78-11	Decal Deck Enviro
--	532 13 83-11	Decal Lift Handle
--	532 43 32-91	Manual Operator's (Euro)
--	532 43 32-92	Manual Parts

**WHEELS & TIRES**

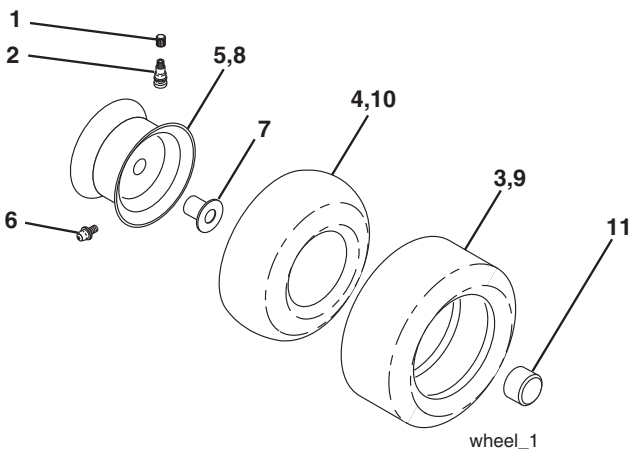

KEY NO.	PART NO.	DESCRIPTION
1	532 05 91-92	Cap Valve Tire
2	532 06 51-39	Stem Valve
3	532 10 62-22	Tire F Ts 15 x 6 0-6 Service
4	532 05 99-04	Tube Inner Front #35060
5	532 18 33-37	Rim Asm 6" Front Service
6	532 12 49-57	Fitting Grease
7	532 12 49-59	Bearing Flange
8	532 18 33-38	Rim Asm 8" Rear Service
9	532 12 46-35	Tire R Ts 18 x 8.5-8 C. Service
10	532 12 49-26	Tube Rear 9 5 x 8 Service
11	532 17 50-39	Cap Axle Blk 1 50 x 1 00
--	532 14 43-34	Sealant, Tire (10 oz. Tube)

**NOTE:** All component dimensions given in U.S. inches  
1 inch = 25.4 mm

# TRACTOR - MODEL NO. MBA14597BR2 (96061029300), PRODUCT NO. 960 61 02-93 BAGGER

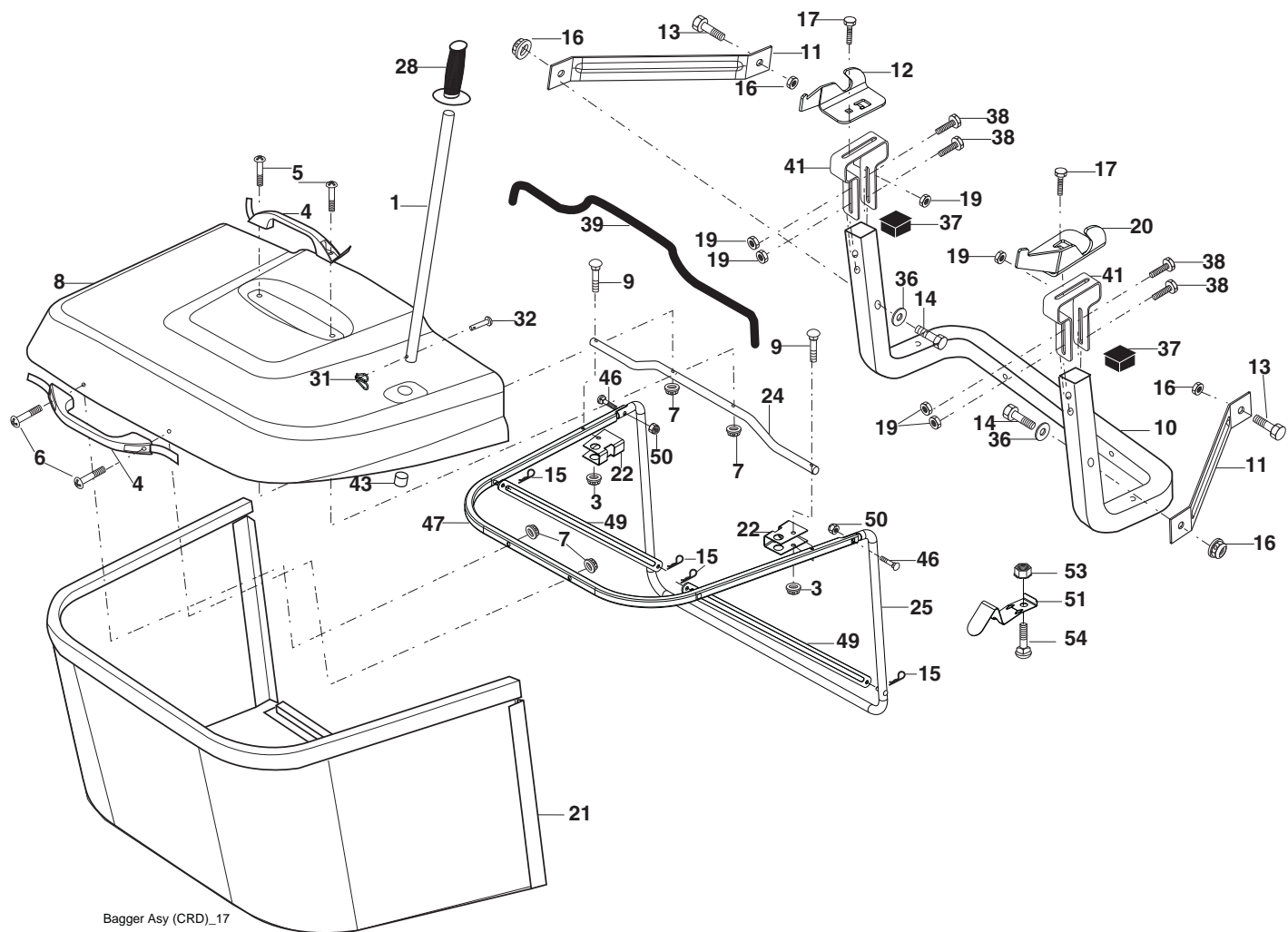

Bagger Asy (CRD)\_17

KEY NO.	PART NO.	DESCRIPTION	KEY NO.	PART NO.	DESCRIPTION
1	532 42 86-10	Tube Handle Bagger CRD	28	532 16 57-87	Grip Handle Black
3	532 12 39-76	Nut Lock 1/4 Lge Flg Gr. 5 Zinc	31	532 16 94-84	Retainer Clip
4	532 16 99-16	Handle Bagger w/Lvrs Gr. 5 Zinc	32	532 12 68-75	Rivet Rd Hd Drilled 3/8 Dia.
5	874 98 10-24	Screw Pan Head #10-24 x 1.50 Blk	36	819 13 20-12	Washer 13/32 x 1-1/4 x 12 Ga.
6	874 98 10-32	Screw Pan Hd	37	532 17 54-01	Plug Support Bagger CRD
7	873 40 10-00	Nut Wiz Lock Hex Serr/Hd #10-24	38	872 01 05-20	Bolt 5/16-18 x 2-1/2
8	532 40 35-26	Cover Bagger Steel	39	532 41 62-57	Seal Trim 37"
9	872 14 04-18	Bolt Carriage 1/4-20 x 2.25d x Gr. 5	41	532 43 27-55	Bracket Vert Adj Bagger CRD
10	532 18 12-82	Tube Support Bagger CRD	43	532 17 40-83	Plug Tubing End
11	532 16 57-19	Bracket Support Upper Bag CRD	46	872 11 05-10	Bolt Carr. 5/16-18 x 1-1/4 Gr. 5
12	532 18 88-48	Bracket Pivot LH	47	532 19 37-04	Tube Upper Bagger
13	874 76 06-12	Bolt 3/8-16 unc x 3/4	49	532 19 33-05	Spreader Bar Bagger
14	874 52 06-36	Bolt Fin Hex 3/8-16 x 2-1/4 Gr. 5	50	873 80 05-00	Nut Lock Hex w/Insert 5/16-18 unc
15	532 12 46-70	Retainer Spring	51	532 19 99-03	Latch Spring
16	873 90 06-00	Nut Latch Flg. 3/8-16 unc	53	873 51 04-00	Nut Keps Hex 1/4-20 unc
17	872 14 05-06	Bolt Rdhd Sht Sqnk 5/16-18 unc x 3/4	54	872 14 04-06	Bolt Rdhd Sqnk 1/4-20 x 3/4 Gr. 5
19	873 90 05-00	Nut Lock Hex Flange 5/16-18			
20	532 18 88-47	Bracket Pivot RH			
21	532 40 61-80	Bag Asm CRD			
22	532 42 82-36	Bracket Side Bagger CRD			
24	532 16 57-83	Tube Pivot Bagger CRD			
25	532 19 37-05	Tube Front Bagger CRD			

**NOTE:** All component dimensions given in U.S. inches  
1 inch = 25.4 mm

