



**REPAIR PARTS MANUAL**  
**MODEL NO. MBA15T107A**  
**Lawn Tractor**

---

**Mr. Bricolage**

# HOW TO USE THIS MANUAL

This manual is designed to provide the customer with a means to identify the parts on his/her tractor when ordering repair parts. The illustrations may or may not represent the actual assemblies; therefore, it is not recommended to use this manual as a guide to assemble or disassemble the tractor. Some hardware and parts are drawn larger in order to more readily identify them.

Each tractor has its own model number.

The model number for your tractor can be found on the fender under the seat.

When ordering parts, always give the following information:

- Product - "Lawn Tractor"
- Model Number - "MBA15T107A"
- Part Number
- Part Description

## TABLE OF CONTENTS

<b>ELECTRICAL</b> .....	<b>4-5</b>
<b>CHASSIS AND ENCLOSURES</b> .....	<b>6-7</b>
<b>DRIVE</b> .....	<b>8-9</b>
<b>SEAT</b> .....	<b>10</b>
<b>DECALS</b> .....	<b>11</b>
<b>STEERING WHEEL</b> .....	<b>12-13</b>
<b>ENGINE</b> .....	<b>14-15</b>
<b>MOWER LIFT</b> .....	<b>16-17</b>
<b>MOWER DECK</b> .....	<b>18-19</b>

# REPAIR PARTS

## TRACTOR - - MODEL NUMBER MBA15T107A

### ELECTRICAL

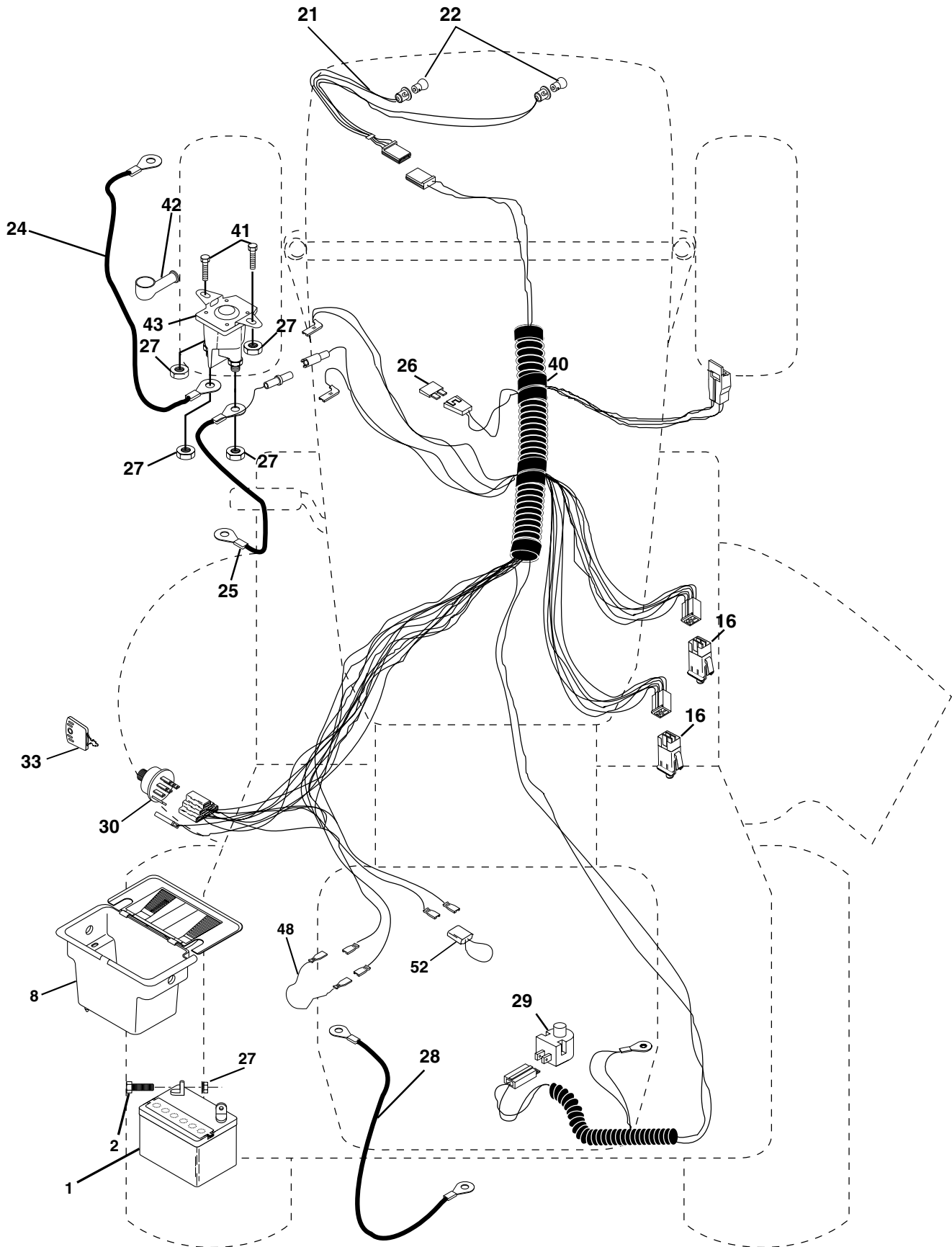

# REPAIR PARTS

## TRACTOR - - MODEL NUMBER MBA15T107A

### ELECTRICAL

KEY NO.	PART NO.	DESCRIPTION
1	144925	Battery 12 Volt 25 AMP
2	74760412	Bolt Hex Hd 1/4-20unc X 3/4
8	156417	Case Battery
16	153664	Switch Interlock Push-In
21	166181	Harness Asm Light W/4152j
22	4152J	Bulb Light #1156
24	108423X	Cable Battery
25	146147	Cable Battery 6 Ga 44" red
26	175158	Fuse
27	73510400	Nut Keps Hex 1/4-20 Unc
28	4207J	Cable Ground 6 Ga 12" black
29	121305X	Switch Plunger Nc Gray
30	175566	Switch Ign
33	140401	Key Ign
40	170217	Harness Ignition
41	71110408	Bolt Blk Fin Hex 1/4 - 20 x 1/2
42	131563	Cover Terminal Red
43	175141	Solenoid
48	140844	Adapter Ammeter
52	141940	Protection Wire Loop

**NOTE:** All component dimensions give in U.S. inches  
1 inch = 25.4 mm.

# REPAIR PARTS

## TRACTOR - - MODEL NUMBER MBA15T107A

### CHASSIS AND ENCLOSURES

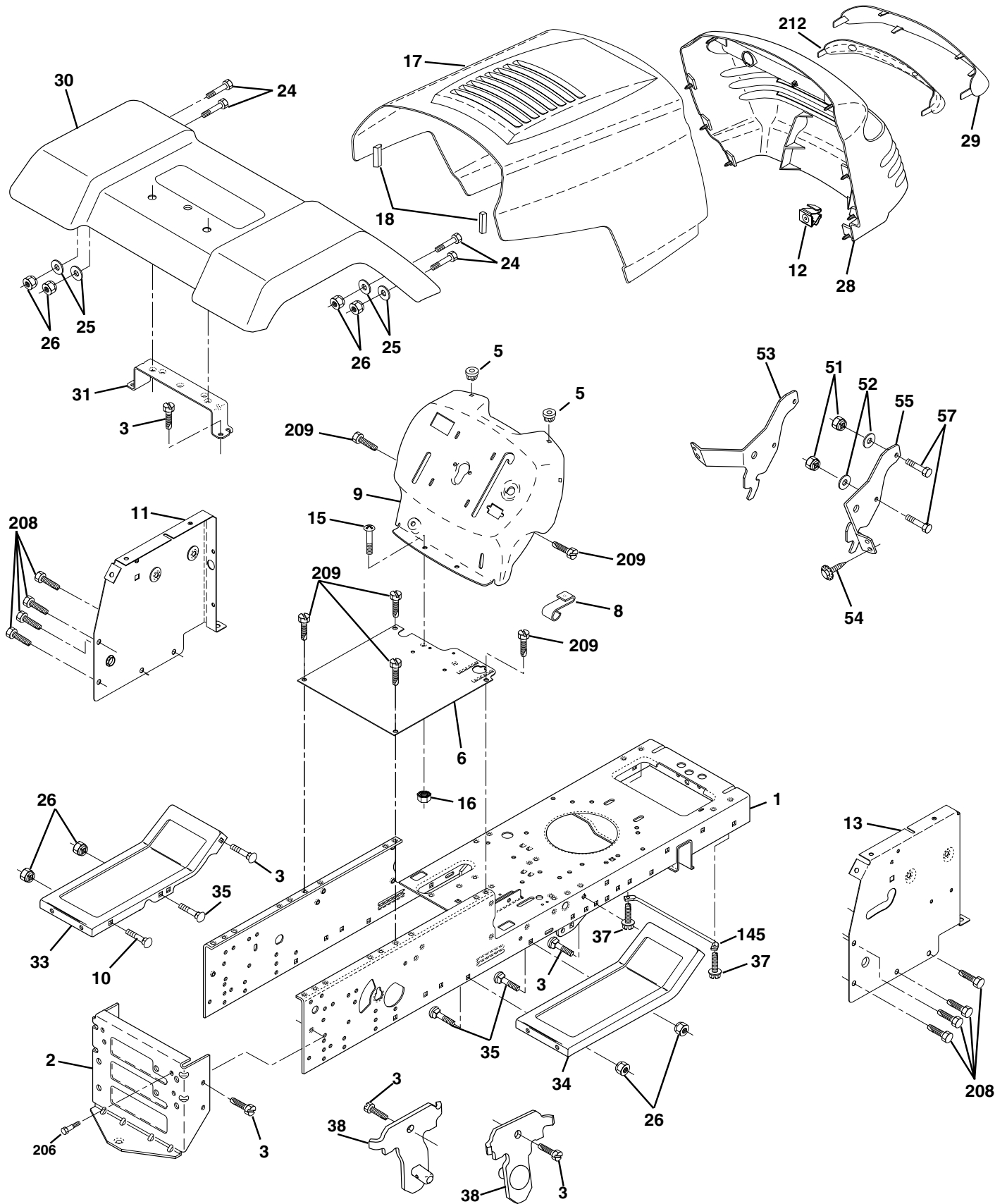

# REPAIR PARTS

## TRACTOR - - MODEL NUMBER MBA15T107A

### CHASSIS AND ENCLOSURES

KEY NO.	PART NO.	DESCRIPTION
1	169831	Chassis
2	169061	Drawbar
3	17060612	Screw, 3/8-16 x 3/4 SMGML Tap/R
5	155272	Bumper Hood/Dash
6	155924X011	Saddle Flat
8	155138	Clip Retainer Slide-On
9	168347X011	Dash P/L
10	72140608	Bolt, Rdhd Sqnk 3/8-16 x 1
11	155927	Panel Asm. Dash LH
12	145660	Clip Tinnerman Grille P/L
13	172107X010	Dash, Panel RH
15	74180512	Screw Mach. Trhd 5/16-18 UNC x 3/4
16	73510500	Nut Keps 5/16-18 UNC
17	159639X558	Hood Pnt Stl PL
18	126938X	Bumper Hood
24	74780616	Bolt, Hex , Fin. 3/8-16UNC x 1 Gr. 5
25	19131312	Washer 13/32 x 13/16 x 12 Gauge
26	73800600	Nut Lock Hex w/Ins. 3/8-16 Unc
28	150407	Grille/Lens Asm
29	150209X599	Lens Grille
30	169465X558	Fender Pnt
31	136619	Bracket Fender
33	105476X558	Footrest Pnt., LH
34	105475X558	Footrest Pnt., RH
35	72110606	Bolt Rdhd Sht. Sqnk 3/8-16 X 3/4
37	17490508	Screw Thdrol 5/16-18 x 1/2 Tyt
38	169834	Bracket Asm Pivot Mower Rear
51	73800400	Nut Lock Hex W/Ins 1/4-20
52	19091416	Washer 9/32 x 7/8 x 16 Ga.
53	144697	Bracket, Grille LH
54	161464	Screw Hex WSHD 8-18 x 7/8
55	144696	Bracket Grille RH
57	74780412	Bolt Fin Hex 1/4-20 x 3/4
145	156524	Rod Pivot Chassis/Hood
206	170165	Bolt Shoulder 5/16-18
208	17670608	Screw Thdrol 3/8-16 x 1/2
209	17000612	Screw Hexwsh Thdr 3/8-16 x 3/4
212	156494	Insert Lens Reflect
--	5479J	Plug Btn Blk .359 Dia Ch/Inf

**NOTE:** All component dimensions given in U.S. inches  
1 inch = 25.4 mm

# REPAIR PARTS

## TRACTOR - - MODEL NUMBER MBA15T107A

### DRIVE

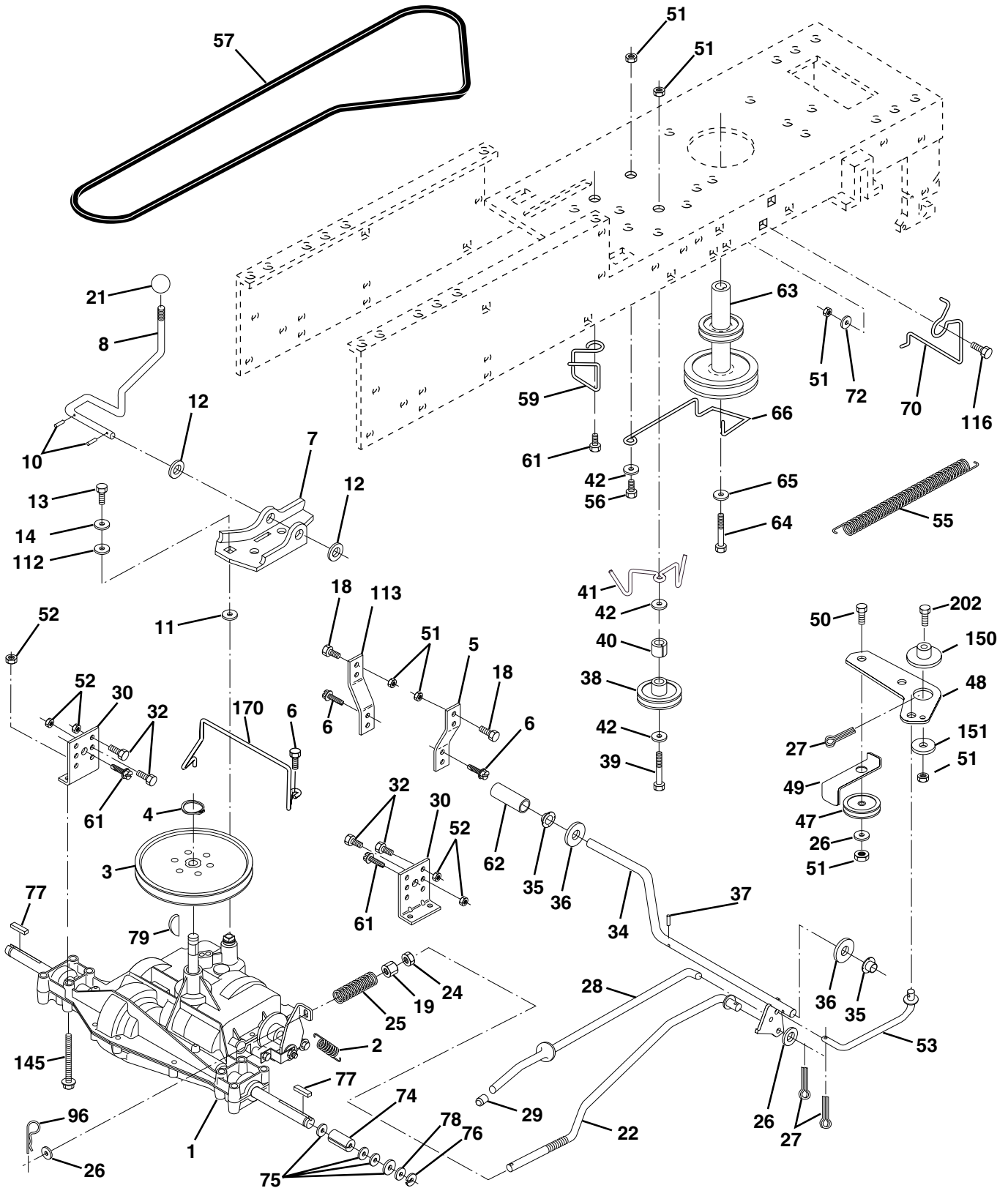

# REPAIR PARTS

## TRACTOR - - MODEL NUMBER MBA15T107A

### DRIVE

KEY NO.	PART NO.	DESCRIPTION	KEY NO.	PART NO.	DESCRIPTION
1	-----	Transaxle (See Breakdown) Peerless, Model 205-544C Order parts from transaxle manufacturer	42	19131312	Washer 13/32 x 13/16 x 12 Gauge
2	146682	Spring, Brake Return	47	127783	Pulley, Idler
3	123666X	Pulley, Transaxle	48	154407	Bellcrank Asm Clutch
4	12000028	Ring, Retainer	49	123205X	Retainer, Belt
5	121520X	Strap, Torque	50	74760624	Bolt, Hex 3/8-16 x 1-1/2
6	17060512	Screw, 5/16-18 x 3/4 SMGML	51	73680600	Nut, Crownlock 3/8-16
7	162240	Bracket, T/A, Saddle Shift	52	73680500	Nut, Crownlock 5/16-18
8	131679	Rod, Shifter	53	105710X	Link, Clutch
10	76020416	Pin, Cotter 1/8 x 1	55	105709X	Spring, Return, Clutch
11	105701X	Washer, Shift Plate	56	74760620	Bolt, Fin, Hex 3/8-16unc x 1-1/2
12	19151216	Washer 15/32 x 3/4 x 16	57	130801	V-Belt, Drive
13	74550412	Bolt 1/4-28 UNF Gr. 8 w/Patch	59	169691	Keeper Belt Center Span
14	10040400	Washer Lock	61	17060612	Screw, 3/8-16 x 3/4 SMGML
18	74780616	Bolt, Fin Hex 3/8-16 Unc x 1 Gr. 5	62	8883R	Cover, Foot Pedal
19	73800600	Locknut 3/8-16	63	140186	Pulley, Engine
21	106933X	Knob	64	71170764	Bolt, Hex 7/16-20 x 4 Gr. 5
22	130804	Rod, Brake	65	10040700	Washer, Lock Hvy Hlcl Spr 7/16
24	73350600	Nut, Hex Jam 3/8-16	66	154778	Keeper, Belt Engine F-Proof
25	106888X	Spring, Rod, Brake	70	134683	Guide Belt Mower Drive RH
26	19131316	Washer 13/32 x 13/16 x 16 Gauge	72	19132012	Washer 13/32 x 1-1/4 x 12 Ga.
27	76020412	Pin, Cotter 1/8 x 3/4	74	137057	Spacer, Split
28	145204	Rod, Brake, Park	75	121749X	Washer 25/32 x 1-1/4 x 16 Ga.
29	71673	Cap, Plunger	76	12000001	E-Ring
30	174973	Bracket, Transaxle	77	123583X	Key Square
32	74760512	Bolt Hex Hd 5/16-18 UNC x 3/4	78	121748X	Washer 25/32 x 1-5/8 x 16 Ga.
34	155071	Shaft, Foot Pedal	79	2228M	Key Woodruff #9 3/16 x 3/4
35	120183X	Bearing Nylon	96	4497H	Retainer Spring 1" Ziinc/Cad
36	19211616	Washer 21/32 x 1 x 16 Gauge	112	19091210	Washer 9/32 x 3/4 x 10 Ga.
37	1572H	Pin, Roll 3/16 x 1	113	127285X	Strap Torque L.H. Lt
38	131494	Idler, Flat	116	72110610	Bolt, RdHd Sq Neck 3/8-16 x 1.25
39	74760644	Bolt Fin Hex 3/8-16unc x 2-3/4	145	74490540	Bolt, Hex Flghd 5/16-18 Gr. 5
40	4470J	Spacer	150	165850	Bushing, Bellcrank Grd Dr.
41	165838	Keeper, Belt	151	19133210	Washer 13/32 x 2 x 10 Ga.
			170	173898	Keeper Belt T/A
			202	72110612	Bolt Carr Sh 3/8-16 x 1-1/2 Gr. 5

**NOTE:** All component dimensions give in U.S. inches.  
1 inch = 25.4 mm.



# REPAIR PARTS

## TRACTOR - - MODEL NUMBER MBA15T107A

### SEAT

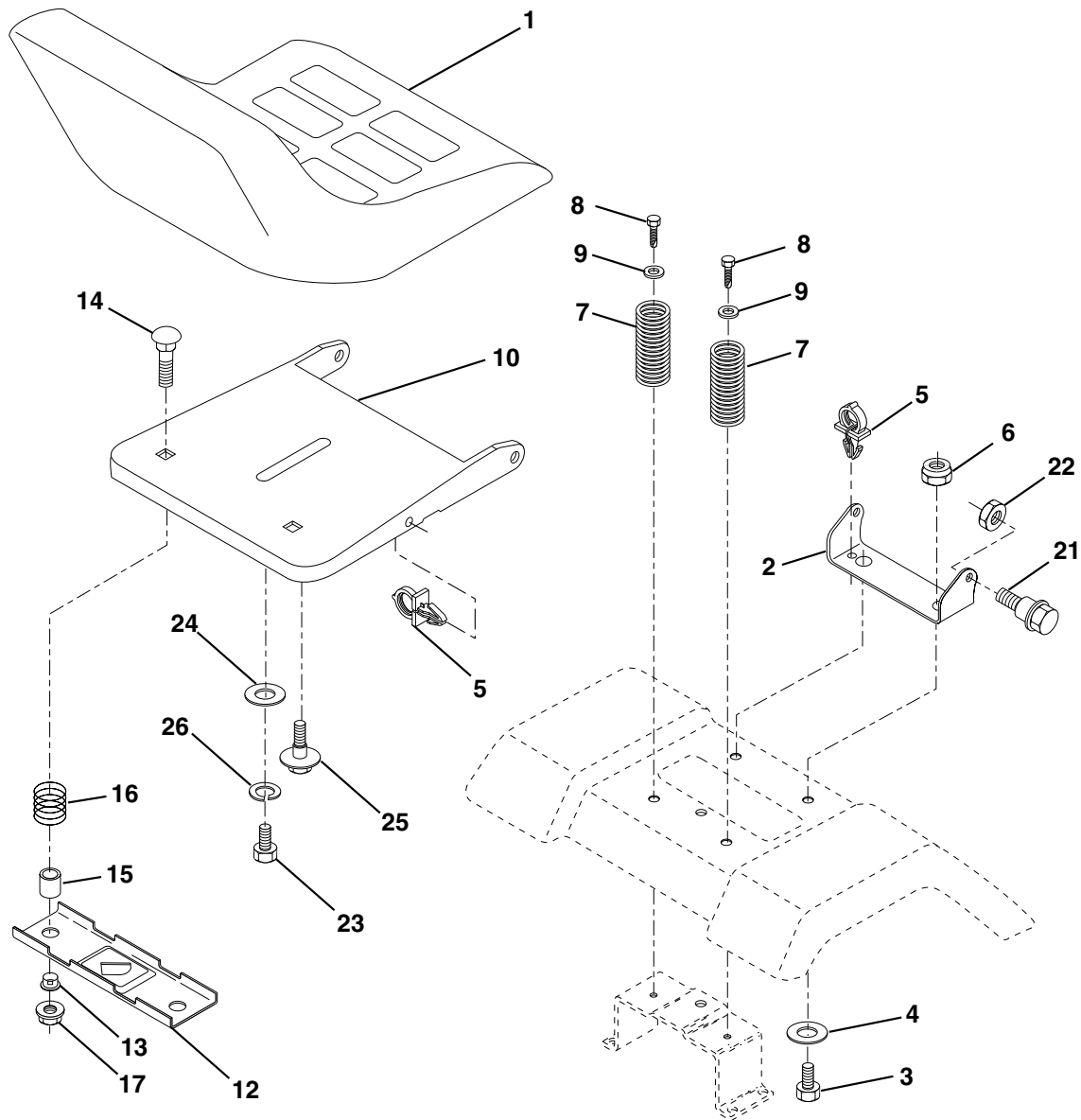

KEY NO.	PART NO.	DESCRIPTION
1	175389	Seat
2	140551	Bracket, Pivot, Seat
3	71110616	Fin Hex 3/8-16unc x 1
4	19131610	Washer 13/32 x 1 x 10 Ga.
5	145006	Clip, Push-in
6	73800600	Nut
7	124181X	Spring, Seat
8	17000616	Screw, 3/8-16 x 1.5 SMGML Tap/R
9	19131614	Washer 13/32 x 1 x 14 Ga.
10	174894	Pan, Seat
12	121246X	Bracket, Mounting, Switch, Seat
13	121248X	Bushing, Nylon

KEY NO.	PART NO.	DESCRIPTION
14	72050412	Nut, Crownlock 1/4-20 x 1-3/8
15	134300	Spacer, Split
16	121250X	Spring
17	123976X	Nut, Lock, Flange 1/4 Gr. 5
21	171852	Bolt, Shoulder 5/16-18 UNC-2A
22	73800500	Nut
23	71110814	Bolt Hex Black
24	19171912	Washer 17/32 x 1-3/16 x 12 Ga.
25	127018X	Bolt Shoulder 5/16-18 x .62
26	10040800	Washer Lock Hvy Hclc Spr 1/2

**NOTE:** All component dimensions given in U.S. inches  
1 inch = 25.4 mm

# REPAIR PARTS

## TRACTOR - - MODEL NUMBER MBA15T107A

### DECALS

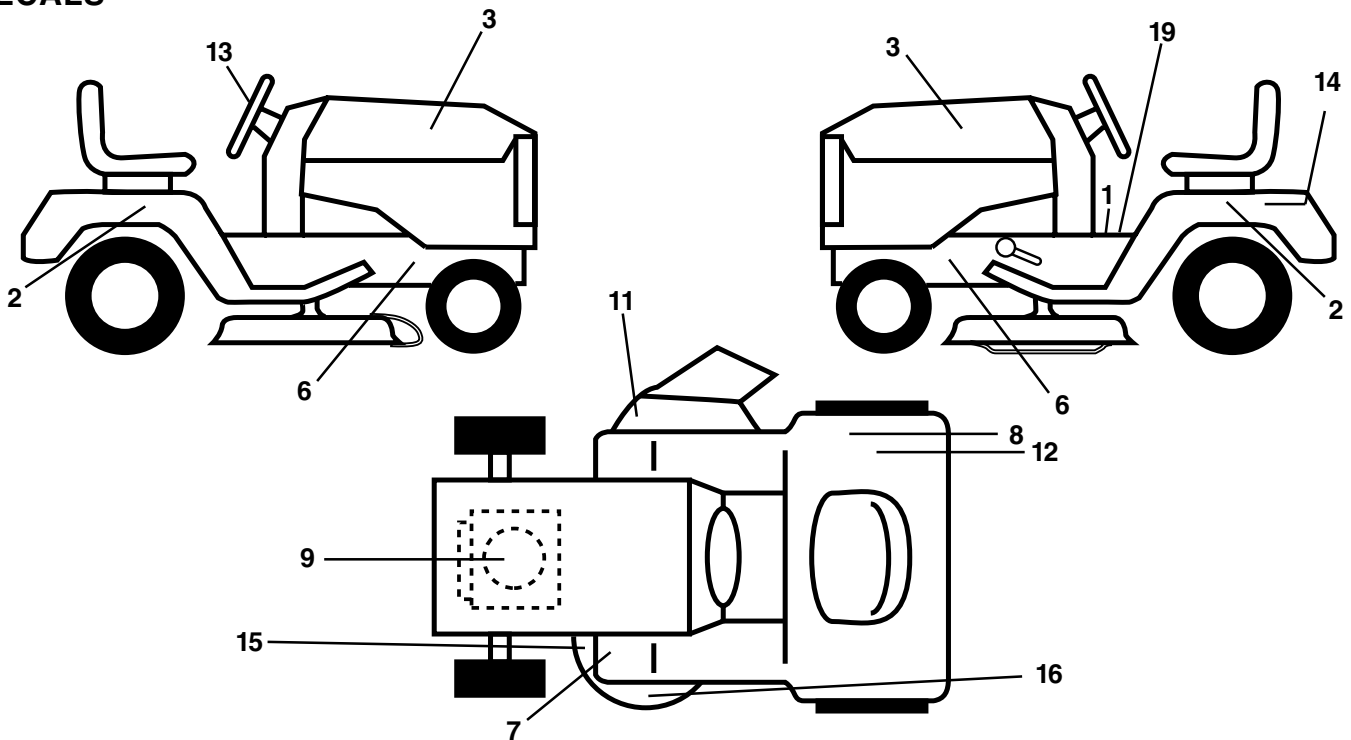

KEY NO.	PART NO.	DESCRIPTION	KEY NO.	PART NO.	DESCRIPTION
1	145498	Decal, Instruction, Operation	14	145005	Decal, Btry Dngr/Psn P/L Sym
2	176178	Decal, Fender	15	160396	Decal, V-Belt
3	171668	Decal, Hood	16	134999	Decal, Deck
6	159736	Decal, Chassis Hot Muffler	19	140837	Decal, Parking Brake
7	159737	Decal, Brake/Clutch Symbol LT	--	138311	Decal, Handle, Lift, Height Adjust (Lift Handle)
8	145437	Decal, Europe Stand CE	--	162598	Decal, Drawbar Load Limit
9	64-1730-29	Decal, HP Engine	--	176534	Manual, (Euro) Operator's
11	145494	Decal, Mower Cuttingfinger Symbol	--	176535	Manual, Repair Parts
12	126187X	Decal 100 DBA			
13	167970	Decal, Wheel Steering			

### TIRES AND WHEELS

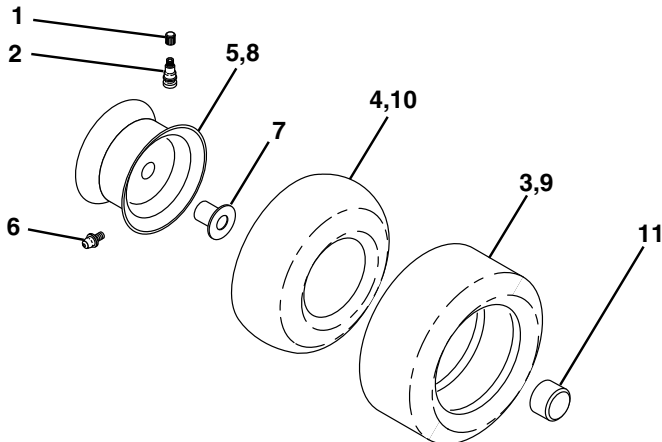

KEY NO.	PART NO.	DESCRIPTION
1	59192	Cap, Valve
2	65139	Stem, Valve
3	106222X	Tire Front
4	59904	Tube, Front (not furnished)
5	106732X427	Rim, Asm. Front
6	278H	Grease Fitting (rear tire only)
7	9040H	Bearing, Flange (front tire only)
8	106108X427	Rim, Asm. Rear
9	124635X	Tire, Rear
10	7152J	Tube, Rear (not furnished)
11	104757X428	Cap, Axle
--	144334	Sealant, Tire (10 oz. Tube)

**NOTE:** All component dimensions given in U.S. inches  
1 inch = 25.4 mm

# REPAIR PARTS

## TRACTOR - - MODEL NUMBER MBA15T107A

### STEERING WHEEL

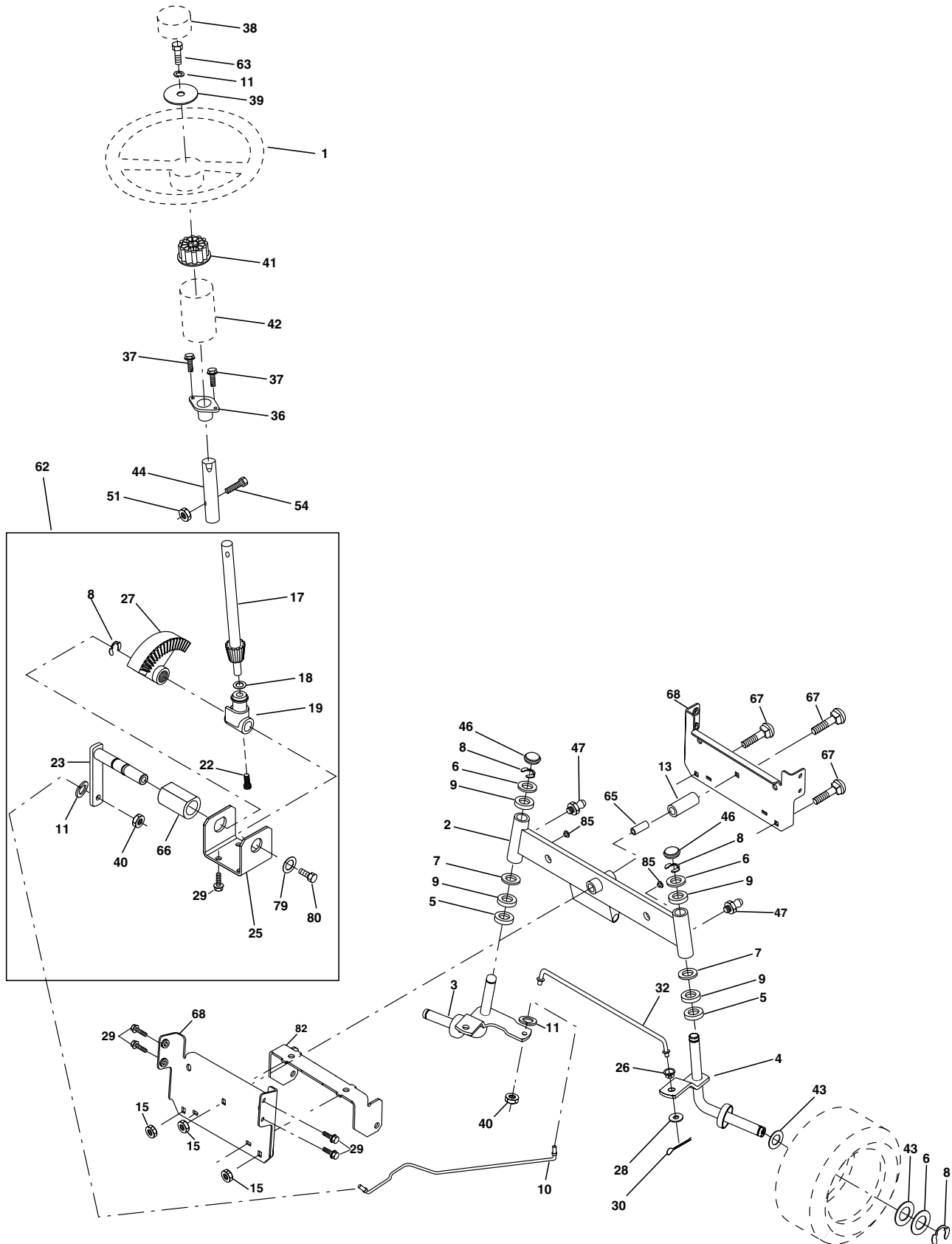

# REPAIR PARTS

## TRACTOR - - MODEL NUMBER MBA15T107A

### STEERING WHEEL

KEY NO.	PART NO.	DESCRIPTION
1	139768	Wheel Steering
2	154427	Axle Asm Front
3	169840	Spindle Asm LH
4	169839	Spindle Asm RH
5	6266H	Bearing, Race, Thrust Hardened
6	121748X	Washer 25/32 X 1-5/8 X 16 Ga
7	19272016	Washer 27/32 X 1-1/4 X 16 Ga
8	12000029	Ring Klip
9	3366R	Bearing
10	169832	Link Drag
11	10040600	Washer Lock Hvy Hlcl Spr 3/8
13	136518	Spacer Brg. Axle Front
15	145212	Nut Hexflange Lock
17	156546	Steering, Assembly Shaft
18	57079	Washer Thrust 515x 750x 033
19	160395	Support Shaft
22	165857	Screw Hex WSHHD Torx
23	165851	Shaft Asm Pittman
25	154406	Bracket Steering
26	126847X	Bushing Link Drag Blk Lr
27	136874	Gear Sector
28	19131416	Washer 13/32 x 7/8 x 16 Ga.
29	17060612	Screw 3/8-16x3/4 SMGML Tap/R
30	76020412	Pin Cotter 1/8 x 3/4 CAD
32	130465	Rod Connecting
36	155099	Bushing Steering
37	152927	Screw TT #10-32 X 5 x 3/8 Flange
38	140175	Cap Wheel Steering
39	19133812	Washer 13/32 x 2-3/8 x 12 Ga
40	7810H	Nut Lock Center 3/8-24 Unf
41	100711L	Adapter Wheel Strg
42	145054X428	Boot Steering
43	121749X	Washer 25/32 X 1 1/4 X 16 Ga
44	153720	Extension Steering
46	121232X	Cap Spindle
47	6855M	Fitting Grease
51	73800500	Nut Lock Hex W/Ins. 5/16-18 Unc P
54	74780520	Bolt Fin Hex 5/16-18 Unc 6 x 1-1/4
62	167902	Kit Steering Asm. Service
63	74780616	Bolt Fin Hex 3/8-16unc x 1 Gr. 5
65	160367	Spacer Brace Axle
66	154404	Bearing Arm Pittman
67	72140618	Bolt RDHD SQ 3/8-16UNC x 2-1/4
68	169827	Brace Axle
79	19132012	Washer 13/32 x 1-1/4 x 12
80	74950612	Bolt, Hex Nylon 3/8-16 x 3/4
82	169835	Bracket Susp. Chassis Front
85	133835	Fastener Christmas Tree

**NOTE:** All component dimensions given in U.S. inches  
1 inch = 25.4 mm

# REPAIR PARTS

## TRACTOR - - MODEL NUMBER MBA15T107A

### ENGINE

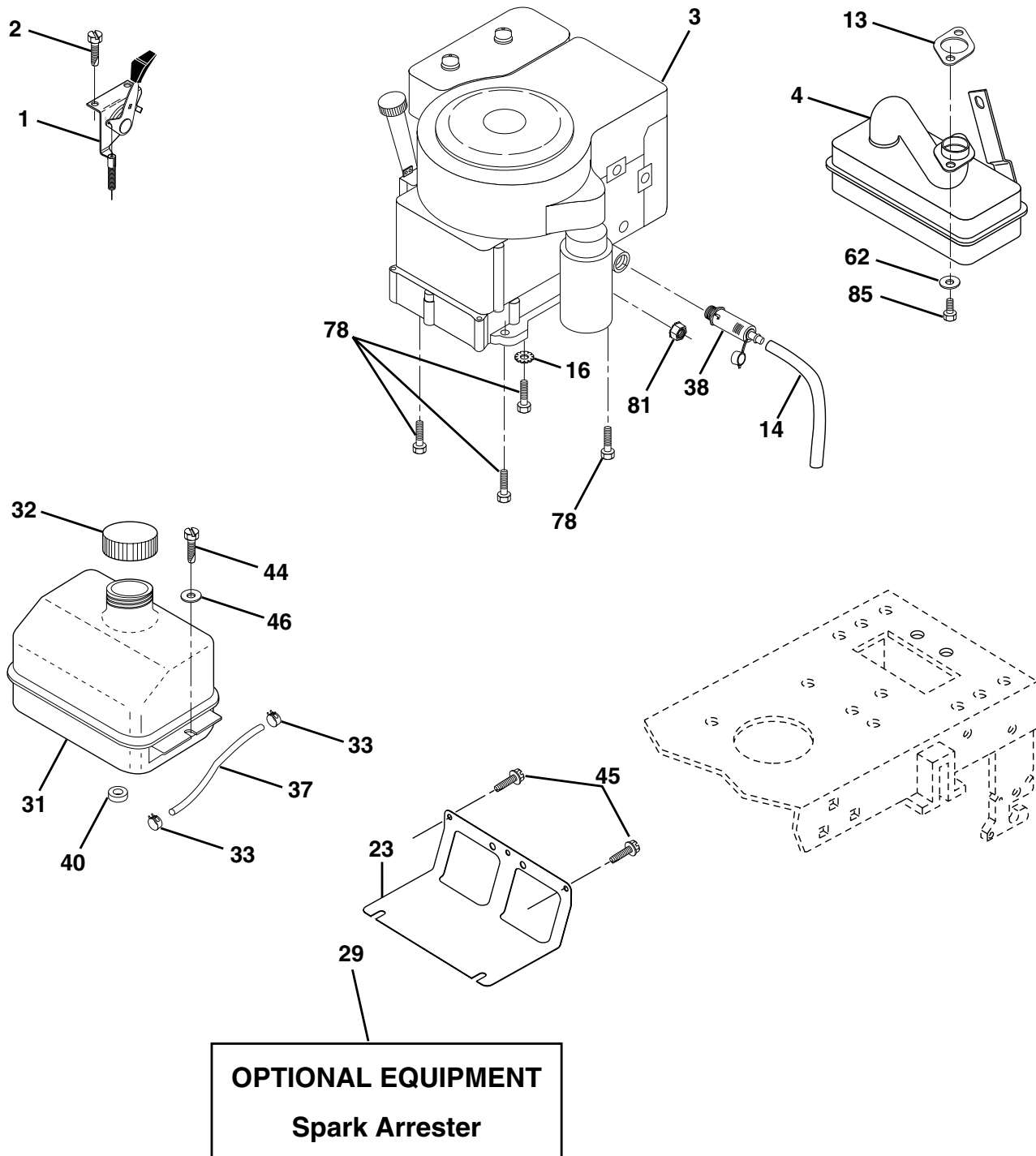

# REPAIR PARTS

## TRACTOR - - MODEL NUMBER MBA15T107A

### ENGINE

KEY NO.	PART NO.	DESCRIPTION
1	170551	Control Th/ch
2	17720410	Screw Hex Thd Cut 1/4-20x5/8 T
3	-----	Engine, Tecumseh Model OHV165 Order parts from engine manufacturer
4	137351	Muffler Exhaust
13	149272	Gasket Muffler
14	148456	Tube Drain Oil Easy
15	13200300	Elbow Std 90 Degree 3/8-18 Npt
16	11050600	Washer Lock Ext Tooth 3/8
23	169837	Shield BRN/DBR Guard
29	137180	Kit Spark Arrestor (Flat Scrm)
31	109202X	Tank Fuel Front
32	140527	Cap Asm Fuel
33	123487X	Clamp Hose Blk
37	137040	Line Fuel
38	148315	Plug Drain Oil Easy
40	124028X	Bushing Snap Nyl Blk Fuel Line
44	17670412	Screw Hexwsh Thdrol 1/4-20x3/4
45	17000612	Screw Hex Wsh Thdrol 3/8-16
46	19091416	Washer 9/32 X 7/8 X 16 Ga
62	10040500	Washer 5/16
78	17060620	Screw 3/8-16x1-1/4 SMGML Tap/R
81	73510400	Nut Keps Hex 1/4-20 UNC
85	123528X	Bolt, Hex Hd Phillips

**NOTE:** All component dimensions given in U.S. inches.  
1 inch = 25.4 mm.

# REPAIR PARTS

TRACTOR - - MODEL NUMBER MBA15T107A

## MOWER LIFT

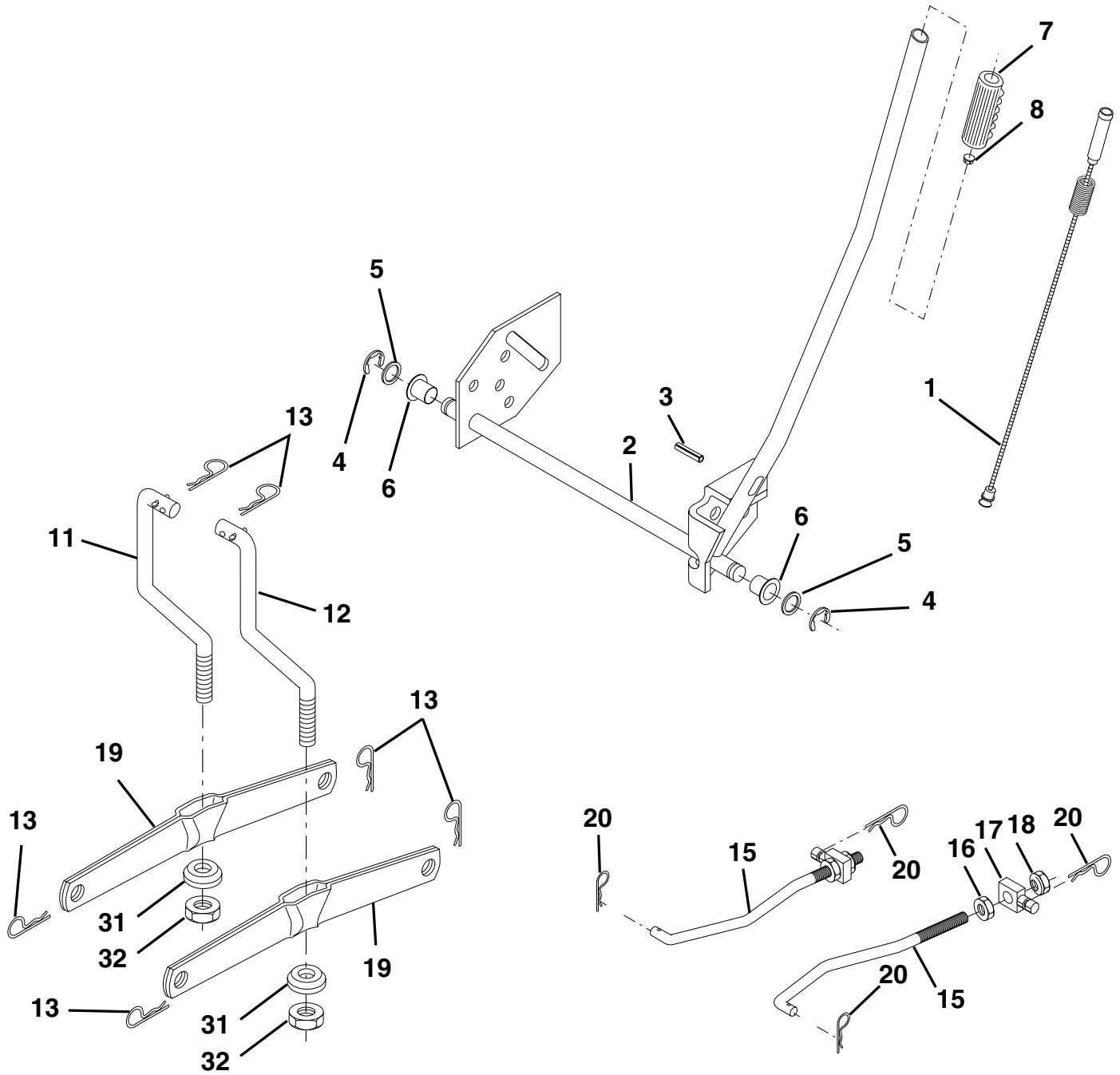

# REPAIR PARTS

## TRACTOR - - MODEL NUMBER MBA15T107A

### MOWER LIFT

KEY NO.	PART NO.	DESCRIPTION
1	159460	Wire Asm. Inner/Sprg w/Plunger
2	159471	Shaft, Asm., Lift R/H
3	105767X	Pin, Groove
4	12000002	Ring, E #5133-62
5	19211621	Washer 21/32 x 1 x 21 Ga.
6	120183X	Bearing, Nylon
7	109413X	Grip Handle Bicycle Matte Blk
8	124526X	Button, Plunger
11	139865	Link, Lift, Lh
12	139866	Link, Lift, Rh
13	4939M	Spring, Retainer
15	173288	Link, Front
16	73350800	Nut, Jam, Hex 1/2-13 Unc
17	130171	Trunnion
18	73800800	Nut Lock W/Wsh 1/2-13 Unc
19	139868	Arm, Suspension, Rear
20	163552	Spring, Retainer Zinc
31	169865	Bearing, Pvt Lft
32	73540600	Nut Crownlock 3/8-24

**NOTE:** All component dimensions given in U.S. inches  
1 inch = 25.4 mm



# REPAIR PARTS

## TRACTOR - - MODEL NUMBER MBA15T107A

### MOWER DECK

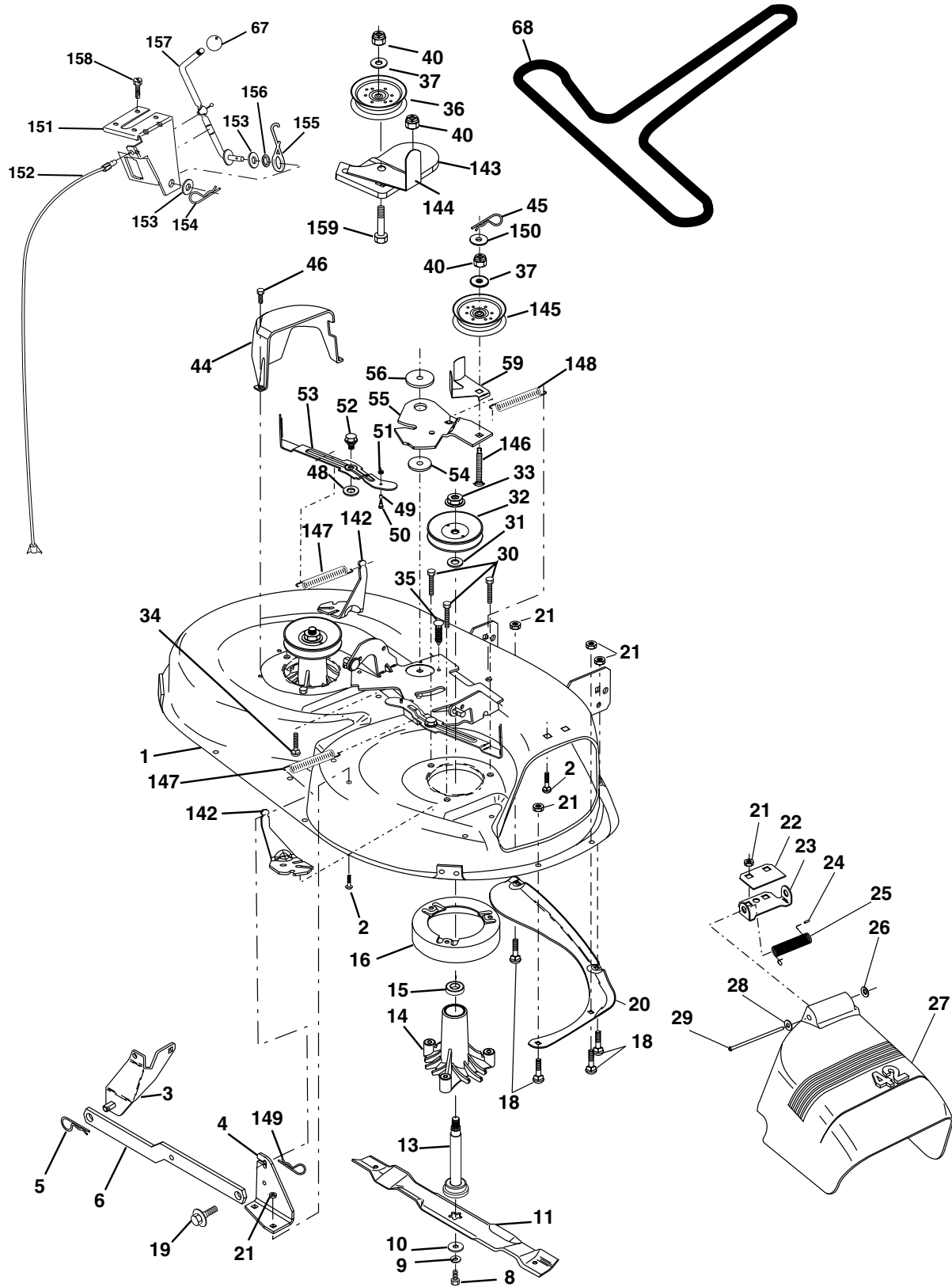

# REPAIR PARTS

## TRACTOR - - MODEL NUMBER MBA15T107A

### MOWER DECK

KEY NO.	PART NO.	DESCRIPTION	KEY NO.	PART NO.	DESCRIPTION
1	165892	Housing Asm MWR 42" Path	45	4497H	Spring Retainer 1" Zinc/cad
2	72140506	Bolt Rdhd Sqnk 5/16-18unc X3/4	46	137729	Screw Hex Thd Cut 1/4-24 UNC
3	138017	Bracket Asm Fr Sway Bar 38/42	48	133944	Washer Hardened Smaller
4	165460	Bracket Asm Deck 42"sway Bar	49	174284	Roller Asm Cam Follower 42"dec
5	4939M	Retainer Spring	50	131340	Bolt Shldr 10-24 Zinc Gr 5 42"
6	130832	Arm Suspension Rear	51	69180	Nut Lock #10-24 Unc
8	850857	Bolt 3/8-24x1 25 Gr8 Patched	52	139888	Bolt Shoulder 5/16-18 Unc Blkz
9	10030600	Washer Lock Hvy 3/8 Unplated	53	131845	Arm Asm Pad Brake
10	140296	Washer Hard Blade Mower Vented	54	133943	Washer Hardened
11	138498	Blade Mower	55	155046	Arm Idler 42" mower
12	129895	Bearing Ball #6204 (Mandrel)	56	165723	Spacer Retainer Pm Mower
13	137645	Shaft Asm W/lower Bearing	59	141043	Guard TUV Idler
14	128774	Housing Mandrel Vented(machd)	67	106932X	Knob
15	110485X	Bearing Ball Mandrel	68	144959	V-Belt Mower
16	140329	Stripper Mower Round	142	165890	Arm Spring Brake Mower
18	72140505	Bolt Carr 5/16-18 X 5/8	143	157109	Bracket Arm Idler 42"
19	132827	Bolt Shoulder	144	158634	Keeper Belt 42" Clutch Cable
20	159770	Baffle Vortex 42	145	165888	Pulley Idler Flat
21	73680500	Nut Crown Lock 5/16-18	146	171977	Bolt Carriage Idler
22	134753	Stiffener Bracket 42"deck	147	131335	Spring Extension
23	131267	Bracket Deflector Mower 42"	148	169022	Spring Return Idler
24	105304X	Cap Sleeve 80x 112 Blk Mower	149	165898	Retainer Srpng Yellow Zinc
25	123713X	Spring Torsion Deflector 2 52	150	19091216	Washer 9/32 x 3/4 x 6 Ga.
26	110452X	Nut Push Phos & Oil	151	169670	Bracket Clutch
27	130968X428	Shield Deflector Mower 42" Blk	152	169676	Cable Clutch 42 in
28	19111016	Washer 11/32 X 5/8 X 16 Ga	153	169674	Washer Flat 3/8" Type B
29	131491	Rod Hinge 42"6 75 Wlg	154	169675	Spring Retainer
30	157722	Screw Thdrol Washer Hd	155	169671	Spring Retention Lever
31	129963	Washer Spacer Mower Vented	156	169672	Spacer
32	153535	Pulley Mandrel 42/44/50"	157	169669	Rod Clutch
33	137266	Nut 9/16top Lock Flng	158	17720410	Screw Hex Thd Cut 1/4-20 x 5
34	72110614	Bolt Rdhd 3/8-16uncx1-3/4 Gr5	159	72140614	Bolt RDHD Sqn 3/8-16 x 1-3/4
35	133835	Fastner Christmas Tree	--	130794	Mandrel Assembly (Includes Key
36	131494	Pulley Idler Flat 3 060			Numbers 8-10, 12-15, 31 and 33)
37	19131316	Washer 13/32 x 13/16 x 16 Ga.	--	171639	Deck, Std (Complete)
40	73680600	Nut Crownlock 3/8-16 Unc			
44	140088	Guard Mandrel LH Black			

**NOTE:** All component dimensions given in U.S. inches  
1 inch = 25.4 mm

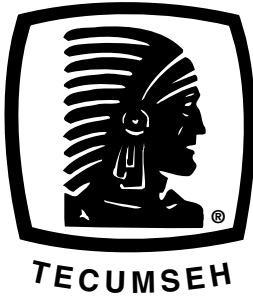

# SERVICE POLICY WARRANTY

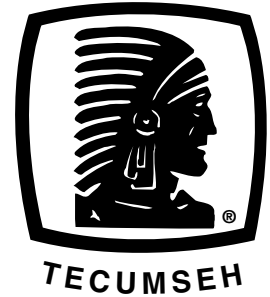

Issued January 1980  
Revised January 1991

## LIMITED WARRANTIES FOR NEW PEERLESS GEAR POWER TRAIN COMPONENTS

### A. Products Warranted

Peerless Gear and Machine Division of Tecumseh Products Company ("Tecumseh"), subject to the limitations contained below, at its option, repair or replace, without charge for parts or labor only, any part of a new Power Train Component (which as used herein means and includes the transaxle, gear box, transmission, differential and right angle drives, and any part of the Power Train Component), EXCEPT any new Power Train Component incorporated in equipment used for commercial or rental purposes, which is found upon examination by any Tecumseh Authorized Service Outlet or by Tecumseh's factory in Grafton, Wisconsin, to be DEFECTIVE IN MATERIAL AND/OR WORKMANSHIP if received by Tecumseh or a Tecumseh Authorized Service Outlet for such examination within TWO YEARS from the date of sale to the original consumer purchaser of Peerless Series 820, 900, 910, 915, 920, 930 transaxles and Series 1100 angle drive and ONE YEAR for all other Peerless products. New Power Train Components incorporated in equipment used for commercial purposes are warranted in the same manner and to the same extent EXCEPT such Power Train Components are warranted for NINETY (90) DAYS ONLY, and must be received by Tecumseh or by a Tecumseh Authorized Service Outlet for such examination within 90 days from the date of sale to the original purchaser. New Power Train Components incorporated in equipment used for rental purposes are warranted in the same manner and to the same extent EXCEPT such Power Train Components are warranted for THIRTY (30) DAYS ONLY, and must be received by Tecumseh or a Tecumseh Authorized Service Outlet within 30 days from the date of sale to the original purchaser.

### B. Products And Items Not Warranted

1. Alterations or Modifications of Power Train Components.
2. Accidents, Normal Maintenance, Failure to follow the Original Equipment Manufacturer's Manual.

This warranty covers only parts of new Power Train Components which are found upon examination to be defective in material or workmanship as delivered to the original purchaser. This warranty does not cover defects caused by depreciation or damage caused by normal wear, accidents, improper maintenance, improper use or abuse of the product, failure to follow the instructions contained in an Instruction Manual for the operation of the Power Train Component and parts. The cost of normal maintenance and replacement of service items which are not defective shall be paid for by the original purchaser.

### C. Securing Warranty Service

Warranty service can be arranged for by contacting either a Tecumseh Authorized Service Outlet (any Tecumseh Registered Service Dealer, Tecumseh Authorized Service Distributor, or Tecumseh Central Warehouse Distributor) or by contacting Tecumseh, c/o Service Manager, Engine and Transmission Group Service Division, 900 North Street, Grafton, Wisconsin 53024. Warranty service can only be performed by a Tecumseh Authorized Service Outlet or by Tecumseh at its factory in Grafton, Wisconsin. At the time of requesting warranty service, evidence must be presented of the date of sale to the original purchaser. The purchaser shall pay any charges for making service calls and/or for transporting the product to and from the place where the inspection and/or warranty work is performed. The purchaser shall be responsible for any damage or loss incurred in connection with the transportation of Power Train Components and/or part(s) of the Power Train Components submitted for inspection and/or warranty work.

### D. Limitation of Damages and Implied Warranties

The foregoing EXPRESSED WARRANTY IS IN LIEU OF ALL OTHER EXPRESS WARRANTIES. Neither Tecumseh nor any of its affiliates makes any warranties, representations or promises, written or oral, as to the quality of the Power Train Component or any of its parts, other than as set forth herein.

ANY IMPLIED WARRANTY OF MERCHANTABILITY OR FITNESS FOR A PARTICULAR PURPOSE, TO THE EXTENT THAT EITHER MAY APPLY TO ANY PART(S) OF POWER TRAIN COMPONENTS, SHALL BE LIMITED IN DURATION TO THE PERIODS OF THE EXPRESSED WARRANTIES DEFINED IN PARAGRAPH A HEREOF. IN NO EVENT WILL TECUMSEH BE LIABLE FOR ANY INCIDENTAL, CONSEQUENTIAL OR SPECIAL DAMAGES AND/OR EXPENSES. Some states do not allow limitations on how long an implied warranty lasts or the exclusion or limitation of incidental or consequential damages, so the above limitation(s) or exclusion(s) may not apply to you. This warranty gives you specific legal rights and you may also have other legal rights which vary from state to state.

### E. No Dealer Warranty

Tecumseh neither assumes nor authorizes any other person, natural or corporate, to assume for Tecumseh any other obligations or liabilities in connection with or with respect to any part(s) of a Power Train Component. The seller or dealer of part(s) of a Power Train Component has no authority, whatsoever, to make any representations or promises on behalf of Tecumseh or to modify the terms or limitations of Tecumseh's warranty in any way.