

REPAIR PARTS MANUAL
MODEL NO. RE1138A
Lawn Tractor

Rally

HOW TO USE THIS MANUAL

This manual is designed to provide the customer with a means to identify the parts on his/her tractor when ordering repair parts. The illustrations may or may not represent the actual assemblies; therefore, it is not recommended to use this manual as a guide to assemble or disassemble the tractor. Some hardware and parts are drawn larger in order to more readily identify them.

Each tractor has its own model number.

The model number for your tractor can be found on the fender under the seat.

When ordering parts, always give the following information:

- Product - "Lawn Tractor"
- Model Number - "RE1138A"
- Part Number
- Part Description

TABLE OF CONTENTS

SCHEMATIC.....	3
ELECTRICAL.....	4-5
CHASSIS AND ENCLOSURES.....	6-7
DRIVE.....	8-9
SEAT.....	10
DECALS.....	11
STEERING WHEEL.....	12-13
ENGINE.....	14
MOWER LIFT.....	15
MOWER DECK.....	16-17

TRACTOR - - MODEL NUMBER RE1138A

SCHEMATIC

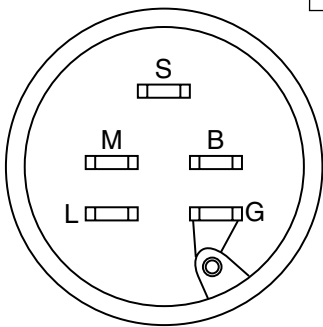
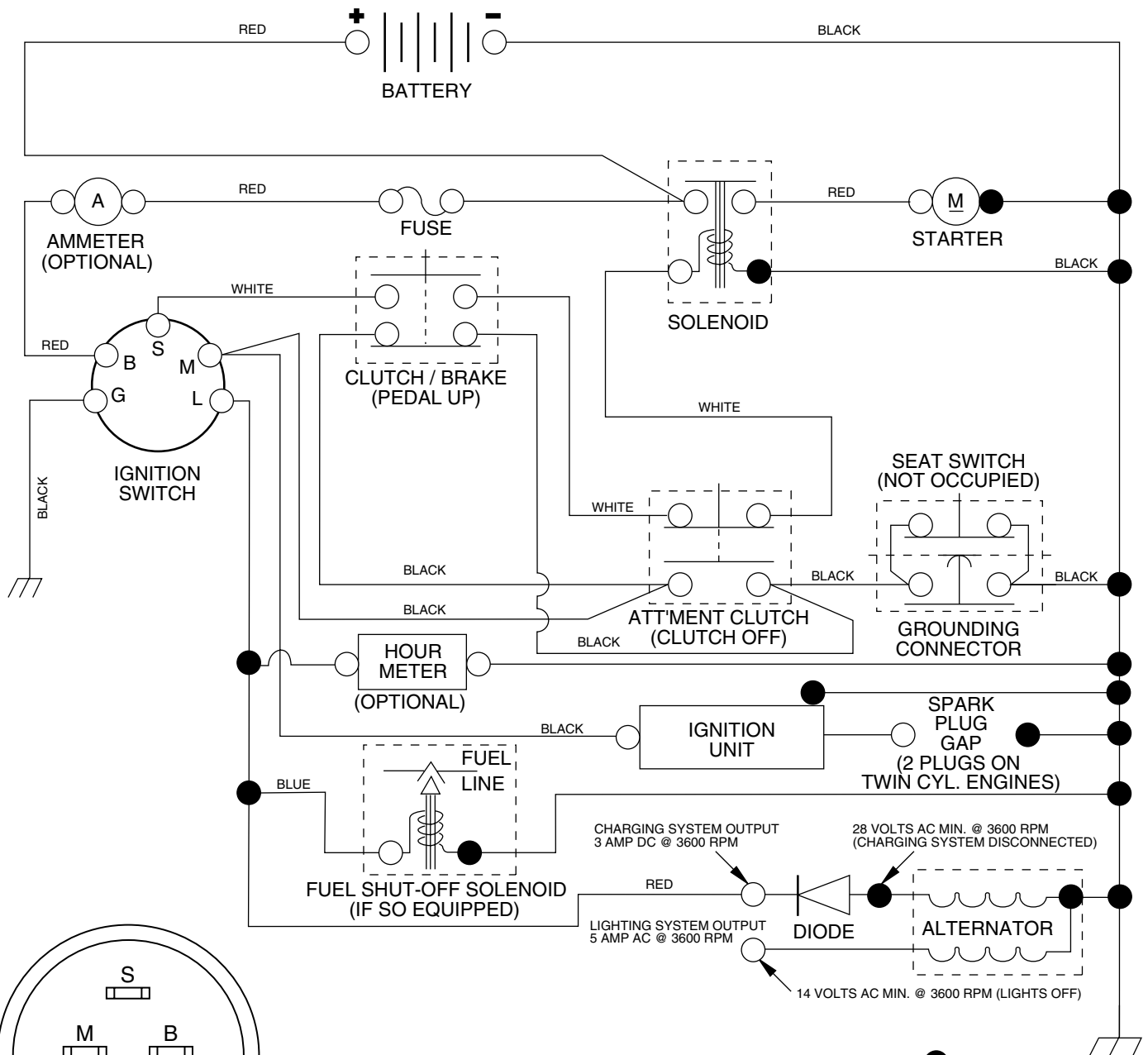

IGNITION SWITCH

POSITION	CIRCUIT
OFF	M + G
ON	B + L
START	B + S + L

WIRING INSULATED CLIPS
NOTE: IF WIRING INSULATED CLIPS WERE REMOVED FOR SERVICING OF UNIT, THEY SHOULD BE REPLACED TO PROPERLY SECURE YOUR WIRING.

●
NON-REMOVABLE CONNECTIONS

○
REMOVABLE CONNECTIONS

REPAIR PARTS

TRACTOR - - MODEL NUMBER RE1138A

ELECTRICAL

KEY NO.	PART NO.	DESCRIPTION
1	163465	Battery
2	74760412	Bolt Hex Hd 1/4-20unc X 3/4
8	176689	Box Battery Fender
16	176138	Switch Interlock
24	4799J	Cable Battery
25	146147	Cable Battery 6 Ga 44" red
26	175158	Fuse 20 AMP
27	73510400	Nut Keps Hex 1/4-20 Unc
28	4207J	Cable Ground 6 Ga 12" black
29	121305X	Switch Plunger Nc Gray
30	175567	Switch Ign
33	140401	Key Ign
40	179730	Harness Ignition
41	71110408	Bolt Blk Fin Hex 1/4 - 20 x 1/2
42	131563	Cover Terminal Red
43	178861	Solenoid
48	140844	Adapter Ammeter
52	141940	Protection Wire Loop
89	180449	Cover Terminal Battery

NOTE: All component dimensions give in U.S. inches
1 inch = 25.4 mm.

REPAIR PARTS

TRACTOR - - MODEL NUMBER RE1138A

CHASSIS AND ENCLOSURES

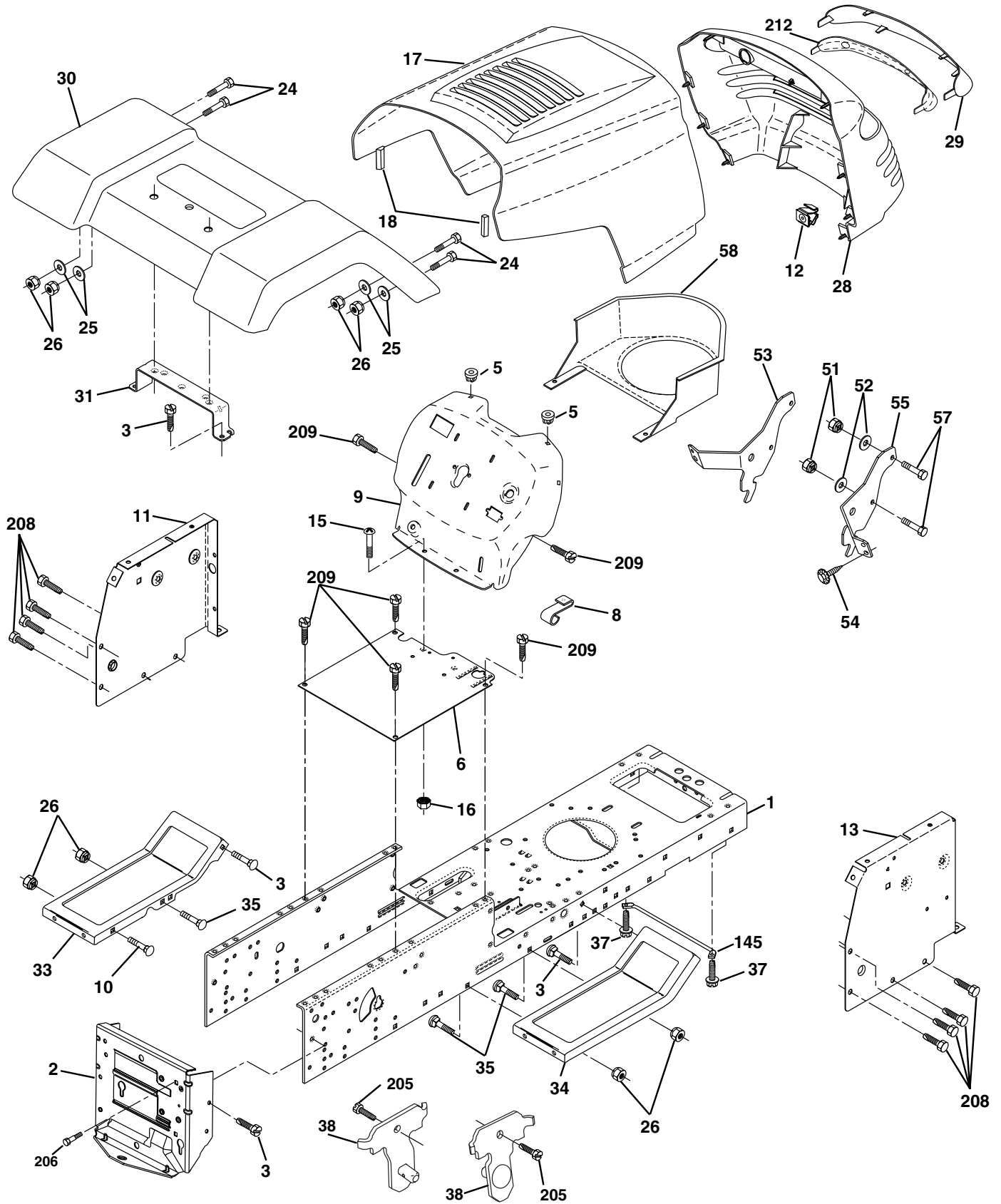

REPAIR PARTS

TRACTOR - - MODEL NUMBER RE1138A

CHASSIS AND ENCLOSURES

KEY NO.	PART NO.	DESCRIPTION
1	174620	Chassis
2	176554	Drawbar
3	17060612	Screw, 3/8-16 x 3/4 SMGML Tap/R
5	155272	Bumper Hood/Dash
6	174643X012	Saddle Flat
8	155138	Clip Retainer Slide-On
9	168347X011	Dash P/L
10	72140608	Bolt, Rdhd Sqnk 3/8-16 x 1
11	155927	Panel Asm. Dash LH
12	145660	Clip Tinnerman Grille P/L
13	172107X010	Dash, Panel RH
15	74180512	Screw Mach. Trhd 5/16-18 UNC x 3/4
16	73510500	Nut Keps 5/16-18 UNC
17	159639X505	Hood Pnt Stl PL
18	126938X	Bumper Hood
24	74780616	Bolt, Hex , Fin. 3/8-16UNC x 1 Gr. 5
25	19131312	Washer 13/32 x 13/16 x 12 Gauge
26	73800600	Nut Lock Hex w/Ins. 3/8-16 Unc
28	179780	Grille/Lens Asm.
29	150209X428	Lens Grille
30	169465X505	Fender Pnt
31	136619	Bracket Fender
33	179716X505	Footrest Pnt., LH
34	179717X505	Footrest Pnt., RH
35	72110606	Bolt Rdhd Sht. Sqnk 3/8-16 X 3/4
37	17490508	Screw Thdrol 5/16-18 x 1/2 Tyt
38	175710	Bracket Asm Pivot Mower Rear
51	73800400	Nut Lock Hex W/Ins 1/4-20
52	19091416	Washer 9/32 x 7/8 x 16 Ga.
53	144697	Bracket, Grille LH
54	161464	Screw Hex WSHD 8-18 x 7/8
55	144696	Bracket Grille RH
57	74780412	Bolt Fin Hex 1/4-20 x 3/4
58	150127	Duct Air Engine
145	156524	Rod Pivot Chassis/Hood
205	17490608	Screw Thdrol 3/8-16 x 1/2
206	170165	Bolt Shoulder 5/16-18
208	17670608	Screw Thdrol 3/8-16 x 1/2
209	17000612	Screw Hex Wsh Thdrol 3/8-16 x 3/4
212	156494	Insert Lens Reflect Quarda
--	5479J	Plug Btn Blk .359 Dia Ch/Inf

NOTE: All component dimensions given in U.S. inches
1 inch = 25.4 mm

REPAIR PARTS

TRACTOR - - MODEL NUMBER RE1138A

DRIVE

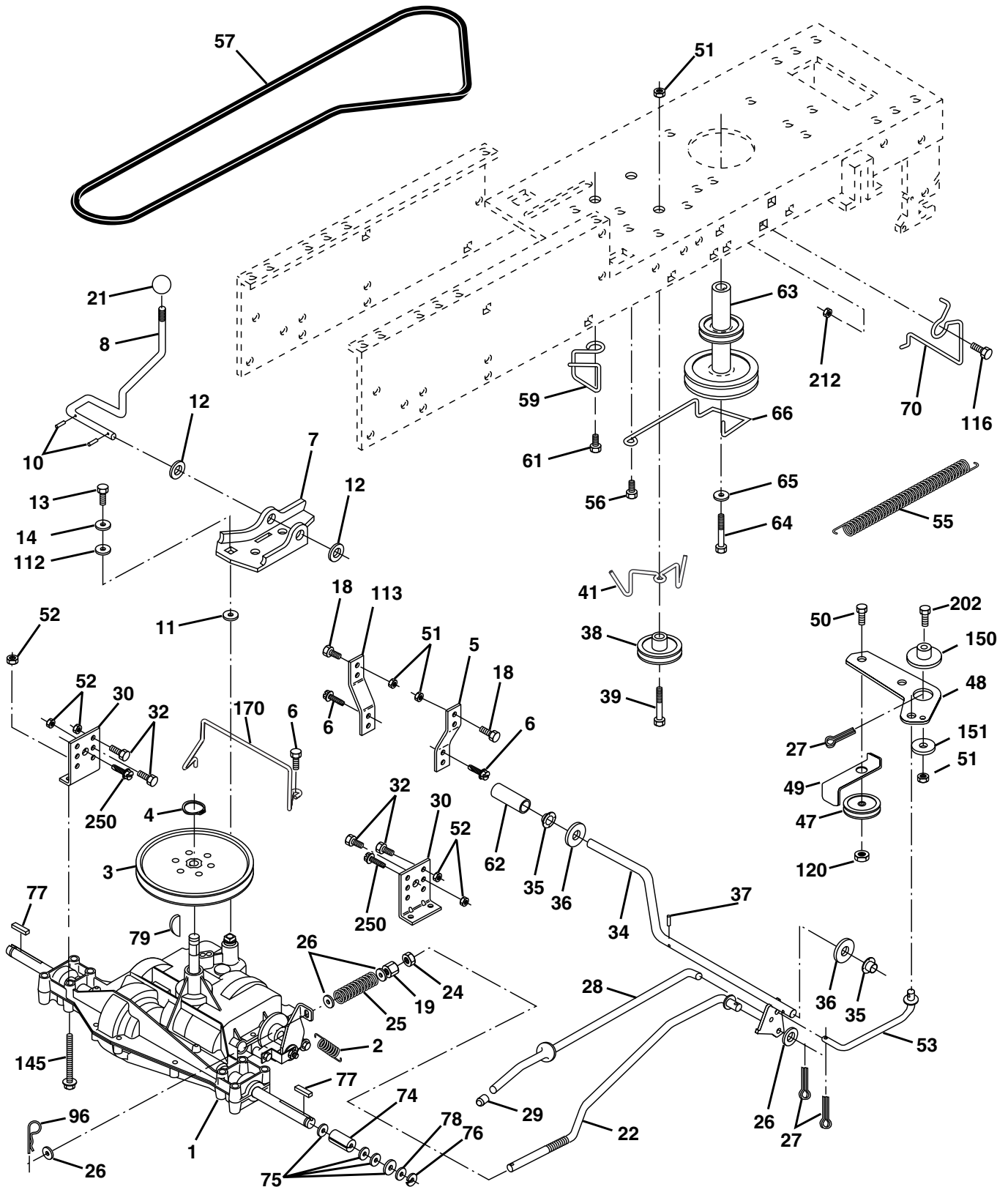

REPAIR PARTS

TRACTOR - - MODEL NUMBER RE1138A

DRIVE

KEY NO.	PART NO.	DESCRIPTION	KEY NO.	PART NO.	DESCRIPTION
1	-----	Transaxle Peerless, Model 204-506B (Order parts from transaxle manufacturer)	48	154407	Bellcrank Asm Clutch Retainer, Belt
2	146682	Spring, Brake Return	49	123205X	Bolt, Hex 3/8-16 x 1-1/2
3	123666X	Pulley, Transaxle	50	74760624	Nut, Crownlock 3/8-16
4	12000028	Ring, Retainer	51	73680500	Nut, Crownlock 5/16-18
5	121520X	Strap, Torque	52	105710X	Link, Clutch
6	17060512	Screw, 5/16-18 x 3/4 SMGML	53	105709X	Spring, Return, Clutch
7	162240	Bracket, T/A, Saddle Shift	54	17060620	Screw 3/8-16 x 1-1/4
8	131679	Rod, Shifter	55	130801	V-Belt, Drive
10	76020416	Pin, Cotter 1/8 x 1	56	169691	Keeper Belt Center Span
11	105701X	Washer, Shift Plate	57	17120614	Screw 3/8-16 x .875
12	19151216	Washer 15/32 x 3/4 x 16	58	8883R	Cover, Foot Pedal
13	74550412	Bolt 1/4-28 UNF Gr. 8 w/Patch	59	175410	Pulley, Engine
14	10040400	Washer Lock	60	71170764	Bolt, Hex 7/16-20 x 4 Gr. 5
18	74780616	Bolt, Fin Hex 3/8-16 Unc x 1 Gr. 5	61	10040700	Washer, Lock Hvy Hlcl Spr 7/16
19	73800600	Locknut 3/8-16	62	154778	Keeper, Belt Engine F-Proof
21	106933X	Knob	63	134683	Guide Belt Mower Drive RH
22	130804	Rod, Brake	64	137057	Spacer, Split
24	73350600	Nut, Hex Jam 3/8-16	65	121749X	Washer 25/32 x 1-1/4 x 16 Ga.
25	106888X	Spring, Rod, Brake	66	12000001	E-Ring
26	19131316	Washer 13/32 x 13/16 x 16 Gauge	67	123583X	Key Square
27	76020412	Pin, Cotter 1/8 x 3/4	68	121748X	Washer 25/32 x 1-5/8 x 16 Ga.
28	175765	Rod, Brake, Park	69	2228M	Key Woodruff #9 3/16 x 3/4
29	71673	Cap, Plunger	70	4497H	Retainer Spring 1" Ziinc/Cad
30	174973	Bracket, Transaxle, L.H.	71	19091210	Washer 9/32 x 3/4 x 10 Ga.
32	74760512	Bolt Hex Hd 5/16-18 UNC x 3/4	72	127285X	Strap Torque L.H. Lt
34	175578	Shaft, Foot Pedal	73	72140608	Bolt, RdHd Sq Neck 3/8-16 x 1
35	120183X	Bearing Nylon	74	73900600	Nut Lock Flg 3/8-16
36	19211616	Washer 21/32 x 1 x 16 Gauge	75	74490540	Bolt, Hex Flghd 5/16-18 Gr. 5
37	1572H	Pin, Roll 3/16 x 1	76	175456	Spacer Retainer
38	179114	Pulley, Idler	77	19133210	Washer 13/32 x 2 x 10 Ga.
39	74760648	Bolt, RDHD 3/8-16unc x 3 Gr. 5	78	173894	Keeper, Belt, Transaxle
40	175461	Spacer	79	72110614	Bolt Carr Sh 3/8-16 x 1-3/4 Gr. 5
41	175556	Keeper, Belt	80	145212	Nut Hex Flange Lock
42	19131312	Washer 13/32 x 13/16 x 12 Gauge	81	17060612	Screw, 3/8-16 x 3/4 SMGML
47	127783	Pulley, Idler			

NOTE: All component dimensions give in U.S. inches.
1 inch = 25.4 mm.

REPAIR PARTS

TRACTOR - - MODEL NUMBER RE1138A

SEAT

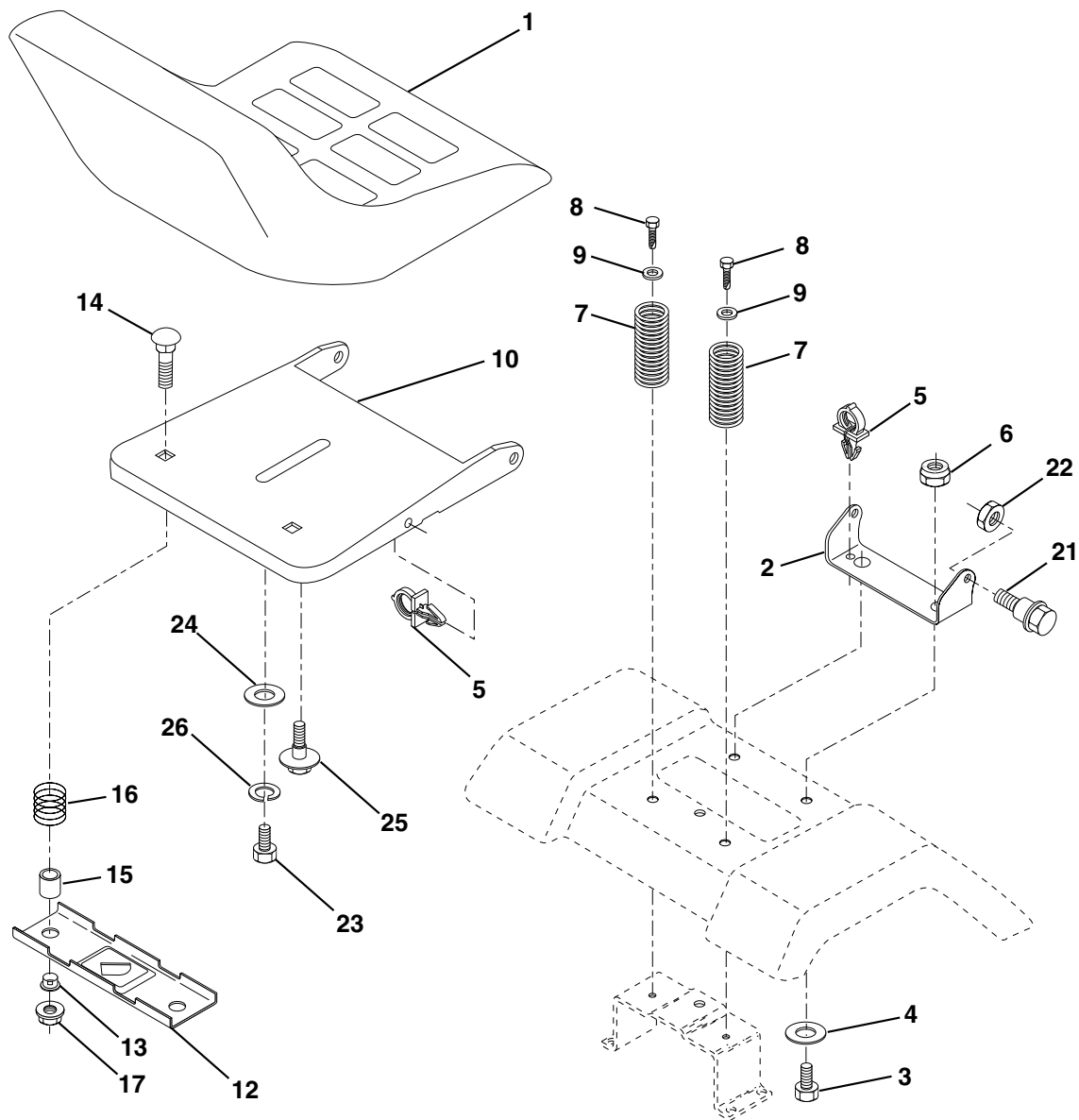

KEY NO.	PART NO.	DESCRIPTION
1	175389	Seat
2	140551	Bracket, Pivot, Seat
3	71110616	Fin Hex 3/8-16unc x 1
4	19131610	Washer 13/32 x 1 x 10 Ga.
5	145006	Clip, Push-in
6	73800600	Nut
7	124181X	Spring, Seat
8	17000616	Screw, 3/8-16 x 1.5 SMGML Tap/R
9	19131614	Washer 13/32 x 1 x 14 Ga.
10	174894	Pan, Seat
12	121246X	Bracket, Mounting, Switch, Seat
13	121248X	Bushing, Nylon

KEY NO.	PART NO.	DESCRIPTION
14	72050412	Nut, Crownlock 1/4-20 x 1-3/8
15	134300	Spacer, Split
16	121250X	Spring
17	123976X	Nut, Lock, Flange 1/4 Gr. 5
21	171852	Bolt, Shoulder 5/16-18 UNC-2A
22	73800500	Nut
23	71110814	Bolt Hex Black
24	19171912	Washer 17/32 x 1-3/16 x 12 Ga.
25	127018X	Bolt Shoulder 5/16-18 x .62
26	10040800	Washer Lock Hvy Hclc Spr 1/2

NOTE: All component dimensions given in U.S. inches
1 inch = 25.4 mm

REPAIR PARTS

TRACTOR - - MODEL NUMBER RE1138A

DECALS

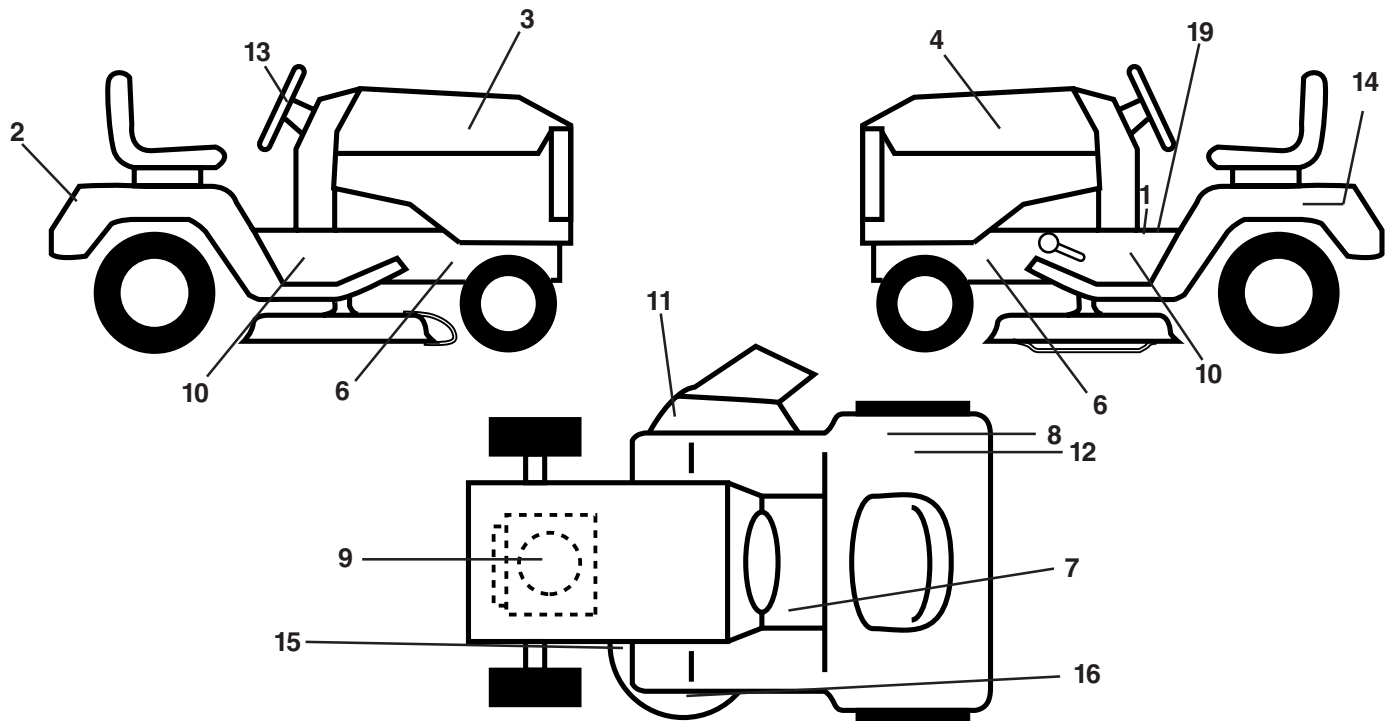

KEY NO.	PART NO.	DESCRIPTION	KEY NO.	PART NO.	DESCRIPTION
1	145498	Decal, Instruction, Operation	13	127075	Decal, Wheel Steering
2	181146	Decal, Fender	14	145005	Decal, Btry Dngr/Psn P/L Sym
3	181144	Decal, Hood R.H.	15	136832	Decal, V-Belt
4	181145	Decal Hood. L.H.	16	134999	Decal, Deck
6	159736	Decal, Chassis Hot Muffler	19	140837	Decal, Parking Brake
7	159737	Decal, Brake/Clutch Symbol LT	--	138311	Decal, Handle, Lift, Height Adjust (Lift Handle)
8	145437	Decal, Europe Stand CE	--	162598	Decal, Drawbar Load Limit
9	170843	Decal, HP Engine	--	180225	Manual, (Euro) Operator's
10	181147	Decal, Chassis	--	180226	Manual, Repair Parts
11	145494	Decal, Mower Cutoffinger Symbol			
12	126187X	Decal 100 DBA			

TIRES AND WHEELS

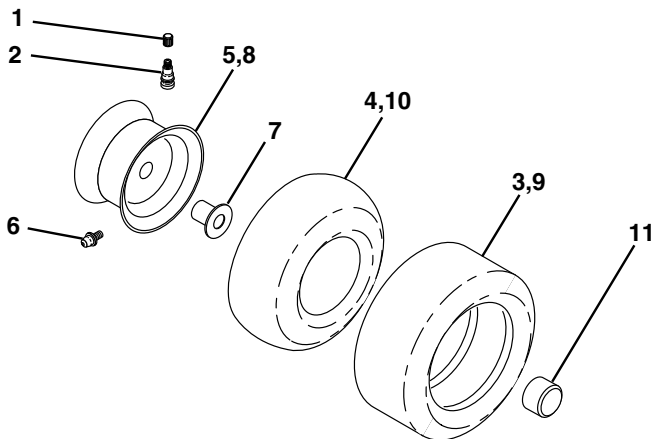

KEY NO.	PART NO.	DESCRIPTION
1	59192	Cap, Valve
2	65139	Stem, Valve
3	124157X	Tire Front
4	59904	Tube, Front (not furnished)
5	106732X427	Rim, Asm. Front
6	278H	Grease Fitting (rear tire only)
7	9040H	Bearing, Flange (front tire only)
8	106108X427	Rim, Asm. Rear
9	123969X	Tire, Rear
10	7152J	Tube, Rear (not furnished)
11	104757X428	Cap, Axle
--	144334	Sealant, Tire (10 oz. Tube)

NOTE: All component dimensions given in U.S. inches
1 inch = 25.4 mm

REPAIR PARTS

TRACTOR - - MODEL NUMBER RE1138A

STEERING WHEEL

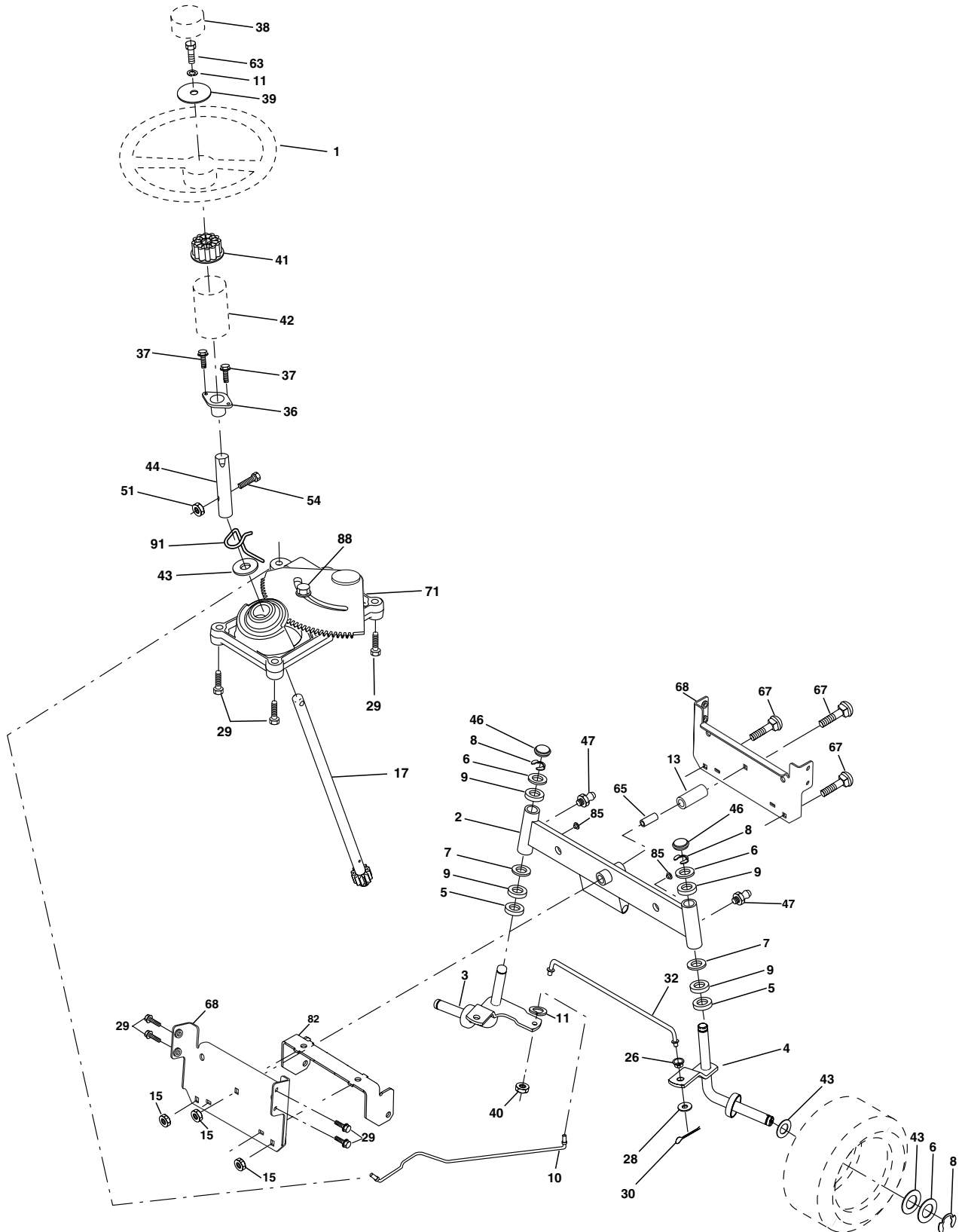

REPAIR PARTS

TRACTOR - - MODEL NUMBER RE1138A

STEERING WHEEL

KEY NO.	PART NO.	DESCRIPTION
1	133741X428	Wheel Steering
2	175131	Axle Asm Front
3	169840	Spindle Asm LH
4	169839	Spindle Asm RH
5	6266H	Bearing, Race, Thrust Hardened
6	121748X	Washer 25/32 X 1-5/8 X 16 Ga
7	19272016	Washer 27/32 X 1-1/4 X 16 Ga
8	12000029	Ring Klip
9	3366R	Bearing
10	175121	Link Drag
11	10040600	Washer Lock Hvy Hlcl Spr 3/8
13	163518	Spacer Brg. Axle Front
15	145212	Nut Hexflange Lock
17	177876	Shaft Asm
26	126847X	Bushing Link Drag Blk Lr
28	19131416	Washer 13/32 x 7/8 x 16 Ga.
29	17060612	Screw 3/8-16x3/4 SMGML Tap/R
30	76020412	Pin Cotter 1/8 x 3/4 CAD
32	130465	Rod Connecting
36	155099	Bushing Steering
37	152927	Screw TT #10-32 X 5 x 3/8 Flange
38	133742X428	Cap Wheel Steering
39	19133812	Washer 13/32 x 2-3/8 x 12 Ga
40	7810H	Nut Lock Center 3/8-24 Unf
41	100711L	Adapter Wheel Strg
42	145054X428	Boot Steering
43	121749X	Washer 25/32 X 1 1/4 X 16 Ga
44	153720	Extension Steering
46	121232X	Cap Spindle
47	6855M	Fitting Grease
51	73800500	Nut Lock Hex W/Ins. 5/16-18 Unc P
54	74780520	Bolt Fin Hex 5/16-18 Unc 6 x 1-1/4
63	74780616	Bolt Fin Hex 3/8-16unc x 1 Gr. 5
65	160367	Spacer Brace Axle
67	72140618	Bolt RDHD SQ 3/8-16UNC x 2-1/4
68	169827	Brace Axle
71	175146	Steering Asm
82	169835	Bracket Susp. Chassis Front
85	133835	Fastener Christmas Tree
88	175118	Bolt Shoulder 7/16-20unc
91	175553	Clip Steering

NOTE: All component dimensions given in U.S. inches
1 inch = 25.4 mm

REPAIR PARTS

TRACTOR - - MODEL NUMBER RE1138A

ENGINE

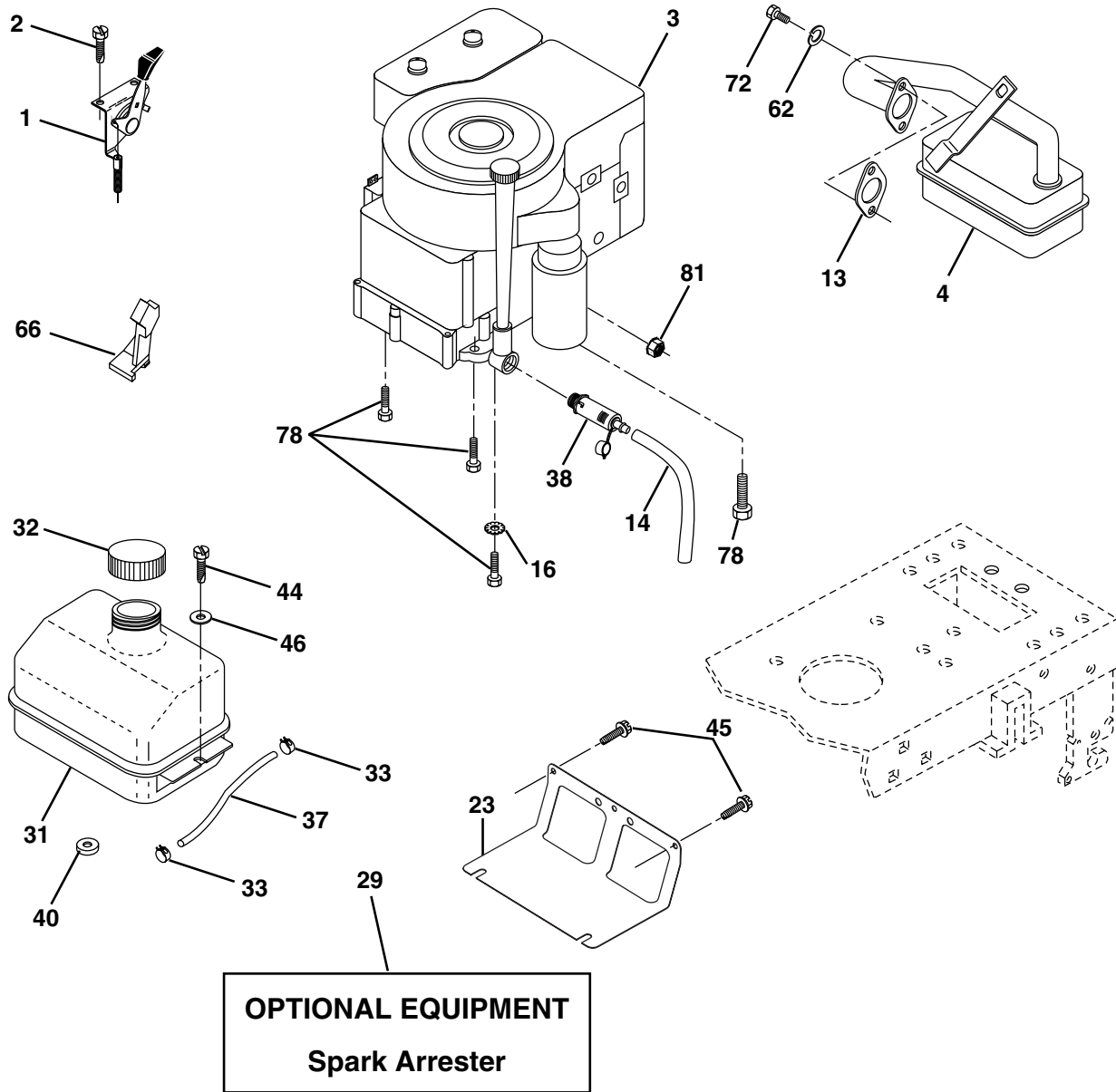

OPTIONAL EQUIPMENT
Spark Arrester

KEY NO.	PART NO.	DESCRIPTION	KEY NO.	PART NO.	DESCRIPTION
1	170865	Control Th/ch	38	148315	Plug Easy Oil Drain
2	17720408	Screw Hex Thd Cut 1/4-20 x 1/2	40	124028X	Bushing Snap Nyl Blk Fuel Line
3	-----	Engine, Briggs & Stratton Model 289707 (Order parts from engine manufacturer)	44	17670412	Screw Hexwsh Thdrol 1/4-20x3/4
4	137348	Muffler Exhaust	45	17000612	Screw Hex Wsh Thdrol 3/8-16
13	165291	Gasket Muffler	46	19091416	Washer 9/32 X 7/8 X 16 Ga
14	148456	Tube Drain Oil Easy	62	10040500	Washer 5/16
16	11050600	Washer Lock Ext Tooth 3/8	66	127951	Stop Throttle
23	169837	Shield BRN/DBR Guard	72	71070512	Screw Hex Hd Cap 5/16-18 x 3/4
29	137180	Kit Spark Arrestor (Flat Scrn)	78	17060620	Screw 3/8-16x1-1/4 SMGML Tap/R
31	109202X	Tank Fuel Front	81	73510400	Nut Keps Hex 1/4-20 UNC
32	140527	Cap Asm Fuel			
33	123487X	Clamp Hose Blk			
37	137040	Line Fuel			

NOTE: All component dimensions given in U.S. inches.
1 inch = 25.4 mm.

REPAIR PARTS

TRACTOR - - MODEL NUMBER RE1138A

MOWER LIFT

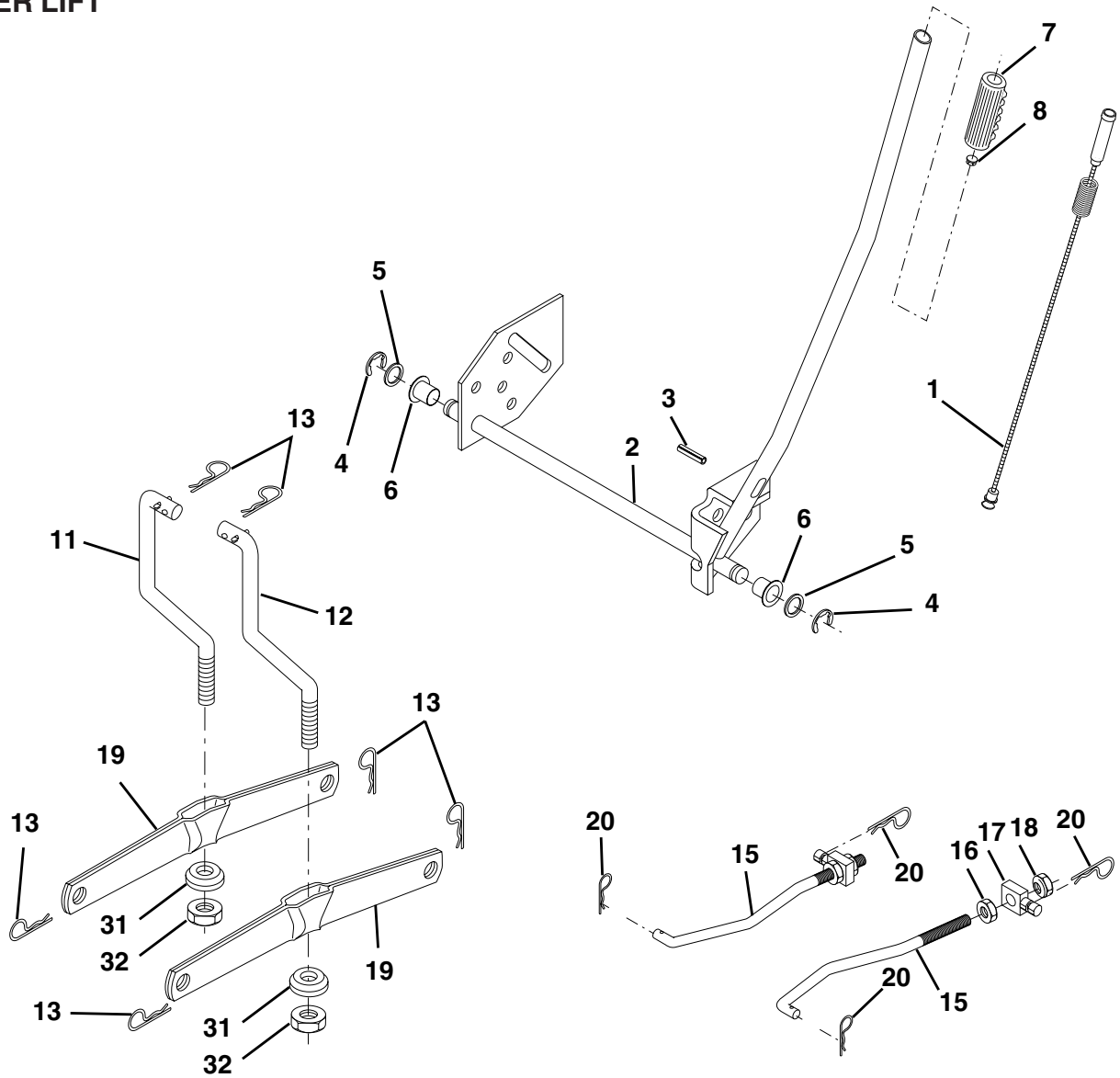

KEY NO.	PART NO.	DESCRIPTION
1	159460	Wire Asm. Inner/Sprg w/Plunger
2	159471	Shaft, Asm., Lift R/H
3	105767X	Pin, Groove
4	12000002	Ring, E #5133-62
5	19211621	Washer 21/32 x 1 x 21 Ga.
6	120183X	Bearing, Nylon
7	109413X	Grip Handle Bicycle Matte Blk
8	124526X	Button, Plunger
11	139865	Link, Lift, Lh
12	139866	Link, Lift, Rh
13	4939M	Spring, Retainer

KEY NO.	PART NO.	DESCRIPTION
15	173288	Link, Front
16	73350800	Nut, Jam, Hex 1/2-13 Unc
17	175689	Trunnion
18	73800800	Nut, Lock w/Wsh 1/2-13 Unc
19	139868	Arm, Suspension, Rear
20	163552	Spring, Retainer Zinc
31	169865	Bearing, Pvt Lft
32	73540600	Nut Crownlock 3/8-24

NOTE: All component dimensions given in U.S. inches
1 inch = 25.4 mm

REPAIR PARTS

TRACTOR - - MODEL NUMBER RE1138A

MOWER DECK

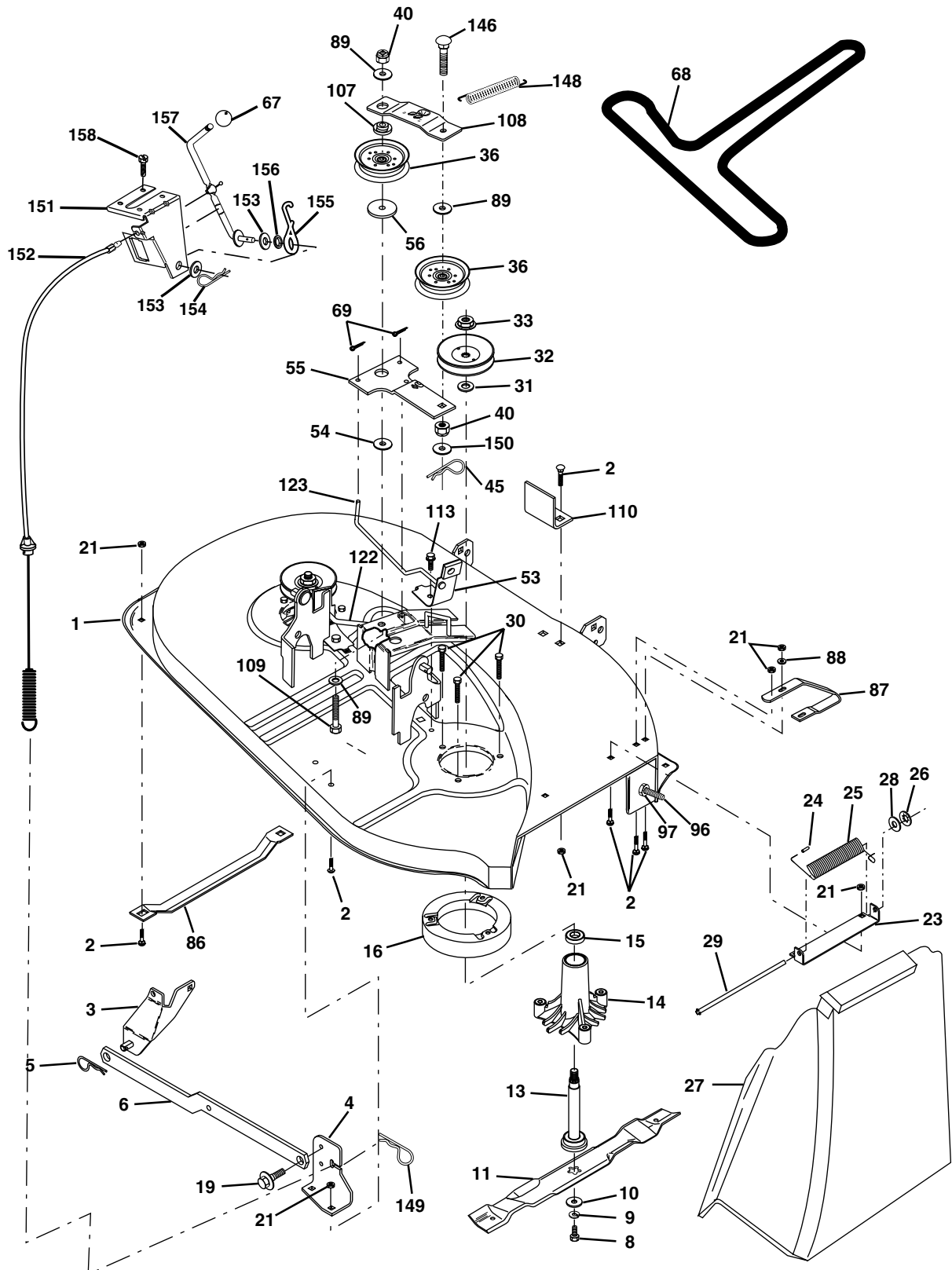

REPAIR PARTS

TRACTOR - - MODEL NUMBER RE1138A

MOWER DECK

KEY NO.	PART NO.	DESCRIPTION	KEY NO.	PART NO.	DESCRIPTION
1	170280	Deck Asm Weldment	68	144200	V-Belt, Mower
2	72140506	Bolt	69	76020312	Pin, Cotter 3/32 x 3/4
3	138017	Asm., Bar, Anti-Sway	86	7631J	Runner, LH
4	169970	Bracket Sway Bar Deck 38/42"	87	128772	Runner, RH
5	4939M	Spring, Retainer	88	19111216	Washer 11/32 x 3/4 x 16 Ga.
6	178024	Bar Sway Deck	89	19131612	Washer 13/32 x 1 x 12 Ga.
8	850857	Bolt 3/8-24 x 1.25 Gr. 8	96	74930620	Bolt 3/8-16 x 1-1/4
9	10030600	Washer, Lock	97	73930600	Nut Centerlock 3/8-16
10	140296	Washer, Hardened	107	133502	Spacer, Retainer
11	138497	Blade, Mower, Hi Lift	108	133503	Stiffener, Idler Arm
13	137645	Asm., Shaft, Mandrel, Vented	109	74760640	Bolt, hex Head 3/8-16 x 2-1/2
14	128774	Housing, Mandrel, Vented	110	142587	Upstop Deck Front 38"
15	110485X	Bearing, Ball, Mandrel	113	17060512	Screw, 5/16-18 x 3/4
16	174493	Stripper, Mower	122	131289	Rod, Brake, LH
19	132827	Bolt, Shoulder	123	169971	Rod, Brake, RH
21	73680500	Nut, Crownlock 5/16 - 18 UNC	146	165891	Bolt Carriage Idler
23	137607	Bracket, Deflector	148	169022	Spring Return Idler
24	105304X	Cap, Sleeve	149	165898	Retainer Spring Yellow Zinc
25	123713X	Spring, Torsion, Deflector	150	19091216	Washer 9/32 x 3/4 x 16 Ga.
26	110452X	Washer, Lock	151	169670	Bracket Clutch Cable
27	106736X428	Deflector, Shield	152	172758	Clutch Cable 38"/42"
28	19111016	Washer 11/32 x 5/8 x 16 Ga.	153	169674	Washer Flat 3/8" Type B
29	106735X	Rod, Hinge	154	169675	Spring Retainer
30	173984	Screw Hex Thdrol	155	169671	Spring Retention Lvr Cltch Cab
31	129963	Washer, Spacer	156	169672	Spacer Clutch Cable 3/8"
32	153532	Pulley, Mandrel	157	169669	Rod Clutch Cable 3/8"
33	178342	Nut Lock	158	17720408	Screw Hex Thd Cut 1/4-20 x 1/2
36	131494	Pulley, Idler, Flat	--	130794	Mandrel Assembly (includes Housing, Shaft and Shaft Hardware Only - Pulley Not Included)
40	73680600	Nut, Crownlock 3/8 - 16 UNC	--	180874	Replacement Mower, Complete
45	4497H	Retainer Spring 1: Zinc/Cad			
53	130840	Brake Assembly			
54	133943	Washer, Hardened			
55	133840	Arm, Idler Assembly			
56	165723	Spacer, Retainer			
67	106932X	Knob Rd 3/8-16 Plstc Thds Blk			

NOTE: All component dimensions given in U.S. inches
1 inch = 25.4 mm



TECUMSEH

SERVICE POLICY WARRANTY



TECUMSEH

Issued January 1980
Revised January 1991

LIMITED WARRANTIES FOR NEW PEERLESS GEAR POWER TRAIN COMPONENTS

A. Products Warranted

Peerless Gear and Machine Division of Tecumseh Products Company ("Tecumseh"), subject to the limitations contained below, will, at its option, repair or replace, without charge for parts or labor only, any part of a new Power Train Component (which as used herein means and includes the transaxle, gear box, transmission, differential and right angle drives, and any part of the Power Train Component), EXCEPT any new Power Train Component incorporated in equipment used for commercial or rental purposes, which is found upon examination by any Tecumseh Authorized Service Outlet or by Tecumseh's factory in Grafton, Wisconsin, to be DEFECTIVE IN MATERIAL AND/OR WORKMANSHIP if received by Tecumseh or a Tecumseh Authorized Service Outlet for such examination within TWO YEARS from the date of sale to the original consumer purchaser of Peerless Series 820, 900, 910, 915, 920, 930 transaxles and Series 1100 angle drive and ONE YEAR for all other Peerless products. New Power Train Components incorporated in equipment used for commercial purposes are warranted in the same manner and to the same extent EXCEPT such Power Train Components are warranted for NINETY (90) DAYS ONLY, and must be received by Tecumseh or by a Tecumseh Authorized Service Outlet for such examination within 90 days from the date of sale to the original purchaser. New Power Train Components Incorporated in equipment used for rental purposes are warranted in the same manner and to the same extent EXCEPT such Power Train Components are warranted for THIRTY (30) DAYS ONLY, and must be received by Tecumseh or a Tecumseh Authorized Service Outlet within 30 days from the date of sale to the original purchaser.

B. Products And Items Not Warranted

1. Alterations or Modifications of Power Train Components.
 2. Accidents, Normal Maintenance, Failure to follow the Original Equipment Manufacturer's Manual.
- This warranty covers only parts of new Power Train Components which are found upon examination to be defective in material or workmanship as delivered to the original purchaser. This warranty does not cover defects caused by depreciation or damage caused by normal wear, accidents, improper maintenance, improper use or abuse of the product, failure to follow the instructions contained in an Instruction Manual for the operation of the Power Train Component and parts. The cost of normal maintenance and replacement of service items which are not defective shall be paid for by the original purchaser.

C. Securing Warranty Service

Warranty service can be arranged for by contacting either a Tecumseh Authorized Service Outlet (any Tecumseh Registered Service Dealer, Tecumseh Authorized Service Distributor, or Tecumseh Central Warehouse Distributor) or by contacting Tecumseh, c/o Service Manager, Engine and Transmission Group Service Division, 900 North Street, Grafton, Wisconsin 53024. Warranty service can only be performed by a Tecumseh Authorized Service Outlet or by Tecumseh at its factory in Grafton, Wisconsin. At the time of requesting warranty service, evidence must be presented of the date of sale to the original purchaser. The purchaser shall pay any charges for making service calls and/or for transporting the product to and from the place where the inspection and/or warranty work is performed. The purchaser shall be responsible for any damage or loss incurred in connection with the transportation of Power Train Components and/or part(s) of the Power Train Components submitted for inspection and/or warranty work.

D. Limitation of Damages and Implied Warranties

The foregoing EXPRESSED WARRANTY IS IN LIEU OF ALL OTHER EXPRESS WARRANTIES. Neither Tecumseh nor any of its affiliates makes any warranties, representations or promises, written or oral, as to the quality of the Power Train Component or any of its parts, other than as set forth herein.

ANY IMPLIED WARRANTY OF MERCHANTABILITY OR FITNESS FOR A PARTICULAR PURPOSE, TO THE EXTENT THAT EITHER MAY APPLY TO ANY PART(S) OF POWER TRAIN COMPONENTS, SHALL BE LIMITED IN DURATION TO THE PERIODS OF THE EXPRESSED WARRANTIES DEFINED IN PARAGRAPH A HEREOF. IN NO EVENT WILL TECUMSEH BE LIABLE FOR ANY INCIDENTAL, CONSEQUENTIAL OR SPECIAL DAMAGES AND/OR EXPENSES. Some states do not allow limitations on how long an implied warranty lasts or the exclusion or limitation of incidental or consequential damages, so the above limitation(s) or exclusion(s) may not apply to you. This warranty gives you specific legal rights and you may also have other legal rights which vary from state to state.

E. No Dealer Warranty

Tecumseh neither assumes nor authorizes any other person, natural or corporate, to assume for Tecumseh any other obligations or liabilities in connection with or with respect to any part(s) of a Power Train Component. The seller or dealer of part(s) of a Power Train Component has no authority, whatsoever, to make any representations or promises on behalf of Tecumseh or to modify the terms or limitations of Tecumseh's warranty in any way.