

**REPAIR PARTS MANUAL**  
**MODEL NO. RE1196 (RE11T96A)**  
**Lawn Tractor**

---

**Rally**

00137

# HOW TO USE THIS MANUAL

This manual is designed to provide the customer with a means to identify the parts on his/her tractor when ordering repair parts. The illustrations may or may not represent the actual assemblies; therefore, it is not recommended to use this manual as a guide to assemble or disassemble the tractor. Some hardware and parts are drawn larger in order to more readily identify them.

Each tractor has its own model number.

The model number for your tractor can be found on the fender under the seat.

When ordering parts, always give the following information:

- Product - "Lawn Tractor"
- Model Number - "RE1196 (RE11T96A)"
- Part Number
- Part Description

## TABLE OF CONTENTS

SCHEMATIC .....	3
ELECTRICAL.....	4-5
CHASSIS AND ENCLOSURES.....	6-7
DRIVE.....	8-9
STEERING WHEEL .....	10-11
ENGINE.....	12
SEAT .....	13
DECALS.....	14
MOWER LIFT .....	15
MOWER DECK .....	16-17

# TRACTOR - - MODEL NO. RE1196 (RE11T96A), PRODUCT NO. 964 79 78-00 SCHEMATIC

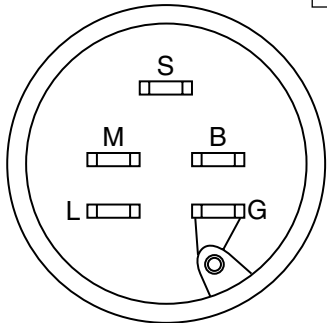
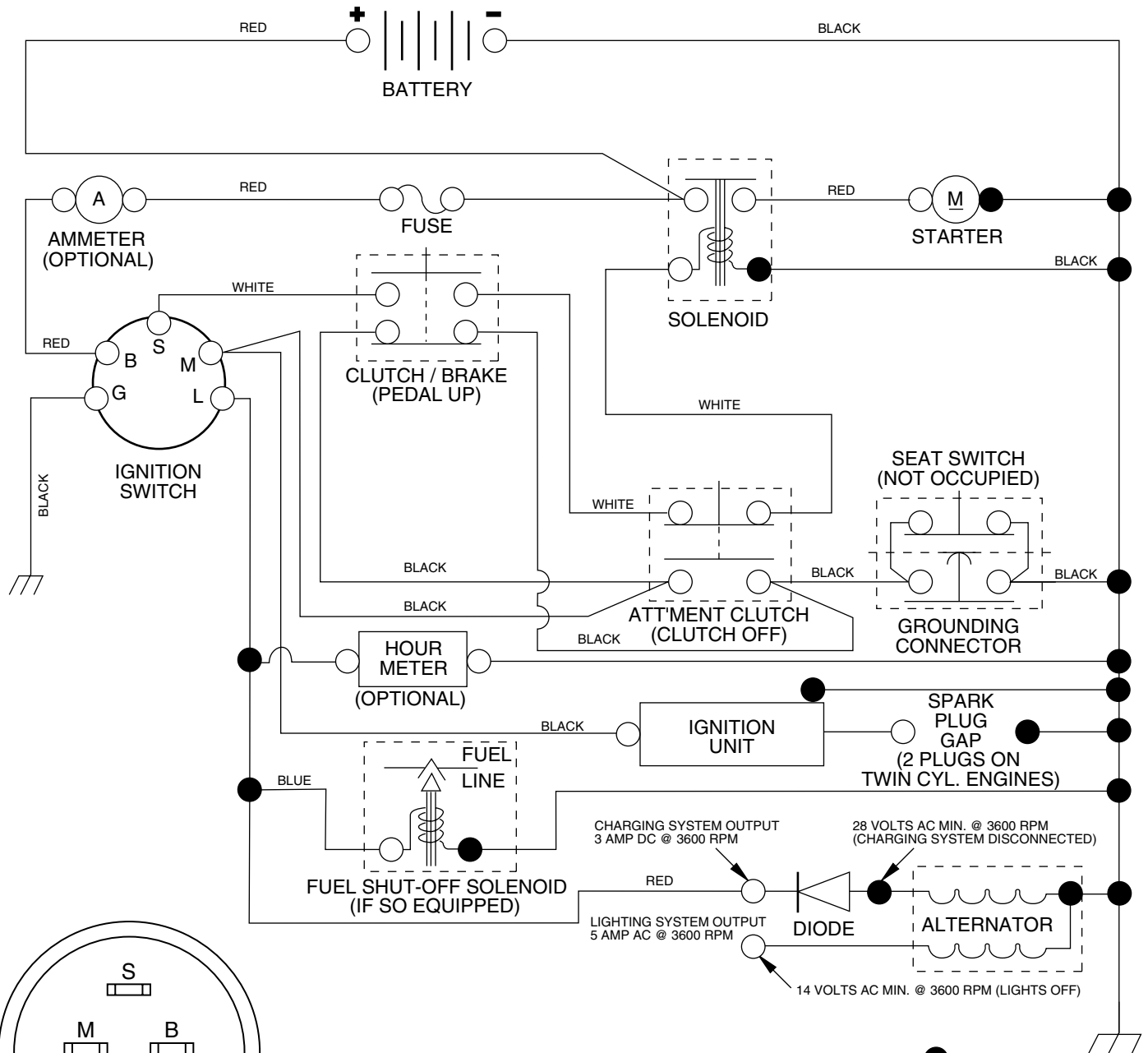

**IGNITION SWITCH**

POSITION	CIRCUIT
OFF	M + G
ON	B + L
START	B + S + L

**WIRING INSULATED CLIPS**  
**NOTE:** IF WIRING INSULATED CLIPS WERE REMOVED FOR SERVICING OF UNIT, THEY SHOULD BE REPLACED TO PROPERLY SECURE YOUR WIRING.

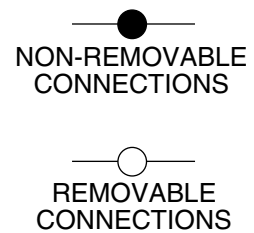

# REPAIR PARTS

TRACTOR - - MODEL NO. RE1196 (RE11T96A), PRODUCT NO. 964 79 78-00  
ELECTRICAL

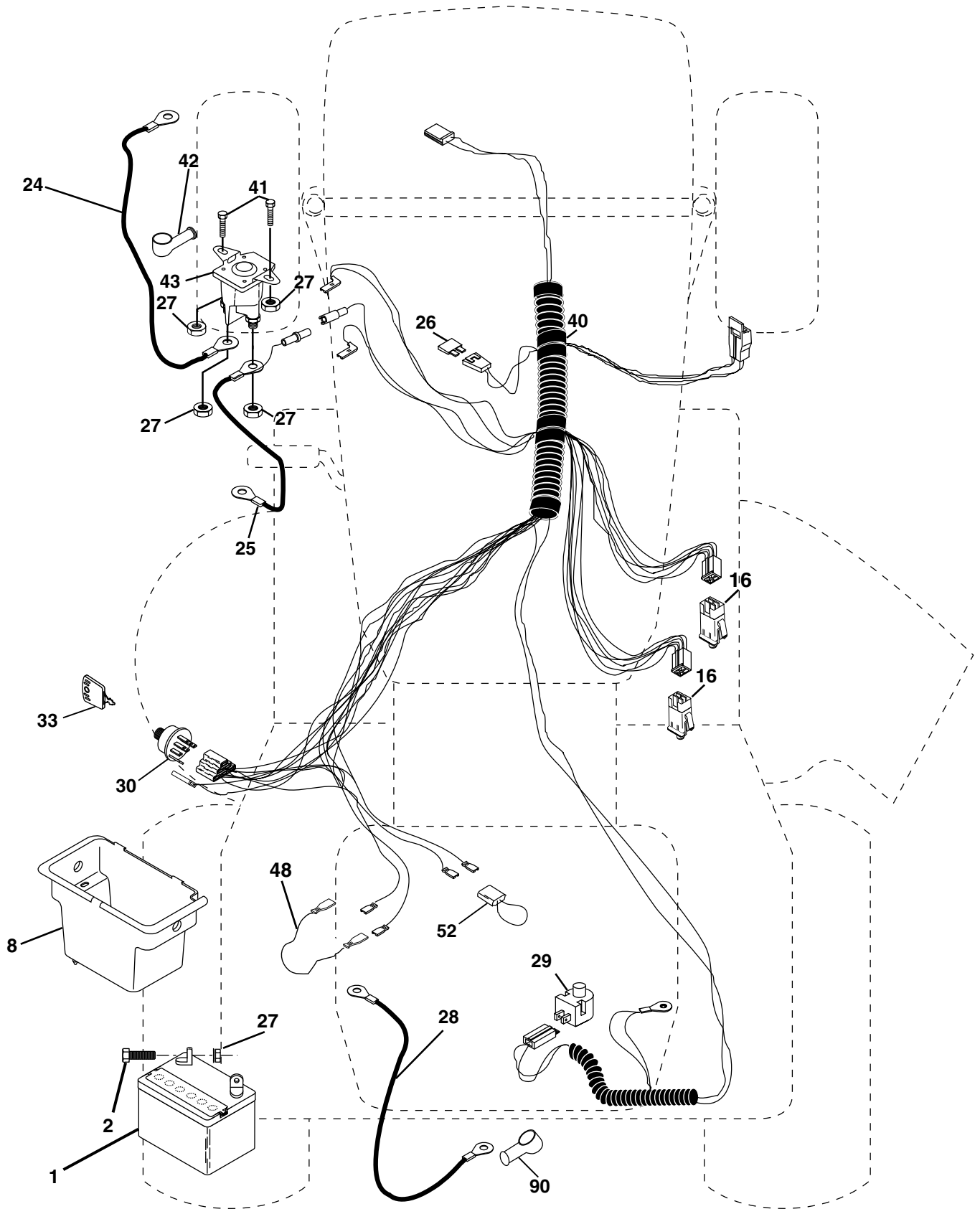

# REPAIR PARTS

TRACTOR - - MODEL NO. RE1196 (RE11T96A), PRODUCT NO. 964 79 78-00  
ELECTRICAL

KEY NO.	PART NO.	DESCRIPTION
1	532 16 34-65	Battery 12 Volt 25 Amp
2	874 76 04-12	Bolt Hex Hd 1/4-20unc X 3/4
8	532 17 66-89	Battery Box
16	532 17 61-38	Switch Interlock Push-In
24	532 10 84-23	Cable Battery 6 Ga 16"red
25	532 14 61-47	Cable Battery
26	532 17 51-58	Fuse
27	873 51 04-00	Nut Keps Hex 1/4-20 Unc
28	532 12 47-73	Cable Ground 6 Ga 12"black
29	532 12 13-05	Switch Plunger Nc Gray
30	532 17 55-67	Switch Ign
33	532 14 04-01	Key Ign
40	532 17 97-30	Harness Ign
41	871 11 04-08	Bolt Blk Fin Hex 1/4-20
42	532 13 15-63	Cover Terminal Red
43	532 17 88-61	Solenoid
48	532 14 08-44	Adapter Ammeter
52	532 14 19-40	Protection Wire Loop
90	532 18 04-49	Cover Terminal Battery

**NOTE:** All component dimensions given in U. S. inches 1 inch = 25.4 mm.

# REPAIR PARTS

TRACTOR - - MODEL NO. RE1196 (RE11T96A), PRODUCT NO. 964 79 78-00  
CHASSIS

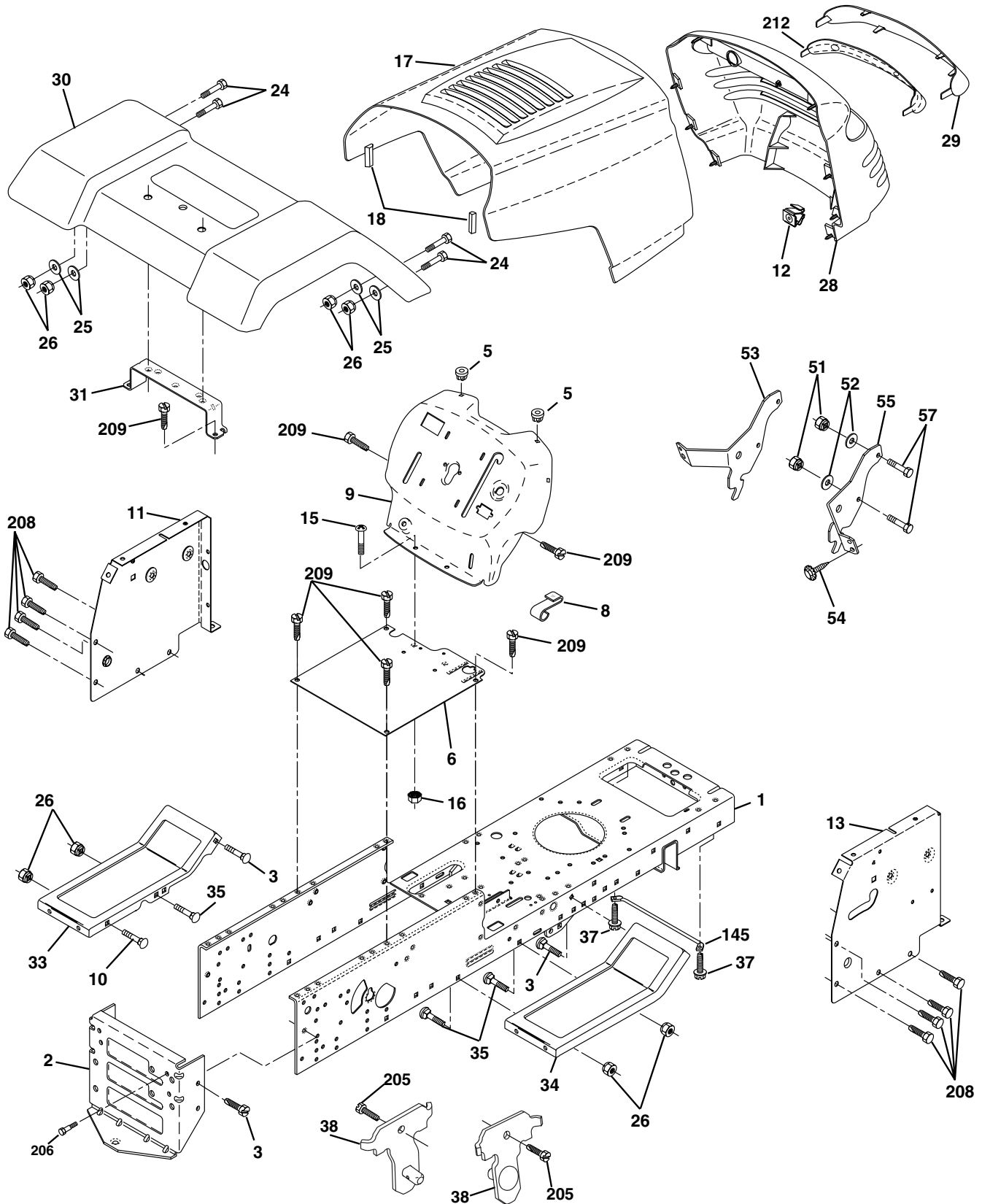

# REPAIR PARTS

TRACTOR - - MODEL NO. RE1196 (RE11T96A), PRODUCT NO. 964 79 78-00  
CHASSIS

KEY NO.	PART NO.	DESCRIPTION
1	532 17 46-20	Chassis
2	532 17 65-54	Drawbar
3	817 06 06-12	Screw 3/8-16 x 3/4
5	532 15 52-72	Bumper, Hood/Dash
6	532 18 12-71	Saddle
8	532 15 51-38	Clip Retainer Slide-On
9	532 18 54-80	Dash
10	872 14 06-08	Bolt, Carriage 3/8-16 x 1
11	532 17 49-96	Panel Dash LH
12	532 14 56-60	Clip Tinnerman Grille P.L
13	532 18 17-19	Panel Silkscr Dash RH
15	874 18 05-12	Screw Mach TRHD 5/16-18uncx3/4
16	873 51 05-00	Nut Keps 5/16-18 Unc
17	532 16 35-57	Hood
18	532 18 49-21	Bumper Hood
24	874 78 06-16	Bolt Fin Hex 3/8-16unc X 1 Gr. 5
25	819 13 13-12	Washer 13/32 X 13/16 X 12 Ga
26	873 80 06-00	Nut Lock Hex w/Ins 3/8-16 Unc
28	532 17 97-80	Grille/Lens Asm.
29	532 18 25-36	Lens Grille Private Label
30	532 18 25-35	Fender
31	532 13 66-19	Bracket Fender Repl 109873x
33	532 18 11-93	Footrest Pnt LH
34	532 18 11-94	Footrest Pnt RH
35	872 11 06-06	Bolt Rdhd Sht Sqnk 3/8-16 X3/4
37	817 49 05-08	Screw Thdrol 5/16-18 x 1/2 TYT
38	532 17 57-10	Bracket Asm. Pivot Mower Rear
51	873 80 04-00	Nut Lock W/Insert 1/4-20unc
52	819 09 14-16	Washer 9/32 x 7/8x16 Ga.
53	532 14 46-97	Bracket Grille Lh
54	532 16 14-64	Screw Hex 8-18 x 7/8
55	532 14 46-96	Bracket Grille Rh
57	874 78 04-12	Bolt Fin Hex 1/4-20 unc x .75
145	532 15 65-24	Rod Pivot Chassis/Hood
205	817 49 06-08	Screw Thdrol 3/8-16 x 1/2
206	532 17 01-65	Bolt Shoulder 5/16-18
208	817 67 06-08	Screw Thdrol 3/8-16 x 1/2
209	817 00 06-12	Screw Hex Wsh Thdrol 3/8-16
212	532 15 64-94	Insert Lens Reflect
---	532 00 54-79	Plug Button Blk 359 Dia Choke

**NOTE:** All component dimensions given in U.S. inches  
1 inch = 25.4 mm.

# REPAIR PARTS

TRACTOR - - MODEL NO. RE1196 (RE11T96A), PRODUCT NO. 964 79 78-00  
DRIVE

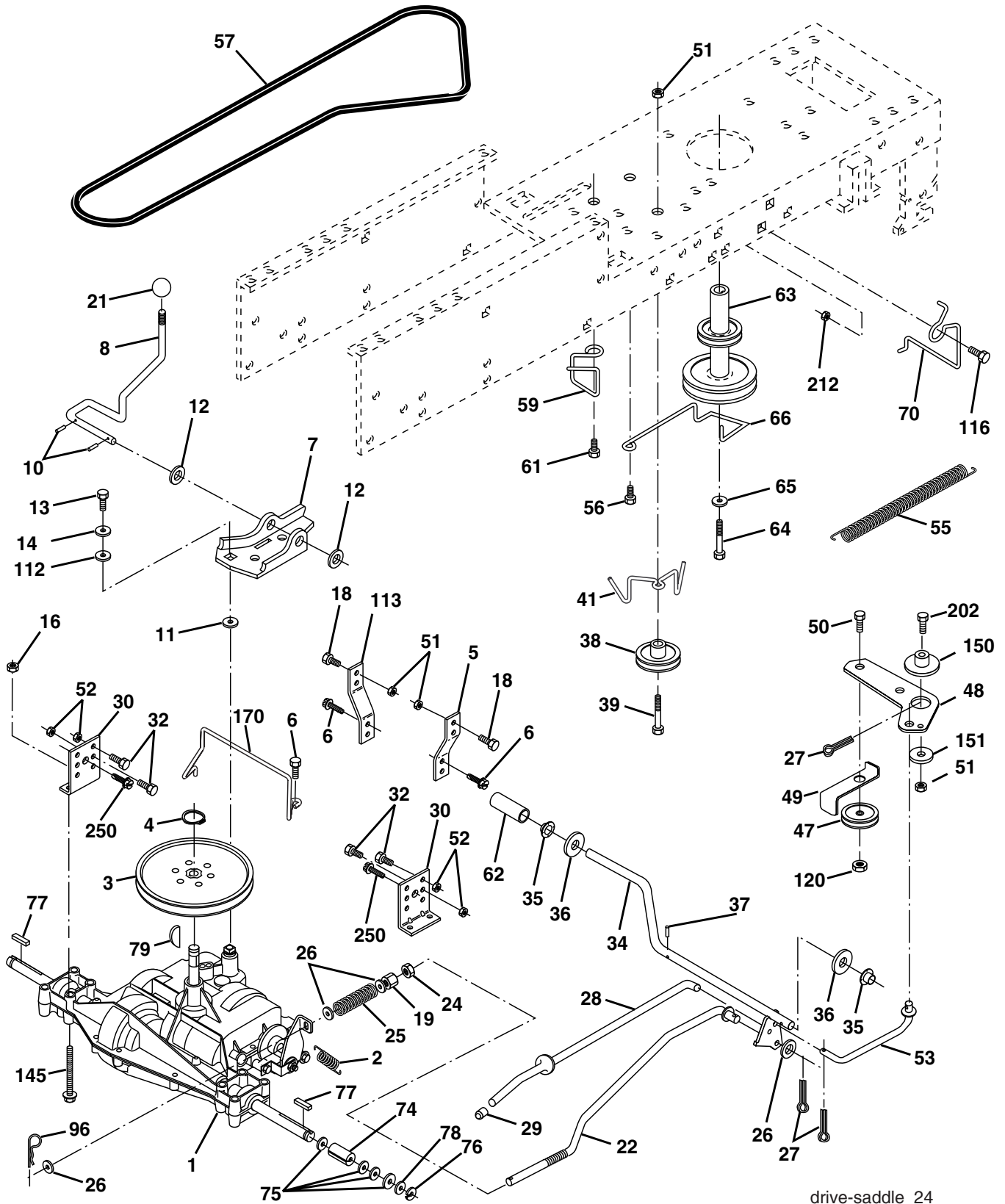

drive-saddle\_24



# REPAIR PARTS

TRACTOR - - MODEL NO. RE1196 (RE11T96A), PRODUCT NO. 964 79 78-00  
DRIVE

KEY NO.	PART NO.	DESCRIPTION	KEY NO.	PART NO.	DESCRIPTION
1	-----	Transaxle, Peerless 204-506B (Order parts from transaxle manufacturer)	48	532 15 44-07	Bellcrank Asm
2	532 14 66-82	Spring Return Brake T/a Zinc	49	532 12 32-05	Retainer Belt Style Spring
3	532 12 36-66	Pulley Transaxle 18" tires	50	872 11 06-12	Bolt Carr. Sh. 3/8-16 x 1-1/2 Gr. 5
4	812 00 00-28	Ring Retainer # 5100-62	51	873 68 06-00	Nut Crownlock 3/8-16 Unc
5	532 12 15-20	Strap Torque 30 Degrees	52	873 68 05-00	Nut Crownlock 5/16-18 Unc
6	817 06 05-12	Screw 5/16-18 x 3/4	53	532 10 57-10	Link Clutch
7	532 16 22-40	Bracket T/A Saddle Shift	55	532 10 57-09	Spring Return Clutch 6 75
8	532 13 16-79	Rod Shifter	56	817 06 06-20	Screw 3/8-16 X 1-1/4
10	876 02 04-16	Pin Cotter 1/8 x 1 Cad	57	532 13 08-01	V-Belt Ground Drive
11	532 10 57-01	Washer Plate Shf 388 Sq Hole	59	532 16 96-91	Keeper Belt Span Ctr
12	819 15 12-16	Washer 15/32 x 3/4 x 16	61	817 12 06-14	Screw 3/8-16 x .875
13	874 55 04-12	Bolt 1/4-28 Unf Gr 8 W/Patch	62	532 12 48-72	Cover Pedal Blk Round
14	810 04 04-00	Washer Lock Hvy Helical 1/4	63	532 18 02-19	Engine Pulley
16	873 80 05-00	Nut Lock w/Ins 5/16-18 Unc	64	871 17 07-64	Bolt Hex
18	874 78 06-16	Bolt Fin Hex 3/8-16 UNC x 1 Gr. 5	65	810 04 07-00	Washer Lock Hvy Hlcl Spr 7/16
19	873 80 06-00	Nut Lock 3/8-16 Unc	66	532 15 47-78	Keeper Belt Engine Foolproof
21	532 10 69-33	Knob	70	532 18 02-18	Guide Belt Mower Drive RH
22	532 13 08-04	Rod Brake Blk Zinc 26 840	74	532 13 70-57	Spacer Axle
24	873 35 06-00	Nut Hex Jam 3/8-16 Unc	75	532 12 17-49	Washer 25/32 X 1 1/4 X 16 Ga
25	532 10 68-88	Spring Rod Brake 2 00 Zinc	76	812 00 00-01	E-ring #5133-75
26	819 13 13-16	Washer 13/32 X 13/16 X 16 Ga	77	532 12 35-83	Key Square 2 0 X 1845/ 1865
27	876 02 04-12	Pin Cotter 1/8 X 3/4 Cad	78	532 12 17-48	Washer 25/32 X 1-5/8 X 16 Ga
28	532 17 57-65	Rod Brake Parking	79	532 12 50-96	Key Woodruff
29	532 07 16-73	Cap Brake Parking	96	532 12 47-88	Retainer Spring 1"
30	532 17 49-73	Bracket Mtg Transaxle	112	819 09 12-10	Washer 9/32 x 3/4 x 10 Ga.
32	874 76 05-12	Bolt Hex Hd 5/16-18unc x 3/4	113	532 12 72-85	Strap Torque Lh
34	532 17 55-78	Shaft Asm Pedal Foot	116	872 14 06-08	Bolt Rdhd Sq Neck 3/8-16 x 1.00
35	532 12 01-83	Bearing Nylon Blk 629 Id	120	873 90 06-00	Nut Lock Flg 3/8-16
36	819 21 16-16	Washer 21/32 X 1 X 16 Ga	145	874 49 05-40	Bolt Hex 5/16-18 Gr. 5
37	532 12 49-63	Pin Roll 3/16 X 1"	150	532 17 54-56	Spacer Retainer
38	532 17 91-14	Pulley Idler Composite	151	819 13 32-10	Washer 13/32 x 2 x 10
39	874 76 06-48	Bolt Fin Hex 3/8-16unc X 3	170	532 17 83-94	Keeper Belt T/A
41	532 17 55-56	Keeper Belt Retainer Idler	202	872 11 06-14	Bolt, Carriage 3/8 - 16 x 1-3/4
47	532 12 77-83	Pulley Idler V Groove Plastic	212	532 14 52-12	Nut Flange Hex Lock

**NOTE:** All component dimensions given in U.S. inches  
1 inch = 25.4 mm

# REPAIR PARTS

TRACTOR - - MODEL NO. RE1196 (RE11T96A), PRODUCT NO. 964 79 78-00  
STEERING

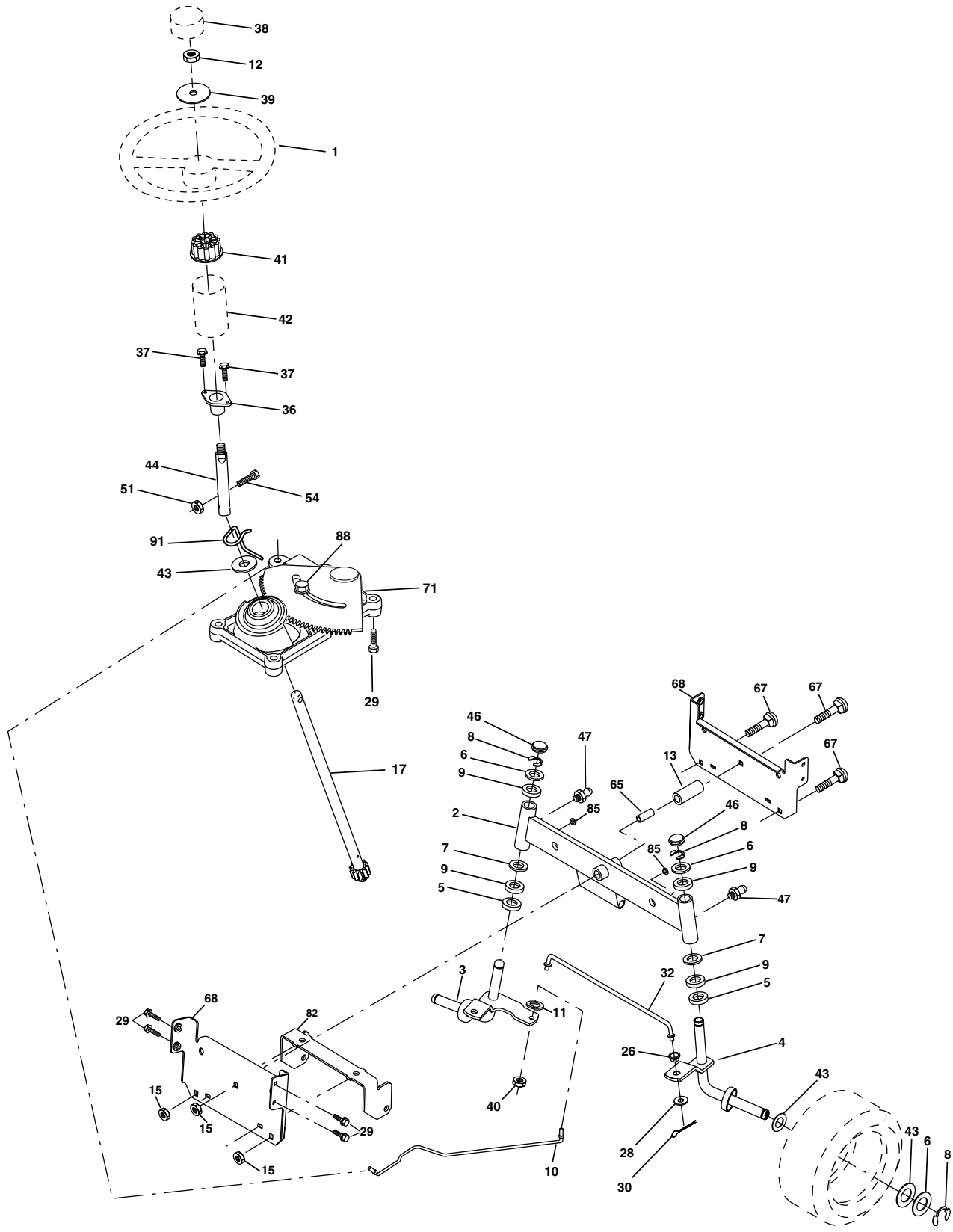

# REPAIR PARTS

TRACTOR - - MODEL NO. RE1196 (RE11T96A), PRODUCT NO. 964 79 78-00  
STEERING

KEY NO.	PART NO.	DESCRIPTION
1	532 17 71-82	Wheel Steering
2	532 17 51-31	Axle Asm
3	532 16 98-40	Spindle Asm LH
4	532 16 98-39	Spindle Asm RH
5	532 12 49-31	Bearing Race Thrust Harden
6	532 12 17-48	Washer 25/32 X 1-5/8 X 16 Ga
7	819 27 20-16	Washer 27/32 X 1-1/4 X 16 Ga
8	812 00 00-29	Ring Klip #t5304-75
9	532 12 49-37	Bearing Col Strg Blk
10	532 17 51-21	Link Drag
11	810 04 06-00	Washer Lock Hvy Hlcl Spr 3/8
12	873 94 08-00	Nut Hex Jam Toplock 1/2-20
13	532 13 65-18	Spacer earing Axle Front
15	532 14 52-12	Hexflange Lock
17	532 18 06-41	Shaft Asm Strg
26	532 12 68-47	Bushing Link Drag Blk LR
28	819 13 14-16	Washer 13/32 X 7/8 X 16 Ga
29	817 06 06-12	Screw 3/8-16 x 3/4
30	876 02 04-12	Pin Cotter 1/8 X 3/4 Cad
32	532 13 04-65	Rod Tie Wire Form 19 75 Mech
36	532 15 50-99	Bushing Strg 5/8 Id Dash
37	532 15 29-27	Screw
38	532 17 71-83	Cap Wheel Steer
39	819 18 38-12	Washer 9/16ID x 2-3/8OD 12 Ga.
40	532 12 47-01	Nut Lock Center 3/8-24un
41	532 10 07-11	Adaptor Wheel Strg
42	532 16 96-33	Boot Steering
43	532 12 17-49	Washer 25/32 X 1 1/4 X 16 Ga
44	532 18 06-40	Extension Steering
46	532 12 12-32	Cap Spindle Fr Top Blk
47	532 18 32-26	Fitting Grease
51	873 54 04-00	Nut Crownlock 1/4-28
54	871 13 04-20	Bolt Hex 1/4-28unf x 1-1/4 Gr. 8
65	532 16 03-67	Spacer Brace Axle
67	872 14 06-18	Bolt Fin Hex 5/8-11 unc x 2-3/4
68	532 16 98-27	Brace Axle
71	532 17 51-46	Steering Asm
82	532 16 98-35	Bracket Susp Chassis Front
85	532 13 38-35	Fastener Christmas Tree
88	532 17 51-18	Bolt shoulder 7/16-20
91	532 17 55-53	Clip Steering

**NOTE:** All component dimensions given in U.S. inches  
1 inch = 25.4 mm.

# REPAIR PARTS

TRACTOR - - MODEL NO. RE1196 (RE11T96A), PRODUCT NO. 964 79 78-00  
ENGINE

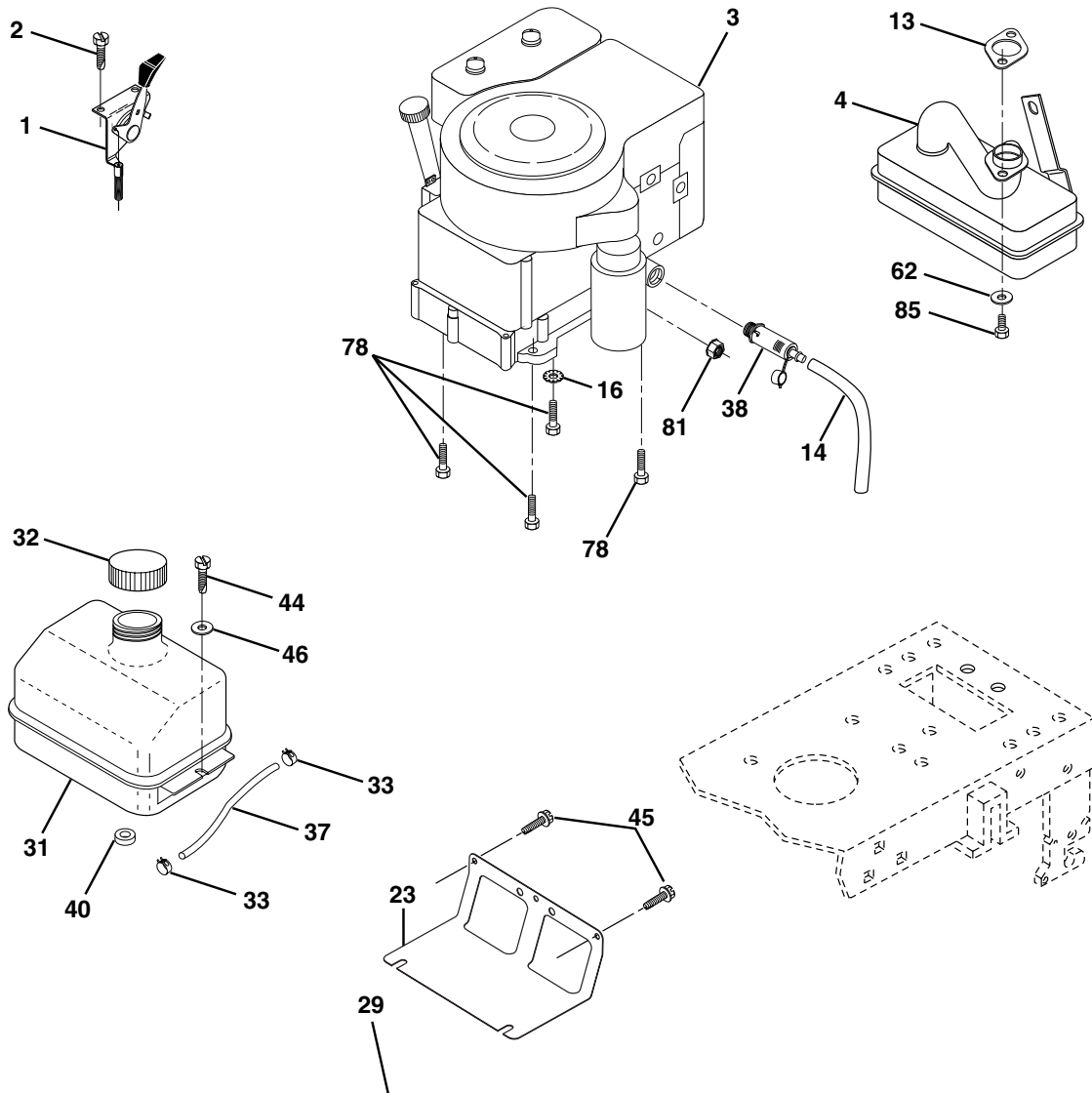

**OPTIONAL EQUIPMENT**  
**Spark Arrester**

KEY NO.	PART NO.	DESCRIPTION	KEY NO.	PART NO.	DESCRIPTION
1	532 17 08-64	Control Th/ch Flag	33	532 12 34-87	Clamp Hose
2	817 72 04-08	Screw Hex Thd Cut 1/4-20 x 1/2	37	532 13 70-40	Line Fuel 20"
3	-----	Engine, Tec OHV135 (Order parts from engine manufacturer)	38	532 18 16-54	Plug Drain Oil Easy
4	532 15 67-00	Muffler Exhaust	40	532 12 40-28	Bushing Snap NYL BLK Fuel Line
13	532 18 68-13	Gasket Muffler	44	817 67 04-12	Screw Thdrol 1/4-20 x 3/4
14	532 14 84-56	Tube Drain Oil Easy	45	817 00 06-12	Screw Hex Wsh Thdrol 3/8-16
16	811 05 06-00	Washer Lock Ext Tooth 3/8	46	819 09 14-16	Washer 9/32 X 7/8 X 16 Ga
23	532 16 98-37	Shield BRN/DBR Guard	62	810 04 05-00	Washer Lock Hvy Hlcl Spr
29	532 13 71-80	Kit Spark Arrestor (Flat Scrn)	78	817 06 06-20	Screw 3/8-16 x 1-1/4
31	532 18 49-00	Tank Fuel Front	81	873 51 04-00	Nut Keps Hex 1/4-20 Unc
32	532 14 05-27	Cap Asm Fuel	85	532 12 35-28	Bolt Hex Hd Phillips

**NOTE:** All component dimensions given in U.S. inches  
1 inch = 25.4 mm

# REPAIR PARTS

TRACTOR - - MODEL NO. RE1196 (RE11T96A), PRODUCT NO. 964 79 78-00  
SEAT

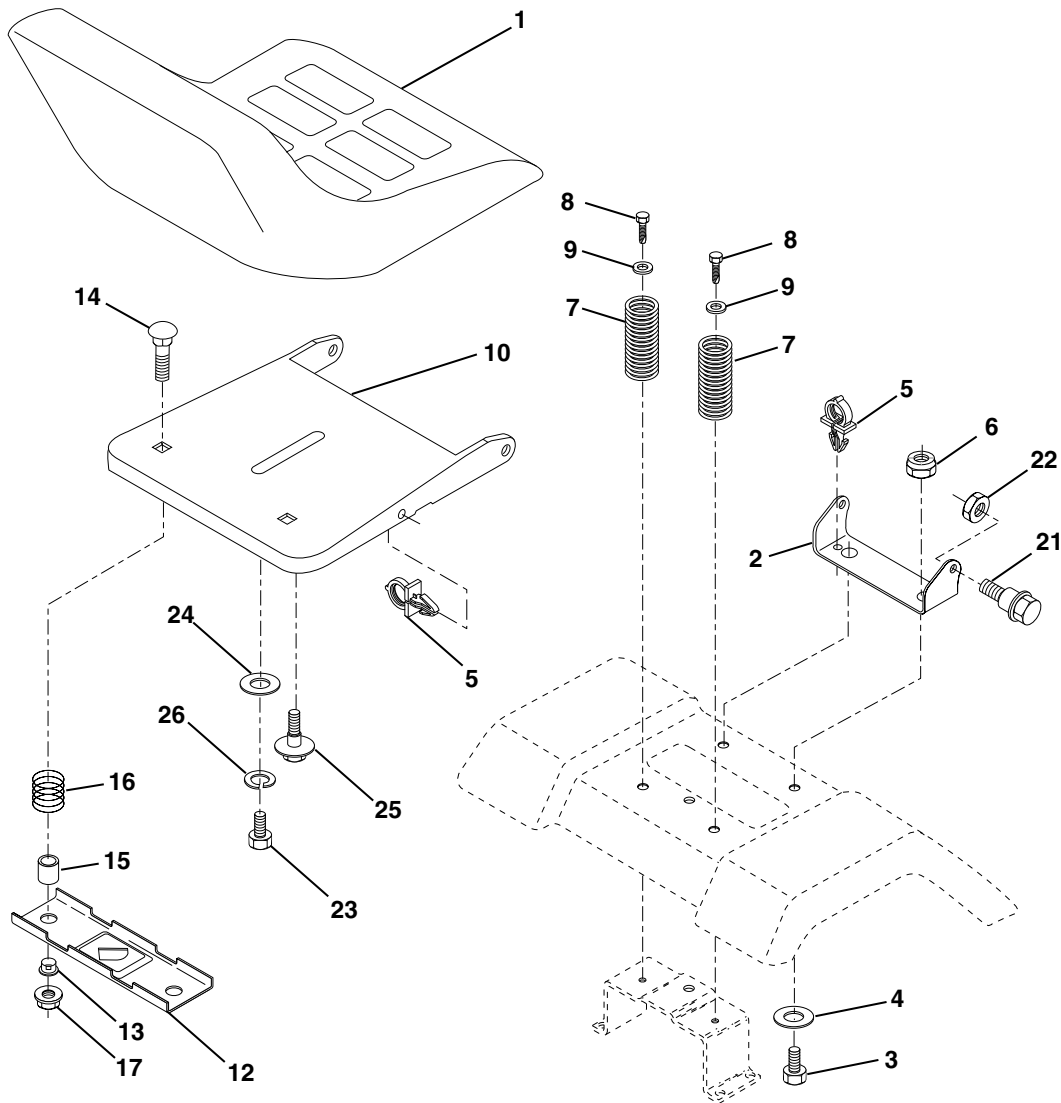

KEY NO.	PART NO.	DESCRIPTION
1	532 17 53-89	Seat
2	532 14 05-51	Bracket Seat Pivot
3	871 11 06-16	Bolt Hex 3/8 - 16 X 1
4	819 13 16-10	Washer 3/8 X 1 X 10Ga.
5	532 14 50-06	Clip Push-In Hinged
6	873 80 06-00	Nut Lock Hex w/Ins 3/8 - 16
7	532 12 41-81	Spring Seat Cprsn 2 250 Blk Zi
8	817 00 06-16	Screw 3/8-16 x 1.5
9	819 13 16-14	Washer 13/32 X 1 X 14 Ga
10	532 18 24-93	Pan Pnt Seat (Blk)
11	532 12 12-46	Bracket Pnt Mounting Switch
12	532 12 12-48	Bushing Snap Blk Nyl

KEY NO.	PART NO.	DESCRIPTION
14	872 05 04-12	Bolt Rdhd Sht Nk 1/4 - 20 X 1 -1/2
15	532 13 43-00	Spacer Split .28 X .96
16	532 12 12-50	Spring Cprsn
17	532 12 39-76	Nut Lock 1/4 Lge Flg
21	532 17 18-52	Bolt Shoulder 5/16-18 Unc-2A
22	873 80 05-00	Nut Lock Hex w/Ins 5/16 - 18
23	871 11 08-14	Bolt Hex Black
24	819 17 19-12	Washer 17/32 X 1-3/16 X 12 Ga
25	532 12 70-18	Bolt Shoulder 5/16-18 X .62
26	810 04 08-00	Washer Lock Hvy Hlcl Spr 1/2

**NOTE:** All component dimensions given in U.S. inches  
1 inch = 25.4 mm.

# REPAIR PARTS

TRACTOR - - MODEL NO. RE1196 (RE11T96A), PRODUCT NO. 964 79 78-00  
DECALS

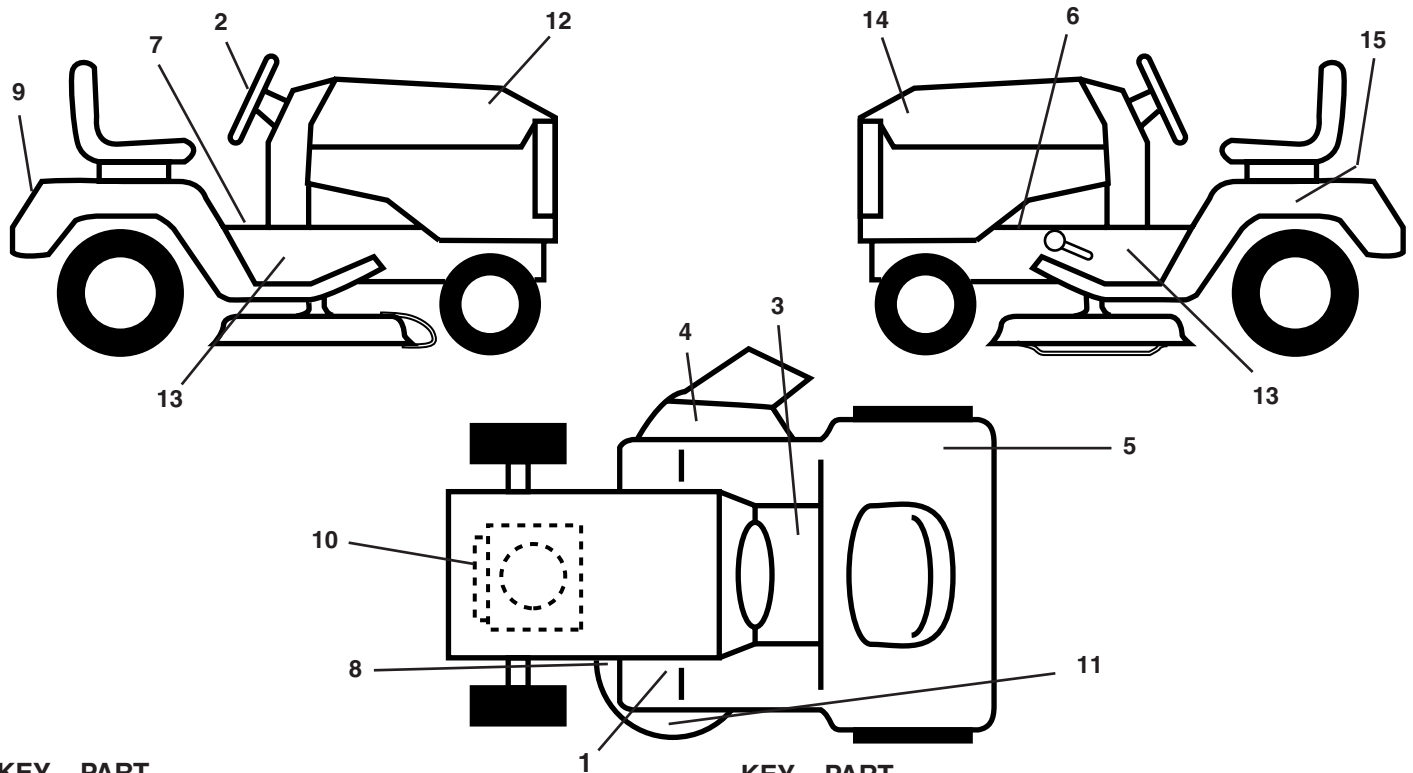

KEY NO.	PART NO.	DESCRIPTION	KEY NO.	PART NO.	DESCRIPTION
1	532 15 97-37	Decal, Clutch/Brake	11	532 13 49-99	Decal, Deck
2	532 12 70-75	Decal, Steering Wheel	12	532 18 11-44	Decal, Hood RH
3	532 14 54-98	Decal, Read Owners Manual	13	532 18 11-47	Decal, Chassis 4 Sp/38
4	532 18 21-66	Decal, Cutfinger CE 02	14	532 18 11-45	Decal, Hood LH
5	532 18 04-32	Decal, Fender 100 DB/CE	15	532 14 50-05	Decal, Caution, Battery
6	532 15 97-36	Decal, Hot Muffler	--	532 13 83-11	Decal, Handle Lft Height Adj.
7	532 14 08-37	Decal, Brake Parking Saddle	--	532 16 25-98	Decal, Draw Bar Load Limit
8	532 13 68-32	Decal, V-Belt Sch.	--	532 18 51-49	Manual, Operator's Euro
9	532 18 11-46	Decal, Fender	--	532 18 44-47	Manual, Parts
10	532 16 38-52	Decal, Tech 11.5 H.P.			

## WHEELS & TIRES

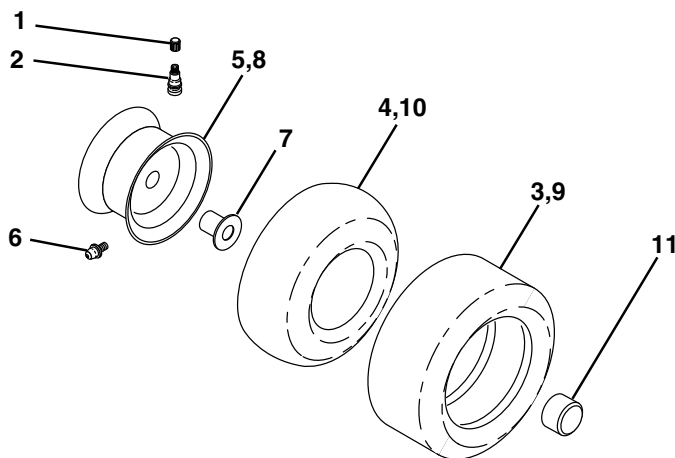

KEY NO.	PART NO.	DESCRIPTION
1	532 05 91-92	Cap, Tire valve
2	532 06 51-39	Stem, Valve
3	532 12 41-57	Tire, Front
4	532 05 99-04	Tube, Front (Service item only)
5	532 18 33-37	Rim assembly, 6" front
6	532 12 49-57	Fitting, Grease (Front wheel only)
7	532 12 49-59	Bearing, Flange (Front wheel only)
8	532 18 33-38	Rim assembly, 8" rear
9	532 12 39-69	Tire, Rear
10	532 12 49-26	Tube, Rear (Service item only)
11	532 17 50-39	Cap, Hub Axle
--	532 14 43-34	Sealant, Tire (10 oz. Tube)

**NOTE:** All component dimensions given in U.S. inches  
1 inch = 25.4 mm

# REPAIR PARTS

TRACTOR - - MODEL NO. RE1196 (RE11T96A), PRODUCT NO. 964 79 78-00  
MOWER LIFT

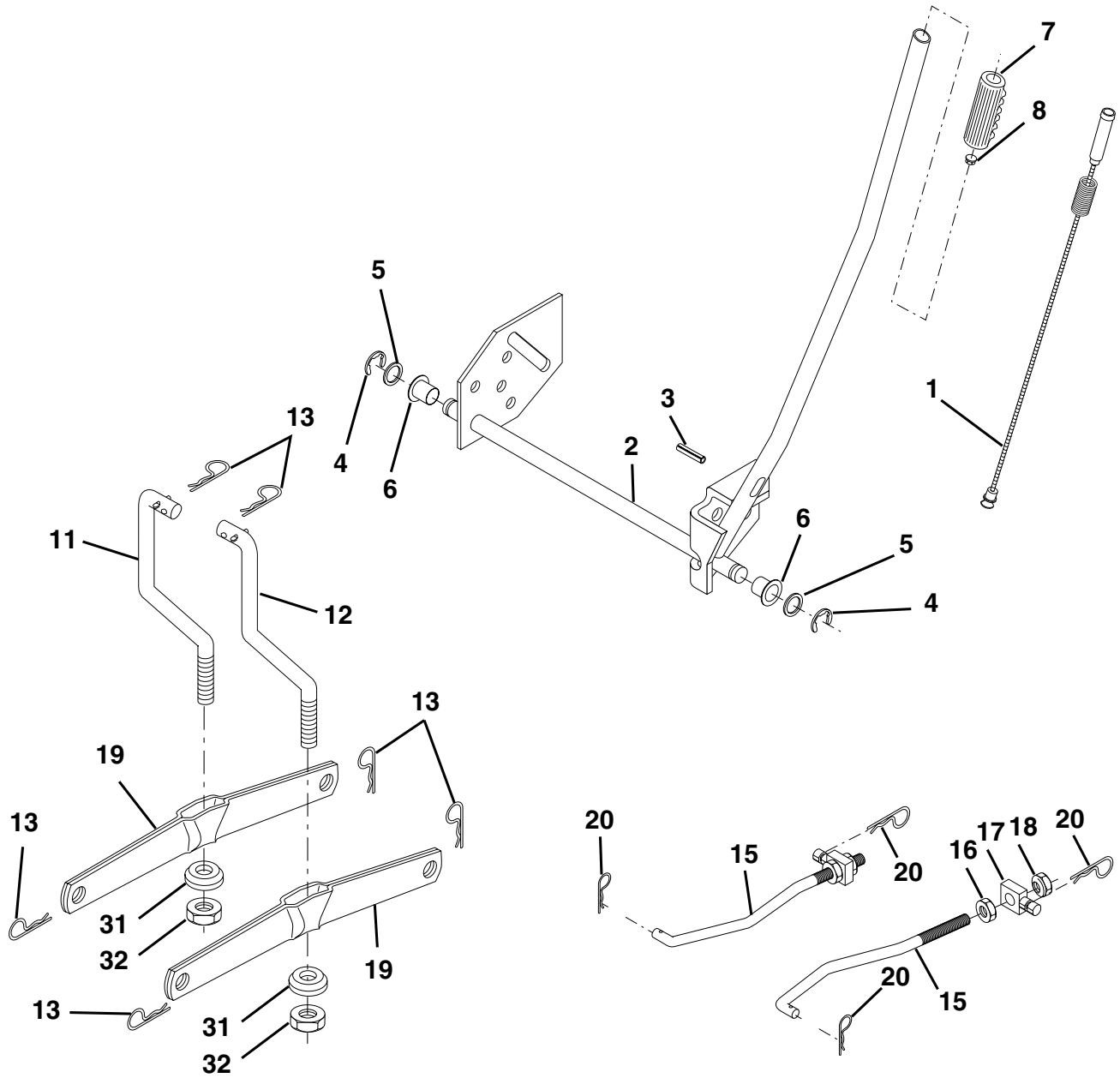

KEY NO.	PART NO.	DESCRIPTION
1	532 15 94-60	Wire Asm Inner/Sprg w/plunger
2	532 15 94-71	Shaft Asm Lift RH
3	532 10 57-67	Pin Groove 1 500 Zinc
4	812 00 00-02	E Ring #5133-62
5	819 21 16-21	Washer 21/32 X 1 X 21 Ga
6	532 12 01-83	Bearing Nylon Blk 629 Id
7	532 10 94-13	Grip Handle Bicycle Matte Blk
8	532 12 45-26	Button Plunger Black
11	532 13 98-65	Link Lift LH Fixed Length
12	532 13 98-66	Link Lift RH Fixed Length
13	532 12 46-70	Retainer Spring

KEY NO.	PART NO.	DESCRIPTION
15	532 17 32-88	Link Front
16	873 35 08-00	Nut Jam Hex 1/2-13 Unc
17	532 17 56-89	Trunnion
18	873 80 08-00	Nut Lockw/Wsh 1/2-13 Unc
19	532 13 98-68	Arm Suspension Rear
20	532 16 35-52	Retainer, Spring
31	532 16 98-65	Bearing Pvt Lift
32	873 54 06-00	Nut Crownlock 3/8-24

**NOTE:** All component dimensions given in U.S. inches  
1 inch = 25.4 mm.

# REPAIR PARTS

TRACTOR - - MODEL NO. RE1196 (RE11T96A), PRODUCT NO. 964 79 78-00  
MOWER DECK

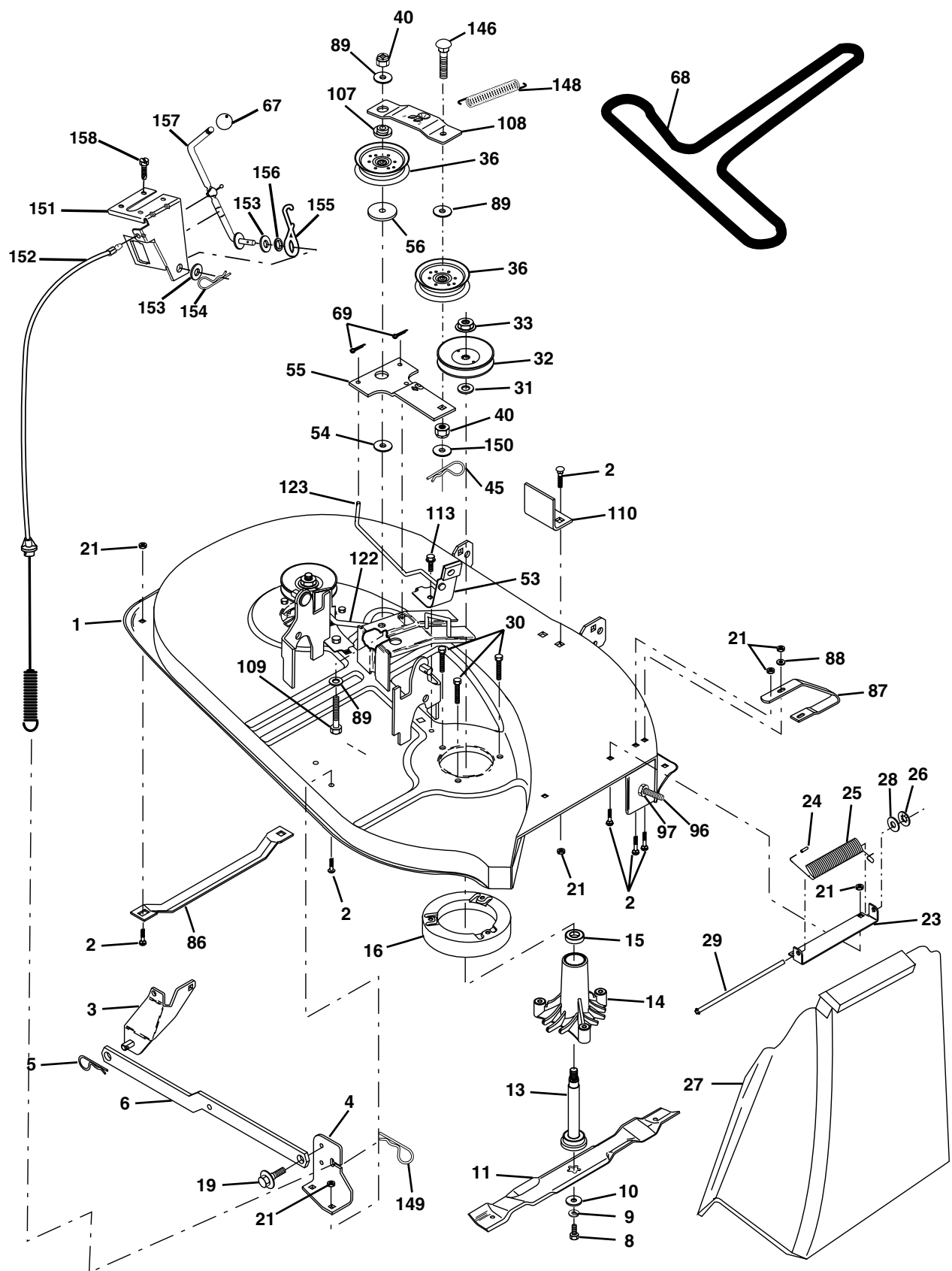



# REPAIR PARTS

TRACTOR - - MODEL NO. RE1196 (RE11T96A), PRODUCT NO. 964 79 78-00  
MOWER DECK

KEY NO.	PART NO.	DESCRIPTION	KEY NO.	PART NO.	DESCRIPTION
1	532 17 02-80	Mower Housing Assembly	68	532 18 02-14	V-Belt
2	872 14 05-06	Bolt Carriage 5/16-18 x 3/4	69	876 02 03-12	Pin, Cotter 3/32 x 3/4
3	532 13 80-17	Bracket Asm Fr. Sway Bar	86	532 12 50-74	Runner, LH
4	532 16 99-70	Bracket Deck Sway Bar 38"/42"	87	532 12 87-72	Runner, RH
5	532 12 46-70	Retainer Spring	88	819 11 12-16	Washer 11/32 x 3/4 x 16 Ga
6	532 17 80-24	Sway Bar Deck	89	819 13 16-12	Washer 13/32 x 1 x 12 Ga.
8	532 85 08-57	Bolt 3/8-24 x 1.25 Grade 8	96	874 93 06-20	Bolt 3/8-16 x 1-1/4
9	810 03 06-00	Washer, Lock 3/8	97	873 93 06-00	Nut Centerlock 3/8-16 Unc
10	532 14 02-96	Washer, Hardened	107	532 13 35-02	Spacer Retainer
11	532 13 84-97	Blade Mower	108	532 13 35-03	Stiffener, Idler Arm
13	532 13 76-45	Shaft Assembly, Mandrel, Vented (Includes Key Number 6)	109	874 76 06-40	Bolt, Hex Hd 3/8-16 x 2-1/2
14	532 12 87-74	Housing, Mandrel, Vented	110	532 14 25-87	Upstop Deck Front 38"
15	532 11 04-85	Bearing, Ball, Mandrel	113	817 06 05-12	Screw 5/16-1/ x 3/4
16	532 17 44-93	Stripper, Mower Deck	122	532 13 12-89	Rod, Brake LH
19	532 13 28-27	Bolt, Shoulder	123	532 16 99-71	Rod, Brake RH
21	873 68 05-00	Nut	146	532 16 58-91	Bolt Carriage Idler
23	532 13 76-07	Bracket, Mower Deflector	148	532 16 90-22	Spring Return Idler
24	532 10 53-04	Cap, Sleeve	149	532 16 58-98	Retainer Spring Yellow
25	532 12 37-13	Spring, Torsion, Deflector	150	819 09 12-16	Washer 9/32 x 3/4 x 16 Ga.
26	532 11 04-52	Nut, Push	151	532 16 96-70	Bracket Clutch Cable
27	532 17 59-43	Shield, Deflector	152	532 17 27-58	Clutch Cable 38"/46"
28	819 11 10-16	Washer 11/32 x 5/8 x 16 Gauge	153	532 16 96-74	Washer Flat 3/8" Type B
29	532 10 67-35	Rod, Hinge	154	532 16 96-75	Spring Retainer
30	532 17 39-84	Screw Thdrol. Hex	155	532 16 96-71	Spring Retention LVR CLTCH CAB
31	532 12 99-63	Washer, Spacer	156	532 16 96-72	Spacer Clutch Cable
32	532 15 35-32	Pulley, Mandrel	157	532 16 96-69	Rod Clutch Cable 3/8"
33	532 17 83-42	Nut, Toplock	158	817 72 04-08	Screw Hex Thd Cut 1/4-20 x 5/8
36	532 13 14-94	Pulley, Idler, Flat	--	532 13 07-94	Mandrel Assembly (Includes Housing, Shaft, and Shaft Hard- ware Only - Pulley Not Included)
40	873 68 06-00	Nut, Crownlock 3/8-16 Unc	--	532 18 13-80	Mower Replacement, Complete
45	532 12 47-88	Retainer			
53	532 13 08-40	Brake Assembly			
54	532 17 85-15	Washer, Hardened			
55	532 13 38-40	Idler Arm Assembly			
56	532 16 57-23	Spacer, Retainer			
67	532 10 69-32	Knob			

**NOTE:** All component dimensions given in U.S. inches  
1 inch = 25.4 mm

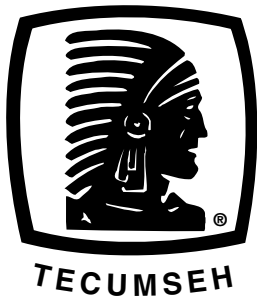

# SERVICE POLICY WARRANTY

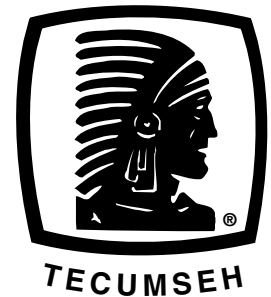

Issued January 1980  
Revised January 1991

## LIMITED WARRANTIES FOR NEW PEERLESS GEAR POWER TRAIN COMPONENTS

### A. Products Warranted

Peerless Gear and Machine Division of Tecumseh Products Company ("Tecumseh"), subject to the limitations contained below, will, at its option, repair or replace, without charge for parts or labor only, any part of a new Power Train Component (which as used herein means and includes the transaxle, gear box, transmission, differential and right angle drives, and any part of the Power Train Component), EXCEPT any new Power Train Component incorporated in equipment used for commercial or rental purposes, which is found upon examination by any Tecumseh Authorized Service Outlet or by Tecumseh's factory in Grafton, Wisconsin, to be DEFECTIVE IN MATERIAL AND/OR WORKMANSHIP if received by Tecumseh or a Tecumseh Authorized Service Outlet for such examination within TWO YEARS from the date of sale to the original consumer purchaser of Peerless Series 820, 900, 910, 915, 920, 930 transaxles and Series 1100 angle drive and ONE YEAR for all other Peerless products. New Power Train Components incorporated in equipment used for commercial purposes are warranted in the same manner and to the same extent EXCEPT such Power Train Components are warranted for NINETY (90) DAYS ONLY, and must be received by Tecumseh or by a Tecumseh Authorized Service Outlet for such examination within 90 days from the date of sale to the original purchaser. New Power Train Components Incorporated in equipment used for rental purposes are warranted in the same manner and to the same extent EXCEPT such Power Train Components are warranted for THIRTY (30) DAYS ONLY, and must be received by Tecumseh or a Tecumseh Authorized Service Outlet within 30 days from the date of sale to the original purchaser.

### B. Products And Items Not Warranted

1. Alterations or Modifications of Power Train Components.
2. Accidents, Normal Maintenance, Failure to follow the Original Equipment Manufacturer's Manual.

This warranty covers only parts of new Power Train Components which are found upon examination to be defective in material or workmanship as delivered to the original purchaser. This warranty does not cover defects caused by depreciation or damage caused by normal wear, accidents, improper maintenance, improper use or abuse of the product, failure to follow the instructions contained in an Instruction Manual for the operation of the Power Train Component and parts. The cost of normal maintenance and replacement of service items which are not defective shall be paid for by the original purchaser.

### C. Securing Warranty Service

Warranty service can be arranged for by contacting either a Tecumseh Authorized Service Outlet (any Tecumseh Registered Service Dealer, Tecumseh Authorized Service Distributor, or Tecumseh Central Warehouse Distributor) or by contacting Tecumseh, c/o Service Manager, Engine and Transmission Group Service Division, 900 North Street, Grafton, Wisconsin 53024. Warranty service can only be performed by a Tecumseh Authorized Service Outlet or by Tecumseh at its factory in Grafton, Wisconsin. At the time of requesting warranty service, evidence must be presented of the date of sale to the original purchaser. The purchaser shall pay any charges for making service calls and/or for transporting the product to and from the place where the inspection and/or warranty work is performed. The purchaser shall be responsible for any damage or loss incurred in connection with the transportation of Power Train Components and/or part(s) of the Power Train Components submitted for inspection and/or warranty work.

### D. Limitation of Damages and Implied Warranties

The foregoing EXPRESSED WARRANTY IS IN LIEU OF ALL OTHER EXPRESS WARRANTIES. Neither Tecumseh nor any of its affiliates makes any warranties, representations or promises, written or oral, as to the quality of the Power Train Component or any of its parts, other than as set forth herein.

ANY IMPLIED WARRANTY OF MERCHANTABILITY OR FITNESS FOR A PARTICULAR PURPOSE, TO THE EXTENT THAT EITHER MAY APPLY TO ANY PART(S) OF POWER TRAIN COMPONENTS, SHALL BE LIMITED IN DURATION TO THE PERIODS OF THE EXPRESSED WARRANTIES DEFINED IN PARAGRAPH A HEREOF. IN NO EVENT WILL TECUMSEH BE LIABLE FOR ANY INCIDENTAL, CONSEQUENTIAL OR SPECIAL DAMAGES AND/OR EXPENSES. Some states do not allow limitations on how long an implied warranty lasts or the exclusion or limitation of incidental or consequential damages, so the above limitation(s) or exclusion(s) may not apply to you. This warranty gives you specific legal rights and you may also have other legal rights which vary from state to state.

### E. No Dealer Warranty

Tecumseh neither assumes nor authorizes any other person, natural or corporate, to assume for Tecumseh any other obligations or liabilities in connection with or with respect to any part(s) of a Power Train Component. The seller or dealer of part(s) of a Power Train Component has no authority, whatsoever, to make any representations or promises on behalf of Tecumseh or to modify the terms or limitations of Tecumseh's warranty in any way.



**Rally**  
00137