

REPAIR PARTS MANUAL
MODEL NO. RE175H107RBK (96061021202)
Lawn Tractor

Rally

HOW TO USE THIS MANUAL

This manual is designed to provide the customer with a means to identify the parts on his/her tractor when ordering repair parts. The illustrations may or may not represent the actual assemblies; therefore, it is not recommended to use this manual as a guide to assemble or disassemble the tractor. Some hardware and parts are drawn larger in order to more readily identify them.

Each tractor has its own model number.

The model number for your tractor can be found on the fender under the seat.

When ordering parts, always give the following information:

- Product - "Tractor"
- Model Number - "RE175H107RBK" (96061021202)
- Part Number
- Part Description

TABLE OF CONTENTS

SCHEMATIC	3
ELECTRICAL.....	4-5
CHASSIS AND ENCLOSURES.....	6-7
DRIVE.....	8-9
STEERING ASSEMBLY.....	10-11
SEAT ASSEMBLY.....	12
DECALS.....	13
ENGINE.....	14-15
MOWER DECK	16-17
BAGGER.....	18
MOWER LIFT.....	19

TRACTOR - MODEL NO. RE175H107RBK(96061021202), PRODUCT NO. 960 61 02-12 SCHEMATIC

SCH08

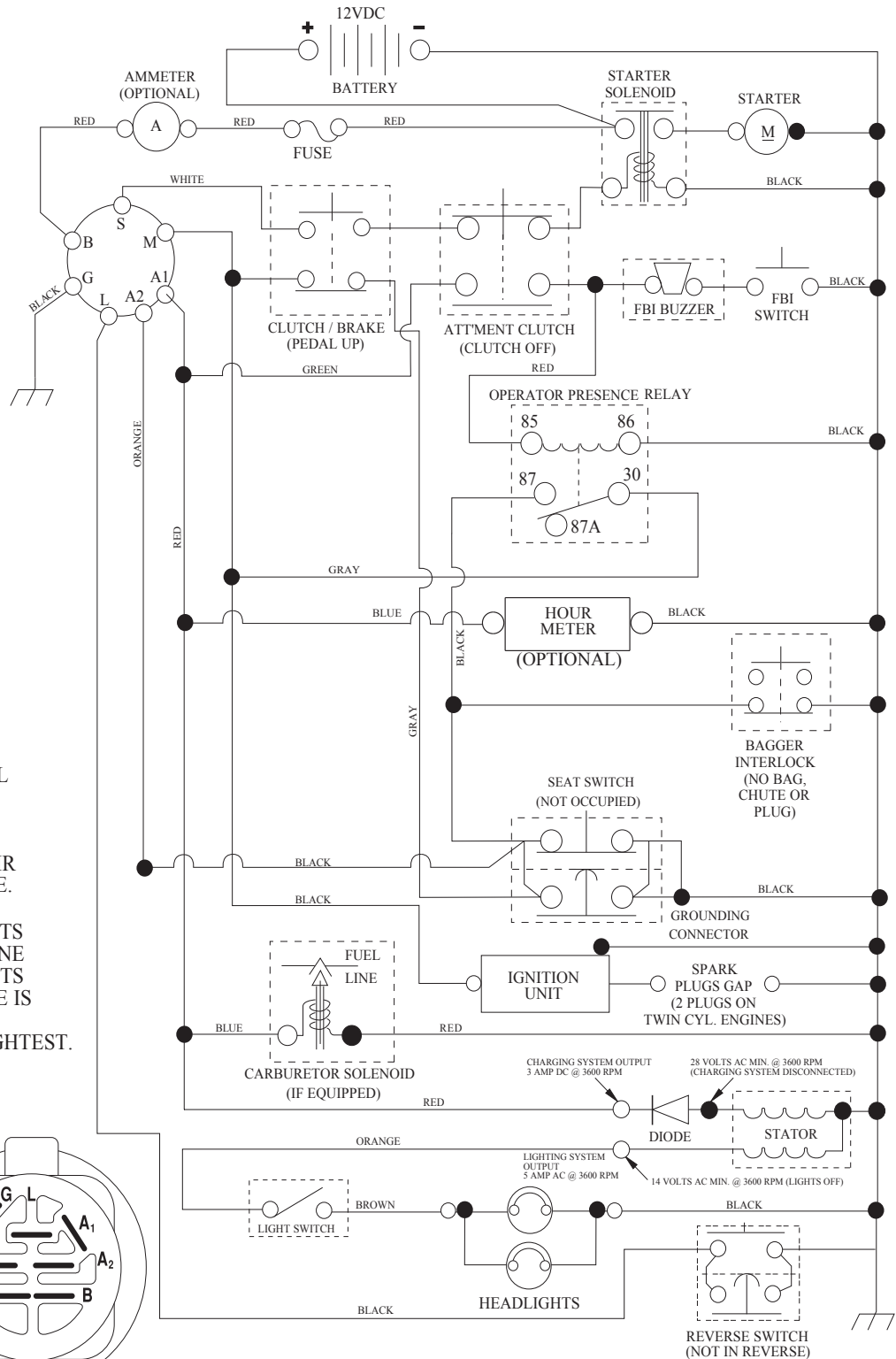

NOTE
YOUR TRACTOR IS EQUIPPED WITH A SPECIAL ALTERNATOR SYSTEM. THE LIGHTS ARE NOT CONNECTED TO THE BATTERY, BUT HAVE THEIR OWN ELECTRICAL SOURCE. BECAUSE OF THIS, THE BRIGHTNESS OF THE LIGHTS WILL CHANGE WITH ENGINE SPEED. AT IDLE THE LIGHTS WILL DIM. AS THE ENGINE IS SPEEDED UP, THE LIGHTS WILL BECOME THEIR BRIGHTEST.

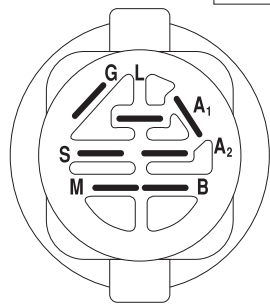

IGNITION SWITCH

POSITION	CIRCUIT	"MAKE"
OFF	M+G+A1	
RUN/OVERRIDE	B+A1	
RUN	B+A1	L+A2
START	B + S + A1	

WIRING INSULATED CLIPS
NOTE: IF WIRING INSULATED CLIPS WERE REMOVED FOR SERVICING OF UNIT, THEY SHOULD BE RE-INSTALLED TO PROPERLY SECURE YOUR WIRING.

REMOVABLE CONNECTIONS
NON-REMOVABLE CONNECTIONS

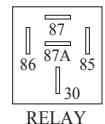

RELAY

**TRACTOR - MODEL NO. RE175H107RBK(96061021202), PRODUCT NO. 960 61 02-12
ELECTRICAL**

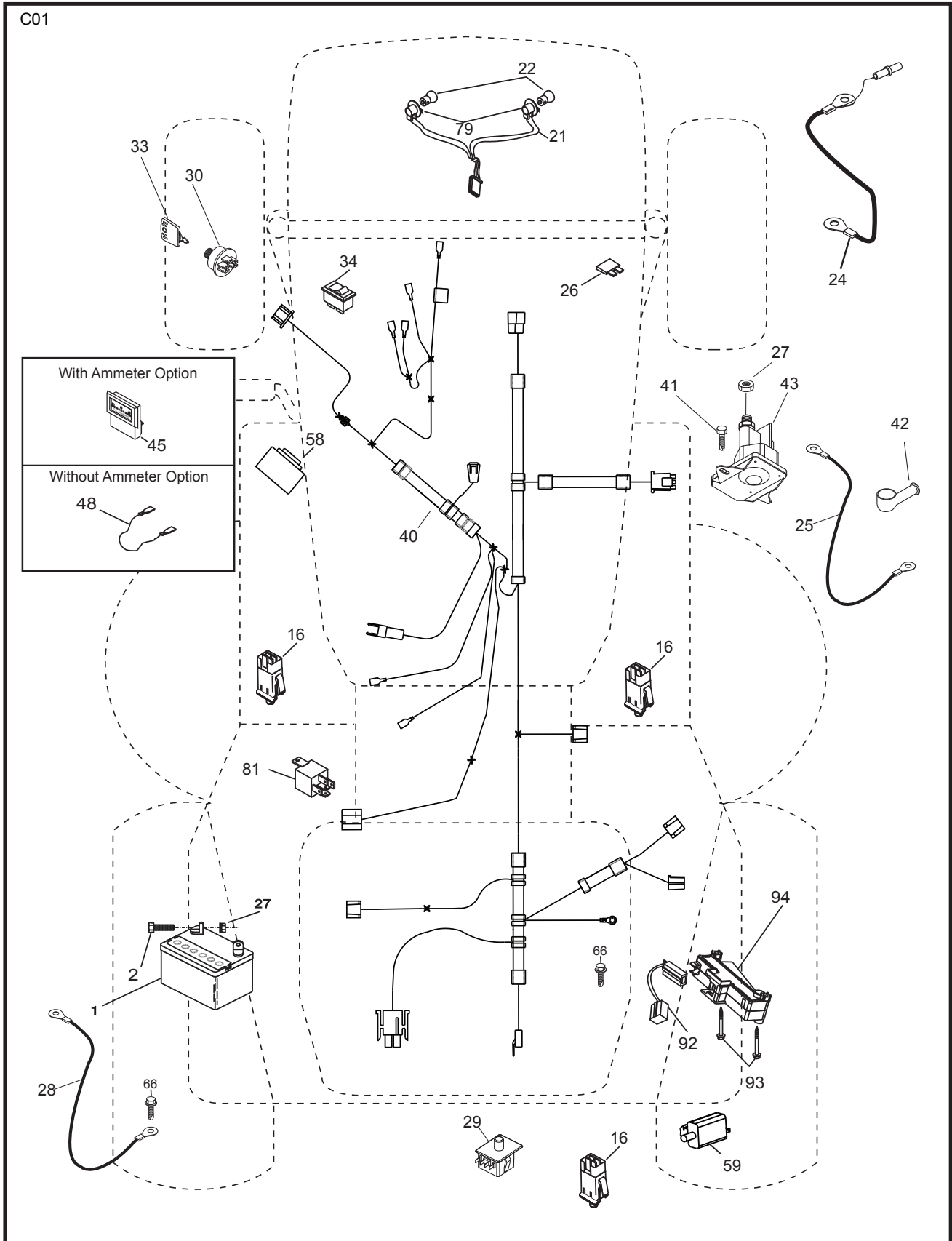

**TRACTOR - MODEL NO. RE175H107RBK(96061021202), PRODUCT NO. 960 61 02-12
ELECTRICAL**

KEY NO.	PART NO.	DESCRIPTION
1	532 16 34-65	Battery
2	874 76 04-12	Bolt Hex Hd 1/4-20 unc x 3/4
16	532 17 61-38	Switch Interlock
21	532 18 37-59	Harness Asm Light w/4152J
22	532 00 41-52	Bulb Light #1156
24	532 42 12-99	Cable Starter 6 Ga. 11" Red
25	532 16 59-87	Cable Battery CRD 56" Red
26	532 17 51-58	Fuse
27	873 51 04-00	Nut Keps Hex 1/4-20 unc
28	532 12 77-25	Cable Ground 6 Ga. 18" Black
29	532 19 27-49	Switch Seat
30	532 19 33-50	Switch Ignition
33	532 41 19-35	Key/Chain
34	532 11 07-12	Switch Light
40	532 19 74-36	Harness Ign
41	871 11 04-08	Bolt Flk Fin Hex 1/4-20 unc x 1/2
42	532 13 15-63	Cover Terminal Red
43	532 19 25-07	Solenoid
48	532 14 08-44	Adapter Ammeter Rectangular
58	532 16 94-19	Buzzer CRD
59	532 18 03-79	Switch FBI CRD
66	817 49 06-08	Screw Thdrol 3/8-16 x 1/2 Ty-Tt
79	532 17 52-42	Socket Asm Bulb Twistlock
81	532 10 97-48	Relay Asm
92	532 19 66-15	Harness Pigtail Console
93	532 19 25-40	Screw Plastite 10-24 x 2.0
94	532 19 18-34	Module Reverse ROS

NOTE: All component dimensions given in U.S. inches.
1 inch = 25.4 mm.

TRACTOR - MODEL NO. RE175H107RBK(96061021202), PRODUCT NO. 960 61 02-12
CHASSIS AND ENCLOSURES

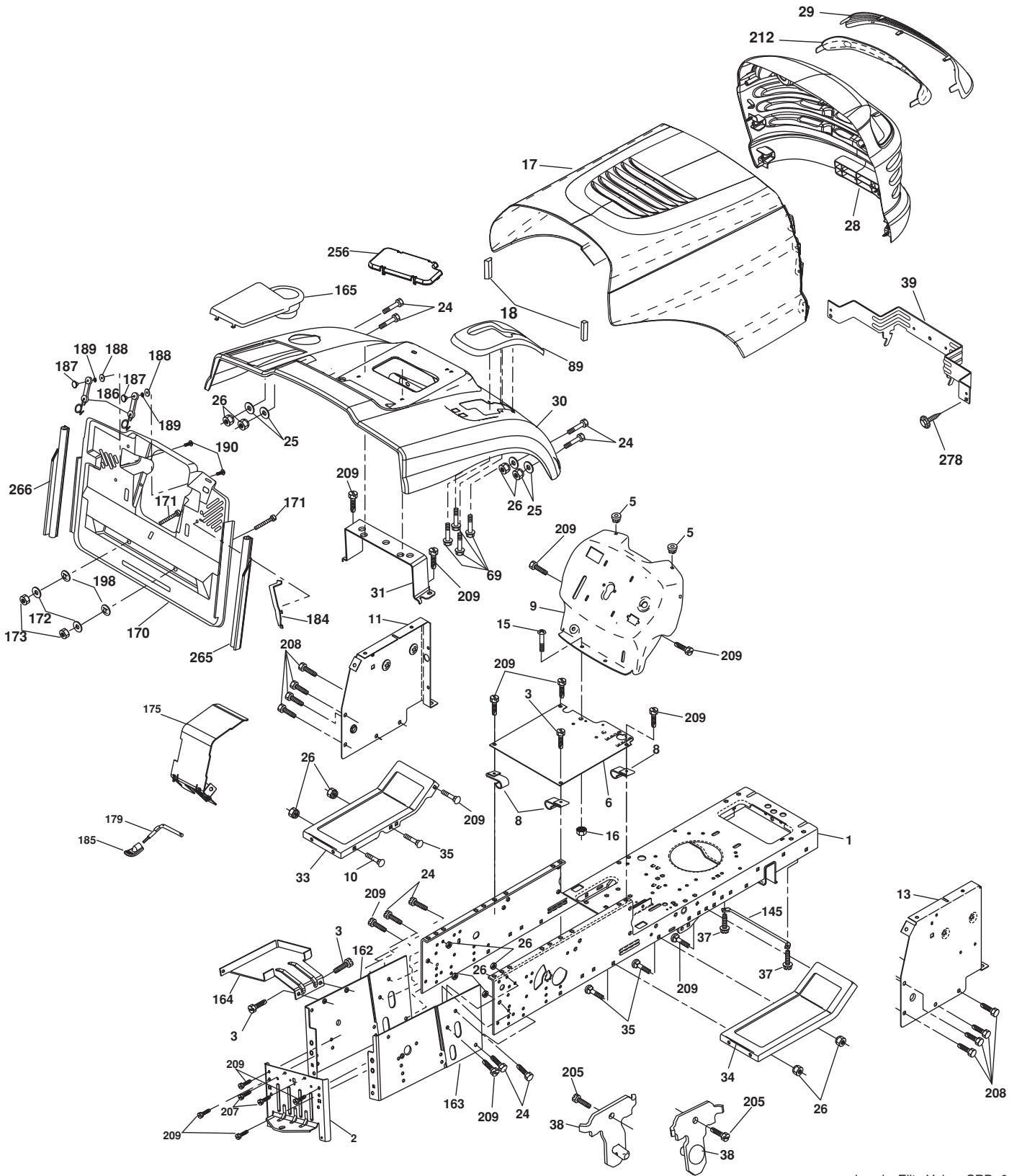

chassis_Elite Value_CRD_6

**TRACTOR - MODEL NO. RE175H107RBK(96061021202), PRODUCT NO. 960 61 02-12
CHASSIS AND ENCLOSURES**

KEY PART			KEY PART		
NO.	NO.	DESCRIPTION	NO.	NO.	DESCRIPTION
1	532 17 46-20	Chassis	163	532 18 03-83	Bracket Exten Chassis RH CRD
2	532 18 03-84	Drawbar	164	532 16 56-05	Support Battery CRD
3	817 06 06-12	Screw 3/8-16 x .75	165	532 18 13-56	Cover Battery CRD Lt
5	532 15 52-72	Bumper Hood/Dash	170	532 19 94-88	Backplate Asm CRD
6	532 18 44-19	Saddle	171	872 14 06-20	Bolt Rdhd Sqnk 3/8-16 x 2-1/2 Gr. 5
8	532 12 64-71	Clip Insulator 13/32 Mtg. Hole	172	819 13 20-16	Washer 13/32 x 1-1/4 x 16 Ga.
9	532 19 46-88	Dash	173	873 51 06-00	Nut, Keps Hex 3/8-16 unc
10	872 14 06-08	Bolt, Carriage 3/8-16 x 3/4	175	532 18 82-03	Trap Door CRD
11	532 17 49-96	Panel, Dash, LH	179	532 18 82-02	Rod Pivot FBI CRD
13	532 18 69-52	Panel, Asm. Dash RH	184	532 17 46-62	Bracket Actuator Bagger CRD
15	874 18 05-12	Screw, Machine, Truss Head 5/16-18 unc x 3/4	185	532 18 11-01	Knob Rod
16	873 51 05-00	Nut	186	532 16 07-93	Latch Asm Multch Bagger
17	532 18 67-07	Hood Assembly	187	532 12 50-04	Nut Weld .327/.304 #10-24
18	532 18 49-21	Bumper Hood	188	819 06 12-16	Washer #10
24	874 78 06-16	Bolt	189	810 07 10-00	Washer Lock #10
25	819 13 13-12	Washer 13/32 x 13/16 x 12 Ga.	190	871 08 10-10	Screw Pan Hd Phillips 10-24 x 5/8
26	873 80 06-00	Nut	198	532 16 89-37	Nut Push
28	532 18 35-52	Grille Lens Asm (Inc. Key #s 29, 212)	205	817 49 06-08	Screw 3/8-16 x 1/2
29	532 18 58-46	Lens	207	817 67 05-08	Screw Thdrol 5/16-18 x 1/2
30	532 19 73-44	Fender	208	817 67 06-08	Screw Thdrol 3/8-16 x 1/2
31	532 16 51-56	Bracket, Fender Support	209	817 00 06-12	Screw Hex Wsh Thdrol 3/8-16 x 3/4
33	532 18 11-93	Footrest, LH	212	532 18 35-50	Insert Lens Reflective
34	532 18 11-94	Footrest, RH	256	532 18 13-61	Cover Fender Rack CRD
35	872 11 06-06	Bolt	265	532 18 57-04	Seal RH Side Bagger
37	817 49 05-08	Screw Thdrol 5/16-18 x 1/2 TYT	266	532 18 57-03	Seal LH Side Bagger
38	532 18 17-48	Bracket Asm Pivot Mower Rear	278	532 41 63-58	Screw #10 x 0.750 BOS Thread
39	532 40 78-07	Bracket Pivot	--	532 00 54-79	Plug, Button
69	532 14 24-32	Screw Hex 1/4-1/2			
89	532 19 73-66	Console			
145	532 40 91-67	Rod Pivot Chassis/Hood			
162	532 18 03-82	Bracket Exten Chassis LH CRD			

NOTE: All component dimensions given in U.S. inches.
1 inch = 25.4 mm.

TRACTOR - MODEL NO. RE175H107RBK(96061021202), PRODUCT NO. 960 61 02-12
DRIVE

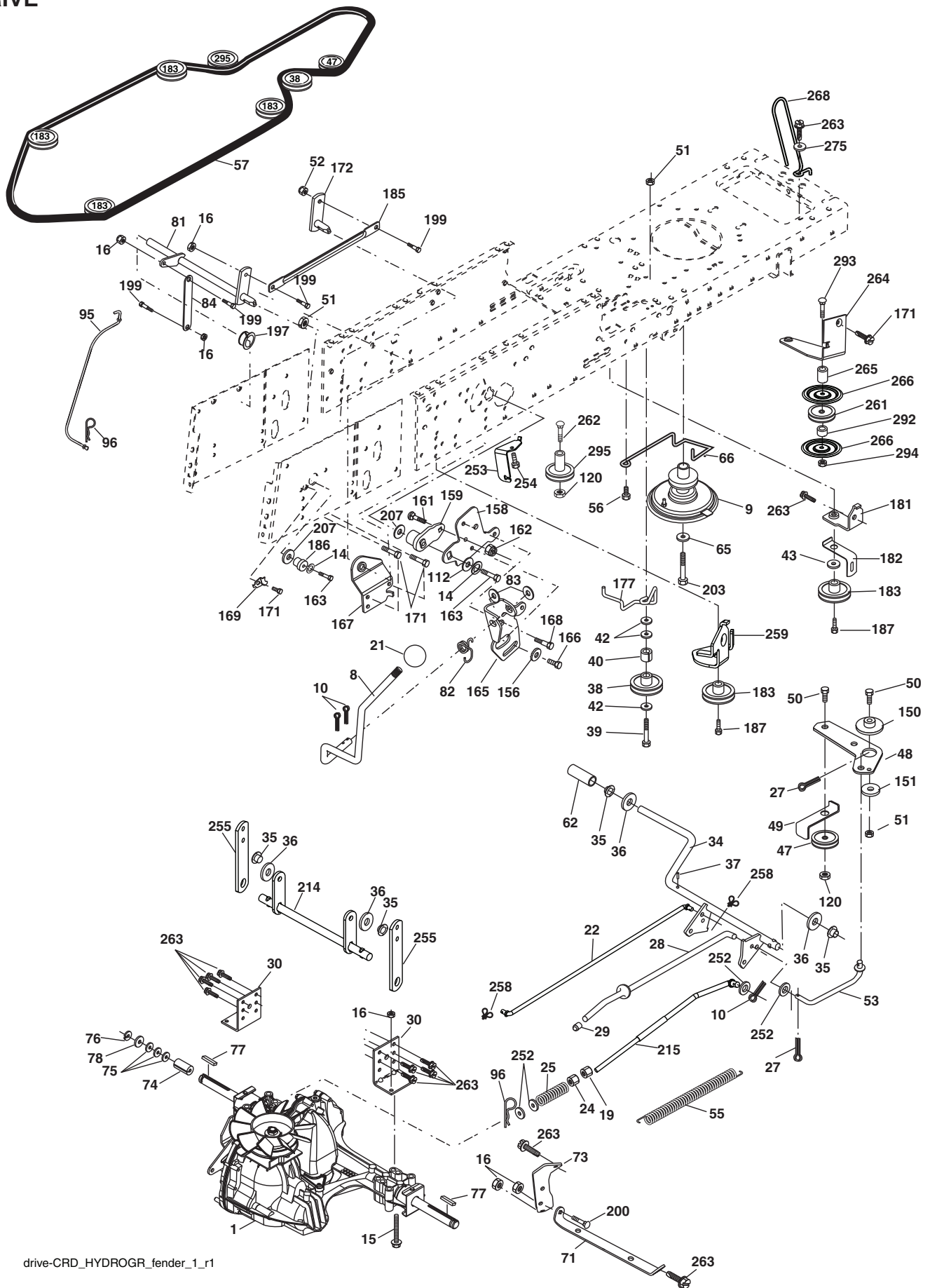

drive-CRD_HYDROGR_fender_1_r1

TRACTOR - MODEL NO. RE175H107RBK(96061021202), PRODUCT NO. 960 61 02-12 DRIVE

KEY PART NO.	NO.	DESCRIPTION	KEY PART NO.	NO.	DESCRIPTION
1	-----	Transaxle Hydro Gear 321-0510 (Order parts from transaxle manufacturer)	120	873 90 06-00	Nut Lock Flg. 3/8-16 unc
8	532 19 27-06	Rod, Shift	150	532 16 58-50	Bushing, Bellcrank Grnd Dr
9	532 40 85-79	Clutch Noram	151	819 13 32-10	Washer 13/32 x 2 x 10 Ga.
10	876 02 04-16	Pin, Cotter 1/8 x 1	156	532 16 60-02	Washer Srrted 5/16 ID x 1.125
14	810 04 04-00	Washer, Lock Hvy Helical	158	532 16 55-89	Bracket Shift Mount
15	874 49 05-44	Bolt Hex Flghd 5/16-18 Gr. 5	159	532 18 39-00	Hub Tapered Flange Shift Lt
16	873 80 05-00	Nut, Lock Hex w/Ins 5/16-18 unc	161	872 14 04-06	Bolt Rdhd Sqnk 1/4-20 x 3/4 Gr. 5
19	873 80 06-00	Nut Lock 3/8-16	162	873 68 04-00	Nut Crownlock 1/4-20 unc
21	532 10 69-33	Knob	163	874 78 04-16	Bolt Hex Fin 1/4-20 unc x 1 Gr. 5
22	532 17 56-07	Rod, Brake	165	532 16 56-23	Bracket Pivot Lever
24	873 35 06-00	Nut	166	817 49 05-10	Screw 5/16-18 x 5/8
25	532 19 20-36	Spring, Rod, Brake	167	532 16 55-88	Bracket Support Shift CRD
27	876 02 04-12	Pin, Cotter 1/8 x 3/4	168	532 16 54-92	Bolt Shoulder 5/16-18 x .561
28	532 17 57-65	Rod, Parking Brake	169	532 16 55-80	Plate Fastening Lt
29	532 07 16-73	Cap, Parking Brake	171	817 49 06-08	Screw Thdrol 3/8-16 x 1/2 Ty-Tt
30	532 16 95-92	Bracket, Mfg. Transaxle	172	532 17 02-71	Shaft Asm Shifter Frt CRD
34	532 17 55-78	Shaft, Asm Pedal Foot CRD	177	532 16 59-32	Keeper Flat Idler 3.06" CRD
35	532 12 01-83	Bearing, Nylon	181	532 18 02-11	Bracket Idler Ground Drive CRD
36	819 21 16-16	Washer 21/32 x 1 x 16 Ga.	182	532 18 26-82	Keeper Belt 2.5" V-Idler CRD
37	532 12 49-63	Pin, Roll 3/16 x 1"	183	532 19 95-32	Pulley V-Idler
38	532 16 59-36	Pulley Flat Composite 3.06"	185	532 17 00-08	Link Shift
39	874 76 06-44	Bolt Fin Hex 3/8-16 unc x 2-3/4	186	532 16 56-14	Hub Tapered Round CRD
40	532 12 49-65	Spacer, Split 395 x 59 Bzp	187	817 58 05-20	Screw Thdrol 5/16-18 x 1.25
42	819 13 13-12	Washer 13/32 x 13/16 x 12 Ga.	197	532 16 96-13	Nyliner Snap-In 5/8
43	819 11 10-12	Washer 11/32 x 5/8 x 12 Ga.	199	532 16 96-12	Bolt Shoulder 5/16-18 unc
47	532 12 77-83	Pulley, Idler, V Groove Plastic	200	872 14 05-08	Bolt RDHD SQNK 5/16-18 x 1
48	532 15 44-07	Bellcrank Clutch Grnd Drv	203	871 17 07-80	Bolt Hex 7/16-20 x 5
49	532 12 32-05	Retainer, Belt Style Spring	207	532 16 98-45	Washer Nylon Rear
50	872 11 06-12	Bolt Carr. Sh. 3/8-16 x 1-1/2 Gr. 5	214	532 17 56-09	Shaft Asm. Brake
51	873 68 06-00	Nut, Crownlock 3/8-16 unc	215	532 17 56-52	Rod Brake Hydro
52	873 6805-00	Nut Crownlock 5/16-18	252	819 13 16-16	Washer 13/32 x 1 x 16 Ga.
53	532 19 96-52	Link, Clutch 7.66	253	532 17 50-28	Bracket Cable Chassis
55	532 10 57-09	Spring, Return, Clutch	254	817 00 06-16	Screw 3/8-16 x 1
56	817 06 06-20	Screw 3/8-16 x 1-1/4	255	532 17 56-08	Brace Shaft Brake Mtg.
57	532 17 01-40	V-Belt Kev 112" 0650 CRD	258	532 17 80-62	Clip Retainer
62	532 12 48-72	Cover, Pedal	259	532 18 02-12	Bracket Pulley
65	810 04 07-00	Washer	261	532 13 14-94	Pulley Idler
66	532 15 47-78	Keeper, Belt Engine F-Proof	262	872 11 06-22	Bolt RDHD 3/8-16 unc x 2-3/4 Gr. 5
71	532 16 91-83	Strap, Torque, LH	263	817 00 06-12	Screw Hex Wsh Thdrol 3/8-16 x 3/4
73	532 16 91-82	Strap, Torque, RH	264	532 19 76-08	Bracket Edler Chassis
74	532 13 70-57	Spacer, Split	265	532 40 46-07	Spacer Idler Chassis
75	532 12 17-49	Washer 25/32 x 1-1/4 x 16 Ga.	266	532 18 20-61	Shield Idler
76	812 00 00-01	Ring, E	268	532 18 24-02	Guard Muffler OHV
77	532 12 35-83	Key, Square	275	819 13 16-14	Washer 13/32 x 1 x 14 Ga.
78	532 12 17-48	Washer 25/32 x 1-5/8 x 16 Ga.	292	532 40 02-71	Spacer
81	532 17 00-06	Asm, Shaft	293	872 14 06-28	Bolt 3/8-16 x 3-1/2
82	532 16 57-11	Spring, Torsion	294	532 19 70-33	Nut Jam 3/8-16
83	819 17 12-16	Washer 17/32 x 3/4 x 16 Ga.	295	532 17 91-14	Pulley Idler Composite
84	532 17 00-07	Link, Transaxle			
95	532 17 00-15	Control Asm Bypass Hydro			
96	532 12 47-88	Spring, Retainer 1"			
112	819 09 12-10	Washer 9/32 x 3/4 x 10 Ga.			

NOTE: All component dimensions given in U.S. inches.
1 inch = 25.4 mm.

**TRACTOR - MODEL NO. RE175H107RBK(96061021202), PRODUCT NO. 960 61 02-12
STEERING ASSEMBLY**

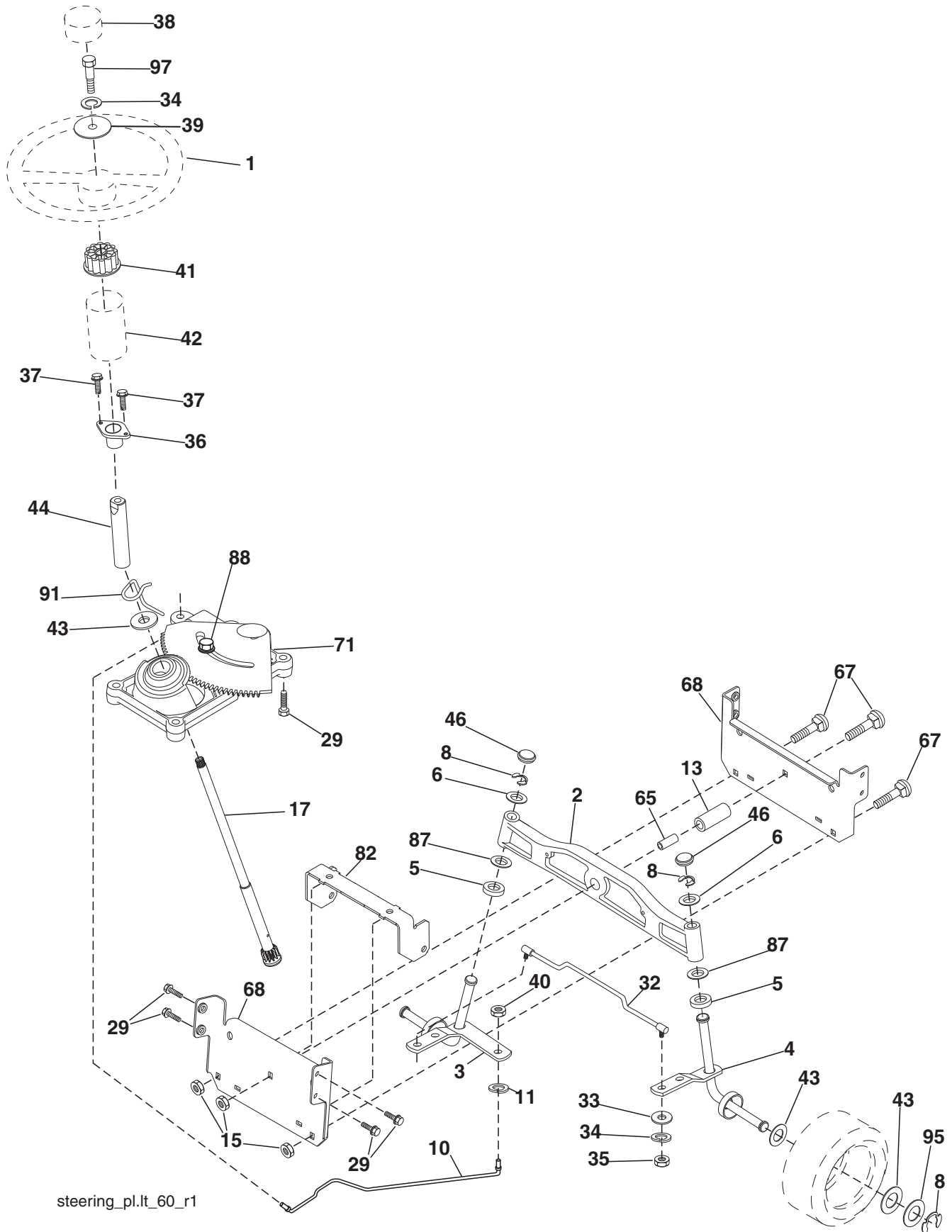

steering_pl.lt_60_r1

**TRACTOR - MODEL NO. RE175H107RBK(96061021202), PRODUCT NO. 960 61 02-12
STEERING ASSEMBLY**

KEY PART NO.	PART NO.	DESCRIPTION
1	532 18 67-80	Steering Wheel
2	532 18 47-06	Cast Iron Axle Assembly
3	532 16 98-40	Spindle Assembly, LH
4	532 16 98-39	Spindle Assembly, RH
5	532 12 49-31	Bearing, Race, Thrust, Hardened
6	532 12 17-48	Washer 25/32 x 1-5/8 x 16 Ga.
8	812 00 00-29	Ring, Klip
10	532 17 51-21	Link, Drag
11	810 04 06-00	Washer, Lock
13	532 13 65-18	Spacer Brg Axle Front
15	532 14 52-12	Nut, Hexflange Lock
17	532 19 07-53	Shaft Assembly, Steering
29	817 00 06-12	Screw, 3/8-16 x 3/4
32	532 17 01-62	Rod, Tie
33	819 11 12-16	Washer 11/32 x 3/4 x 16 Ga.
34	810 04 05-00	Washer Lock Hvy Hlcl Spr 5/16
35	873 54 05-00	Nut Crownlock 5/16-24 unf
36	532 15 50-99	Bushing, Steering
37	532 15 29-27	Screw TT #10-32 x 5 x 3/8 Flange
38	532 19 29-16	Cap Wheel Steering
39	819 11 38-12	Washer 11/32 x 2-3/8 x 12 Ga.
40	873 54 06-00	Nut Crownlock 3/8-24
41	532 18 67-37	Adaptor, Steering Wheel
42	532 16 96-33	Boot, Steering Dash P/L Mtl
43	532 12 17-49	Washer 25/32 x 1-1/4 x 16 Ga.
44	532 19 07-52	Extension Steering
46	532 12 12-32	Cap, Spindle
65	532 41 47-36	Spacer Brace Axle
67	872 11 06-18	Bolt Rdhd Sq 3/8-16 unc x 2-1/4
71	532 17 51-46	Steering Asm.
68	532 16 98-27	Brace Axle
82	532 19 99-78	Bracket Susp Chassis Front
87	532 17 39-66	Washer Flat .781 x 1-1/2 x .14
88	532 17 51-18	Bolt Shoulder 7/16-20 unc
91	532 17 55-53	Clip Steering
95	532 18 89-67	Washer Harden .793 x 1.637 x .060
97	874 78 05-64	Bolt 5/16-18 unc x 4L Gr. 5

NOTE: All component dimensions given in U.S. inches.
1 inch = 25.4 mm.

**TRACTOR - MODEL NO. RE175H107RBK(96061021202), PRODUCT NO. 960 61 02-12
SEAT ASSEMBLY**

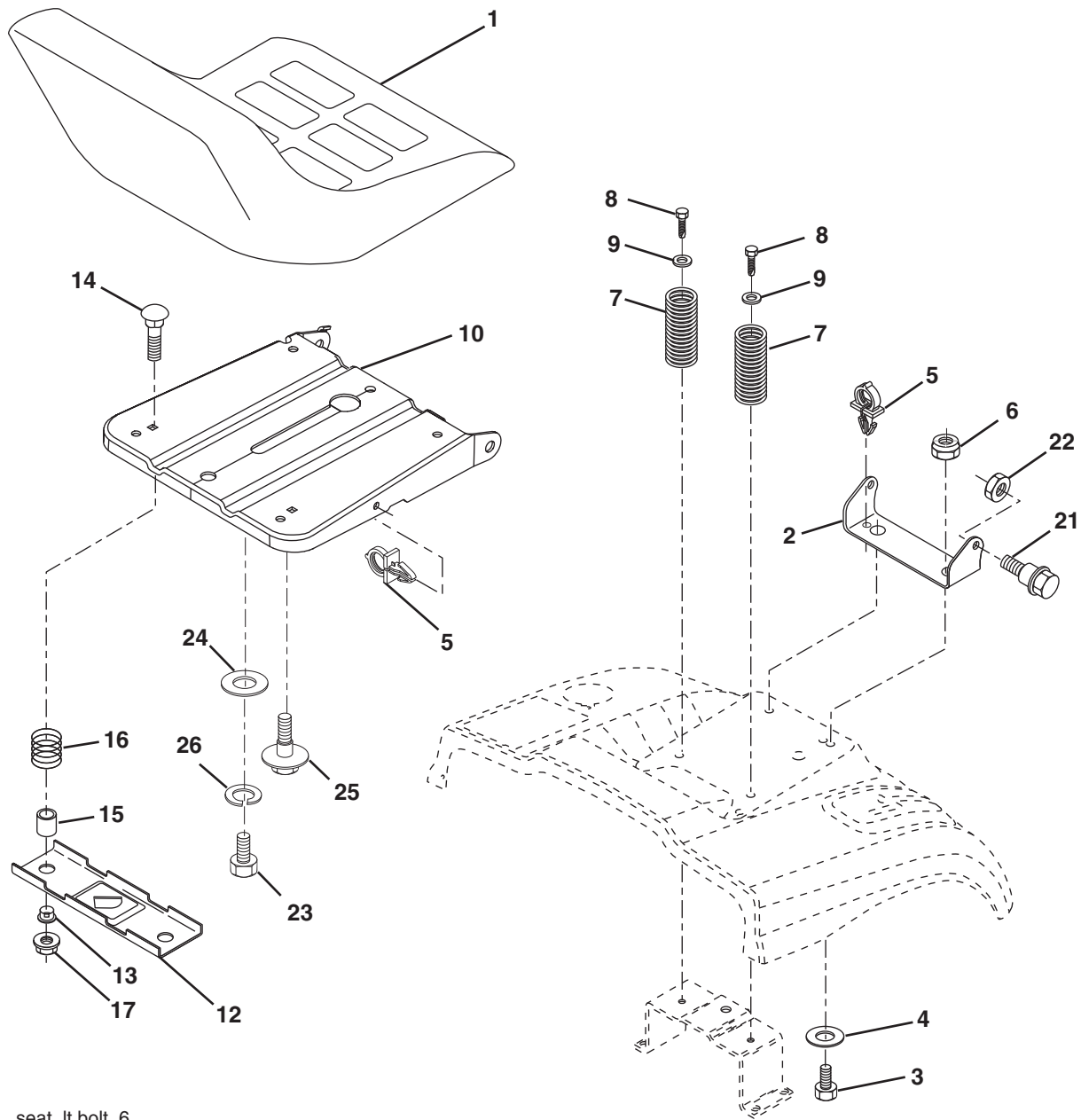

seat_lt.bolt_6

KEY PART NO.	NO.	DESCRIPTION
1	532 18 87-13	Seat
2	532 14 05-51	Bracket Pnt Pivot Seat
3	871 11 06-16	Bolt Fin Hex 3/8-16 unc x 1
4	819 13 16-10	Washer Flat 13/32 x 1 x 10 Ga.
5	532 14 50-06	Clip Push In Hinged
6	873 80 06-00	Nut Lock Hex 3/8-16 unc
7	532 12 41-81	Spring Seat Cprsn 2 250 Blk Zi
8	817 00 06-16	Screw 3/8-16 x 1-1/2
9	819 13 16-14	Washer 13/32 x 1 x 14 Ga.
10	532 19 55-30	Pan Pnt Seat
12	532 17 46-48	Bracket Pnt Mounting Switch
13	532 12 12-48	Bushing Snap Blk Nyl 50 Id

KEY PART NO.	NO.	DESCRIPTION
14	872 05 04-12	Bolt Rdhd Sht Nk 1/4-20 x 1-1/2
15	532 13 43-00	Spacer Split
16	532 12 12-50	Spring Cprsn
17	532 12 39-76	Nut Lock 1/4 Lge Flg Gr. 5 Zinc
21	532 17 18-52	Bolt Shoulder 5/16-18 unc-2A
22	873 80 05-00	Nut Hex Lock w/Ins 5/16-18
23	871 11 08-14	Bolt Hex Black
24	819 17 19-12	Washer 17/32 X 1-3/16 x 12 Ga.
25	532 12 70-18	Bolt Shoulder 5/16-18 x 62
26	810 04 08-00	Washer Lock Hvy HLCL Spr. 1/2

NOTE: All component dimensions given in U.S. inches.
1 inch = 25.4 mm

**TRACTOR - MODEL NO. RE175H107RBK(96061021202), PRODUCT NO. 960 61 02-12
DECALS**

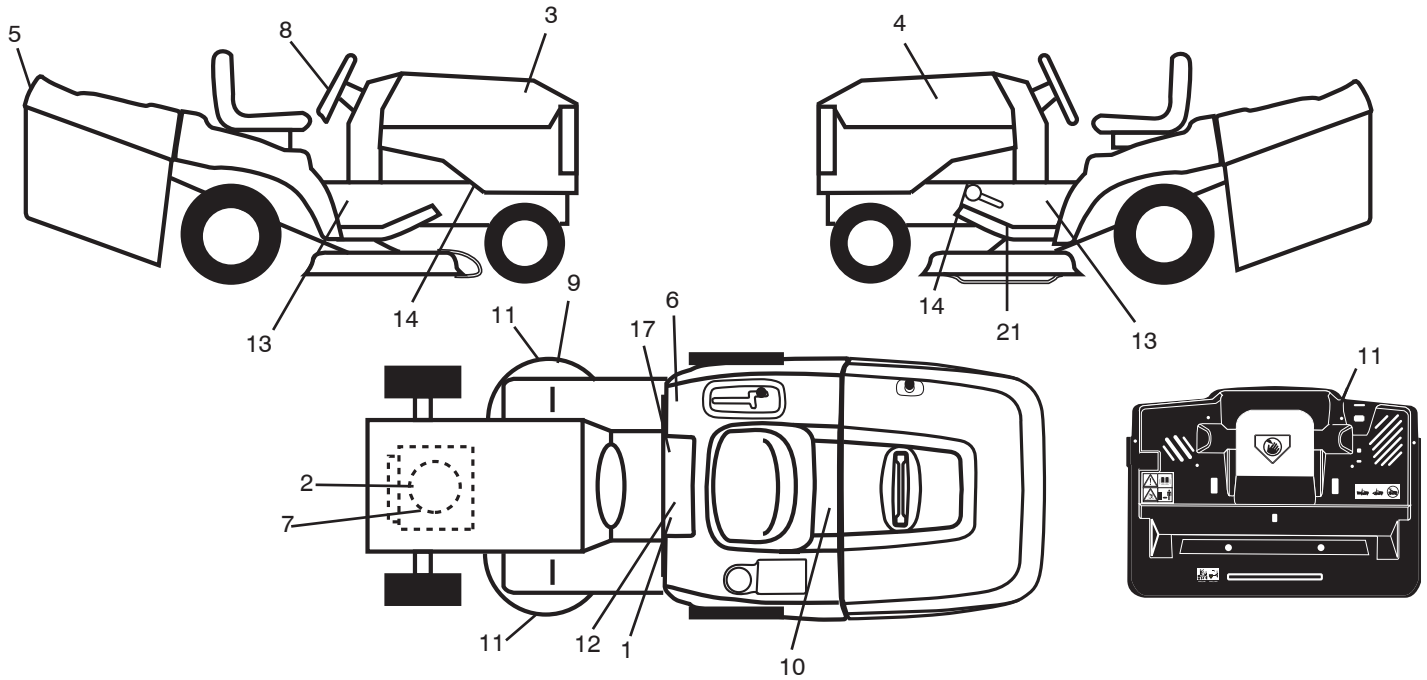

KEY PART NO.	NO.	DESCRIPTION
1	532 40 03-89	Decal, Warning Sym CE
2	532 41 67-28	Decal, Hp Engine
3	532 18 76-20	Decal, Hood RH
4	532 18 76-21	Decal, Hood LH
5	532 18 11-46	Decal, Fender
6	532 18 04-32	Decal, 100 DBA
7	532 19 68-41	Decal, Warning Engine
8	532 40 22-26	Decal, Steering
9	532 18 78-11	Decal, Deck Enviro
10	532 14 50-05	Decal, Bat Dan/Poi P/L Sym Wpn
11	532 18 21-66	Decal, Mower Cut Finger Symbol
12	532 15 97-37	Decal, Brake/Clutch Symbol Lt
13	532 18 96-94	Decal, Chassis

KEY PART NO.	NO.	DESCRIPTION
14	532 15 97-36	Decal, Chassis Hot Muffler
17	532 14 08-37	Decal, Saddle Brake Parking
21	532 16 62-86	Decal, Hex Belt Sch
—	532 18 10-91	Pad, Footrest LH
—	532 18 10-90	Pad, Fotrest RH
—	532 16 69-60	Decal, Bypass Fender CRD
—	532 13 83-11	Decal, Lift Handle
—	532 18 04-35	Decal, Rear Plate
—	532 40 09-09	Manual, Operator's (Euro)
—	532 40 09-10	Manual, Operator's (Scand)
—	532 41 19-56	Manual, Operator's (Ebloc)
—	532 41 19-57	Manual, Operator's (Baltic)
—	532 42 43-64	Manual, Parts

WHEELS & TIRES

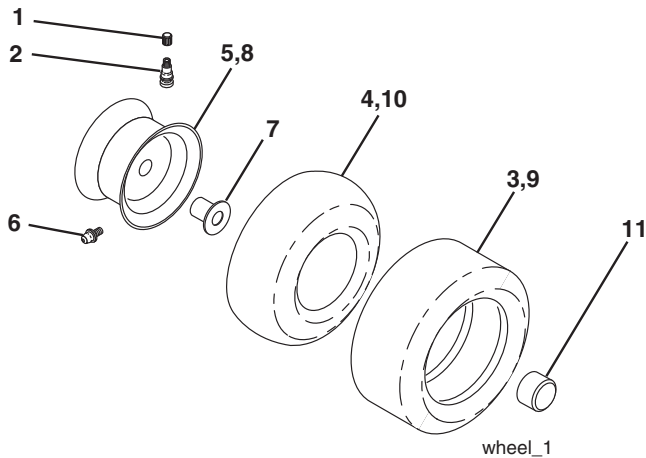

KEY PART NO.	NO.	DESCRIPTION
1	532 05 91-92	Cap Valve Tire
2	532 06 51-39	Stem Valve
3	532 10 62-22	Tire F Ts 15 x 6 0 - 6 Service
4	532 05 99-04	Tube Inner Front #35060
5	532 18 33-37	Rim Asm 6" Front Service
6	532 12 49-57	Fitting Grease
7	532 12 49-59	Bearing Flange
8	532 18 33-38	Rim Asm 8" Rear Service
9	532 13 84-68	Tire R Ts 20 x 8-8 Service
10	532 12 49-26	Tube Rear 9 5 x 8 Service
11	532 17 50-39	Cap Axle Blk 1 50 x 1 00
--	532 14 43-34	Sealant, Tire (10 oz. tube)

NOTE: All component dimensions given in U.S. inches
1 inch = 25.4 mm

**TRACTOR - MODEL NO. RE175H107RBK(96061021202), PRODUCT NO. 960 61 02-12
ENGINE**

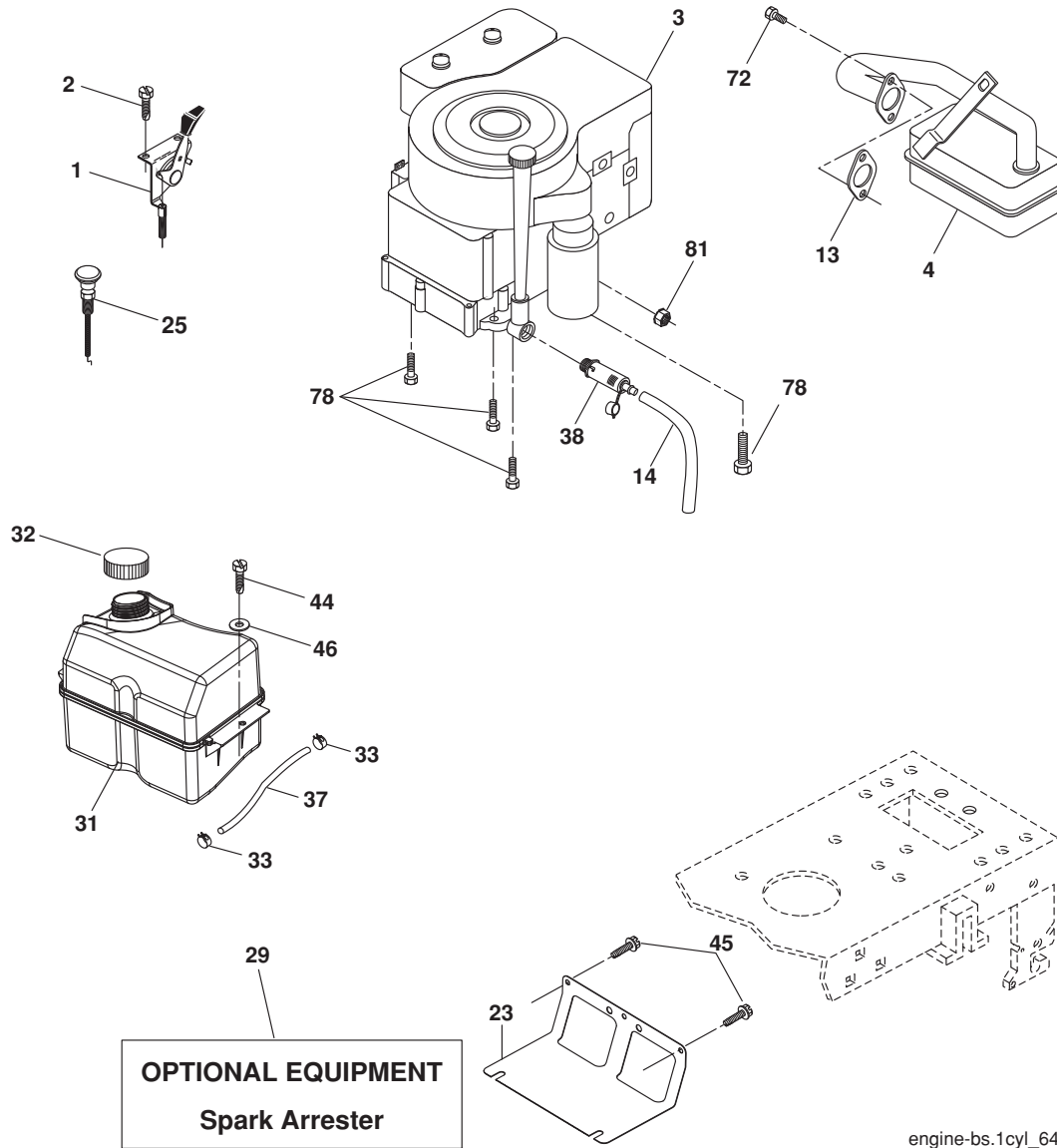

engine-bs.1cyl_64

**TRACTOR - MODEL NO. RE175H107RBK(96061021202), PRODUCT NO. 960 61 02-12
ENGINE**

KEY PART NO.	PART NO.	DESCRIPTION
1	532 17 05-51	Control Throt Flag
2	817 72 04-08	Screw Hex Thd Cut 1/4-20 x 1/2
3	-----	Engine B&S Model 31C707 (Order Parts from Engine Manufacturer)
4	532 13 73-52	Muffler Exhaust
13	532 16 52-91	Gasket Muffler
14	532 14 84-56	Tube Drain Oil Easy
23	532 16 98-37	Shield BRN/DBR Guard
25	532 19 06-95	Control Choke
29	532 13 71-80	Arrestor Spark
31	532 40 75-51	Tank Fuel Front 2.00 Gal.
32	532 19 77-25	Cap Fuel Asm Top Vent
33	532 12 34-87	Clamp Hose Blk
37	532 13 70-40	Line Fuel
38	532 18 16-54	Plug Drain Oil Easy
44	817 67 04-12	Screw Hexwsh Thdrol 1/4-20 x 3/4
45	817 00 06-12	Screw 3/8-16 x 3/4
46	819 09 14-16	Washer 9/32 x 7/8 x 16 Ga.
72	532 19 23-34	Screw Socket Head 5/16-18 x .75
78	817 06 06-20	Screw 3/8-16 x 1-1/4
81	873 51 04-00	Nut Keps 1/4-20 unc

NOTE: All component dimensions given in U.S. inches
1 inch = 25.4 mm

Engine Power Rating Information

The gross power rating for individual gas engine models is labeled in accordance with SAE (Society of Automotive Engineers) code J11940 (Small Engine Power & Torque Rating Procedure), and rating performance has been obtained and corrected in accordance with SAE J1995 (Revision 2002-5). Actual gross engine power will be lower and is affected by, among other things, ambient operating conditions and engine-to-engine variability. Given both the wide array of products on which engines are placed and the variety of environmental issues applicable to operating the equipment, the gas engine will not develop the rated gross power when used in a given piece of power equipment (actual "on-site" or net horsepower). This difference is due to a variety of factors including, but not limited to, accessories (air cleaner, exhaust, charging, cooling, carburetor, fuel pump, etc.), application limitations, ambient operating conditions (temperature, humidity, altitude), and engine-to-engine variability. Due to manufacturing and capacity limitations, Briggs & Stratton may substitute an engine of higher rated power for this Series engine.

**TRACTOR - MODEL NO. RE175H107RBK(96061021202), PRODUCT NO. 960 61 02-12
MOWER**

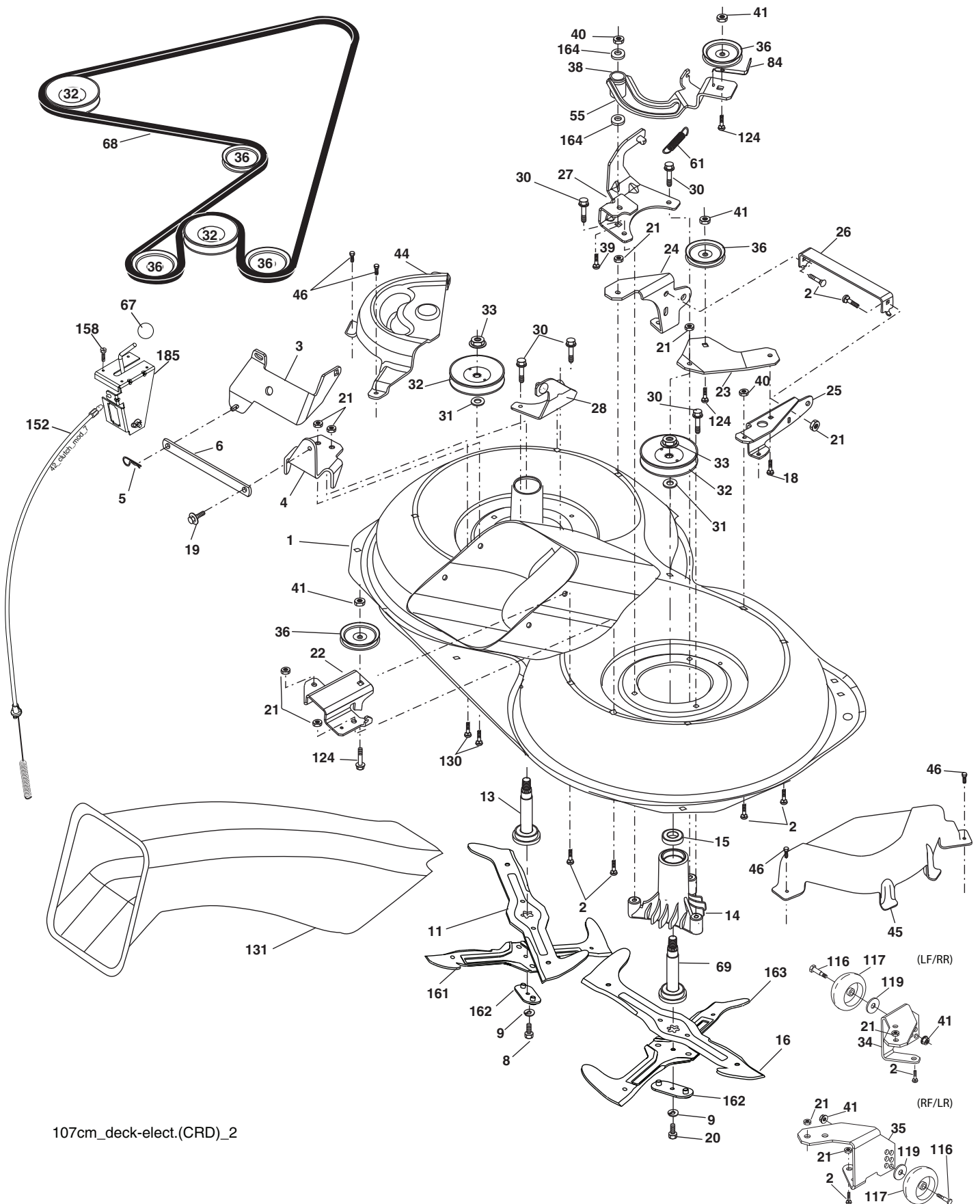

**TRACTOR - MODEL NO. RE175H107RBK(96061021202), PRODUCT NO. 960 61 02-12
MOWER**

KEY PART NO. NO.	DESCRIPTION
1	532 16 91-60 Housing Asm. Mower
2	872 14 05-06 Bolt Rdhd Sqnk 5/16-18 unc x 3/4
3	532 16 55-69 Bracket Asm. S-Bar Chass
4	532 16 91-67 Bracket Bar Sway Deck
5	532 12 46-70 Retainer Spring
6	532 16 55-57 Bar Sway
8	532 18 17-13 Bolt 3/8-24 x 1.25 Gr. 8 Patched
9	810 03 06-00 Washer Lock Hvy 3/8 Unplated
11	532 18 05-83 Blade 3-1 LH
13	532 13 76-45 Shaft Asm. w/Lower Bearing
14	532 12 87-74 Housing Mandrel Vented (Machd)
15	532 11 04-85 Bearing Ball Mandrel
16	532 18 05-84 Blade 3-1 RH
18	872 11 06-06 Bolt RDHD SQNK 5/16-16 unc x 3/4
19	532 13 28-27 Bolt Shoulder 5/16-18 Thd Form
20	532 18 17-12 Bolt 3/8-24 x 1.25 Gr. 8 Ptch LH Thd
21	873 68 05-00 Nut Crown Lock 5/16-18
22	532 16 91-65 Bracket Idler RR
23	532 16 91-66 Bracket Idler RF
24	532 41 34-36 Bracket Suspension LF
25	532 40 01-05 Bracket Suspension RF
26	532 40 01-10 Brace Susp Frt CRD
27	532 16 91-72 Bracket Asm. Susp RR
28	532 16 91-68 Bracket Asm. Susp LR
30	532 17 39-84 Screw Thd Rolling
31	532 18 76-90 Washer Spacer
32	532 19 81-45 Mandrel Pulleys
33	532 40 02-34 Nut Flg Top Lock
34	532 40 01-03 Bracket Gauge Wheel LF
35	532 40 01-04 Bracket Gauge Wheel RF
36	532 14 67-63 Pulley Idler V-Groove Dim 4.25
38	532 16 98-51 Spacer Hub Arm Idler 107 CRD
39	872 11 06-22 Bolt Rdhd 3/8-16 unc x 2-3/4 Gr. 5

KEY PART NO. NO.	DESCRIPTION
40	873 68 06-00 Nut Crownlock 3/8-16 unc
41	873 90 06-00 Nut Lock Flg. 3/8-16 unc
44	532 17 55-38 Cover Mandrel LH
45	532 17 55-39 Cover Mandrel RH
46	532 13 77-29 Screw Thd Roll 1/4-20 x 5/8
55	532 16 98-49 Arm Idler 107 CRD
61	532 19 94-87 Spring Tension Belt
67	532 10 69-32 Knob Rd 3/8-16 Plstc Thds Blk
68	532 40 20-09 Hex-Belt Mower
69	532 16 54-82 Shaft Asm w/Lwr Brg RH Thd CRD
84	532 15 60-85 Keeper Belt Idler
116	532 19 34-06 Bolt Shoulder
117	532 17 48-73 Wheel Gauge
119	819 13 20-12 Washer 13/32 x 1-1/4 x 12 Ga.
124	872 11 06-12 Bolt Carr Sh 3/8-16 x 1-1/2 Gr. 5
130	872 11 05-06 Bolt Rdhdsqnk 5/16-18 unc x 3/4
131	532 16 56-61 Chute Bagger CRD 92 cm
152	532 17 60-74 Cable Clutch CRD Service
158	817 72 04-08 Screw Hex Thdcut 1/4-20 x 1/2
161	532 18 04-24 Blade Cross LH
162	532 18 08-78 Adapter Weldment Blade
163	532 18 04-25 Blade Cross RH
164	532 12 49-37 Bearing Col Strg
185	532 18 82-34 Head Asm Cable Clutch
--	532 18 18-57 Mandrel Asm Service
--	532 18 18-58 Mandrel Asm CRD LH Threads SVC
--	532 40 03-25 Deck Mower Complete (Std. Deck - Order separately gauge wheel components key nos. 116-119)

NOTE: All component dimensions given in U.S. inches.
1 inch = 25.4 mm.

**TRACTOR - MODEL NO. RE175H107RBK(96061021202), PRODUCT NO. 960 61 02-12
BAGGER**

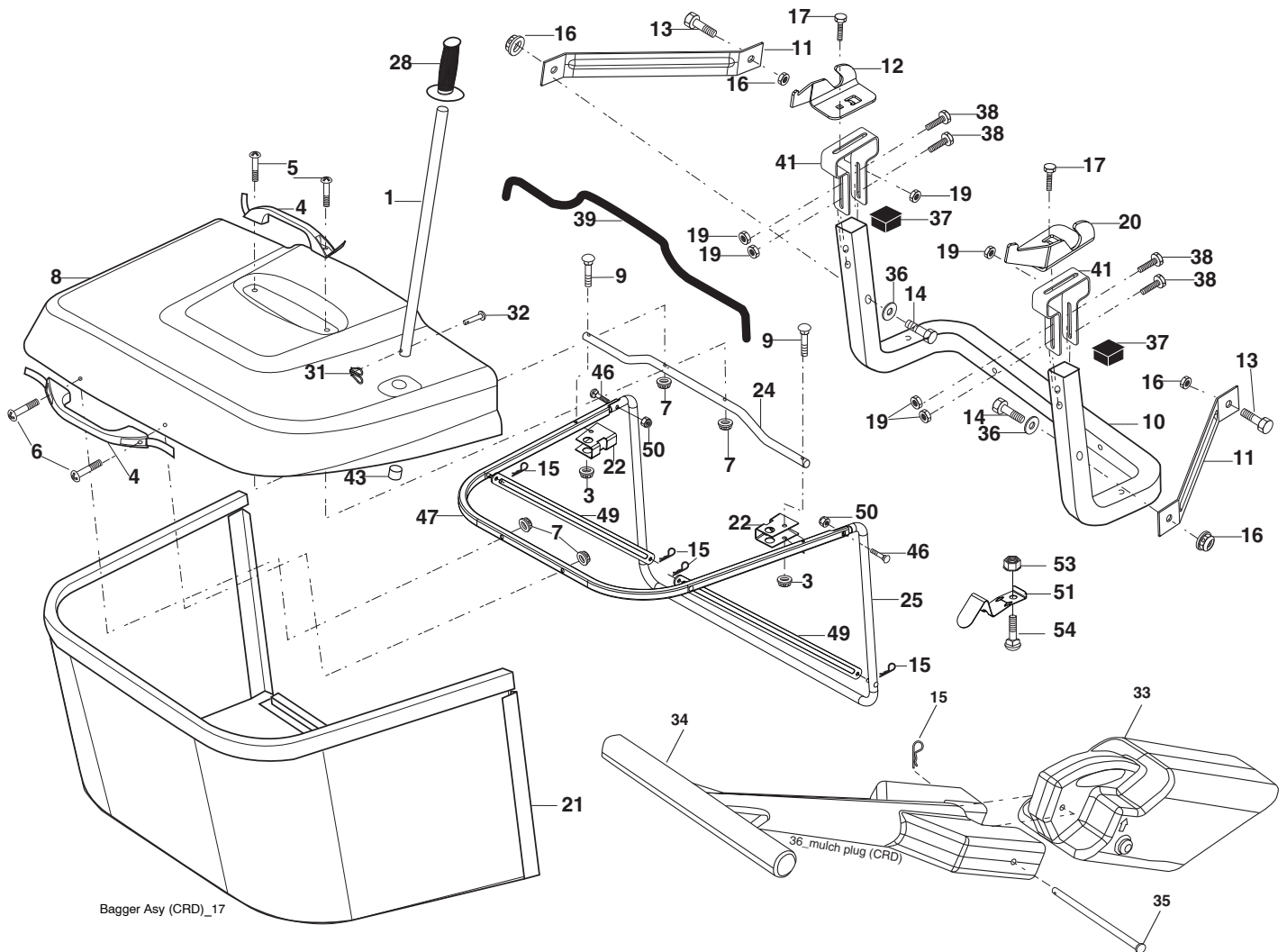

Bagger Asy (CRD)_17

KEY PART NO.	NO.	DESCRIPTION
1	532 16 52-49	Tube Handle Bagger CRD
2	872 14 04-16	Bolt Carriage 1/4-20 x 2.0 Gr. 5
3	532 12 39-76	Nut Lock 1/4 Lge Flg Gr. 5 Zinc
4	532 16 99-16	Handle Bagger w/Lvrs Gr. 5 Zinc
5	874 98 10-24	Screw Pan Head #10-24 x 1.50 Blk
6	874 98 10-32	Screw Pan Hd
7	873 40 10-00	Nut Wiz Lock Hex Serr/Hd #10-24
8	532 18 13-54	Cover Bagger
9	872 14 04-18	Bolt Carriage 1/4-20 x 2.25d x Gr. 5
10	532 18 12-82	Tube Support Bagger CRD
11	532 16 57-19	Bracket Support Upper Bag CRD
12	532 18 88-48	Bracket Pivot LH
13	874 76 06-12	Bolt Fin Hex 3/8-16 unc x 3/4
14	874 52 06-36	Bolt Fin Hex 3/8-16 x 2 x 1/4 Gr. 5
15	532 12 46-70	Retainer Spring
16	873 90 06-00	Nut Fock Flg 3/8-16 unc
17	872 14 05-06	Bolt Rdhd Sht Sqnk 5/16-18 unc x 3/4
19	873 90 05-00	Nut Lock Hex Flange 5/16-18
20	532 18 88-47	Bracket Pivot RH
21	532 40 61-80	Bag Asm CRD
22	532 16 57-81	Bracket Side Bagger CRD
23	532 16 57-82	Tube Upper Bagger CRD
24	532 16 57-83	Tube Pivot Bagger CRD

KEY PART NO.	NO.	DESCRIPTION
25	532 19 37-05	Tube Front Bagger CRD
28	532 16 57-87	Grip Handle Black
31	532 16 94-84	Retainer Clip
32	532 12 68-75	Rivet Rd Hd Drilled 3/8 Dia
33	532 16 93-80	Plug Mulch 107
34	532 16 55-70	Handle Mulcher
35	532 16 55-72	Pin Mulcher
36	819 13 20-12	Washer 13/32 x 1-1/4 x 12 Ga.
37	532 17 54-01	Plug Support Bagger CRD
38	872 01 05-20	Bolt 5/16-18 x 2-1/2
39	532 41 62-57	Seal
41	532 16 96-83	Bracket Vert Adj Bagger CRD
43	532 17 40-83	Plug Tubing End
46	872 11 05-10	Bolt 5/16-18 x 1-1/4 Gr. 5
47	532 19 37-04	Tube Upper Bagger
49	532 19 33-05	Bar Spreader Bagger
50	873 80 05-00	Nut Lock Hex w/Insert 5/16-18 unc
51	532 19 99-03	Latch Spring Bagger
53	873 51 04-00	Nut Keps Hex 1/4-20 unc
54	872 14 04-06	Bolt 1/4-20 x 3/5 Gr. 5

NOTE: All component dimensions given in U.S. inches.
1 inch = 25.4 mm.

**TRACTOR - MODEL NO. RE175H107RBK(96061021202), PRODUCT NO. 960 61 02-12
MOWER LIFT**

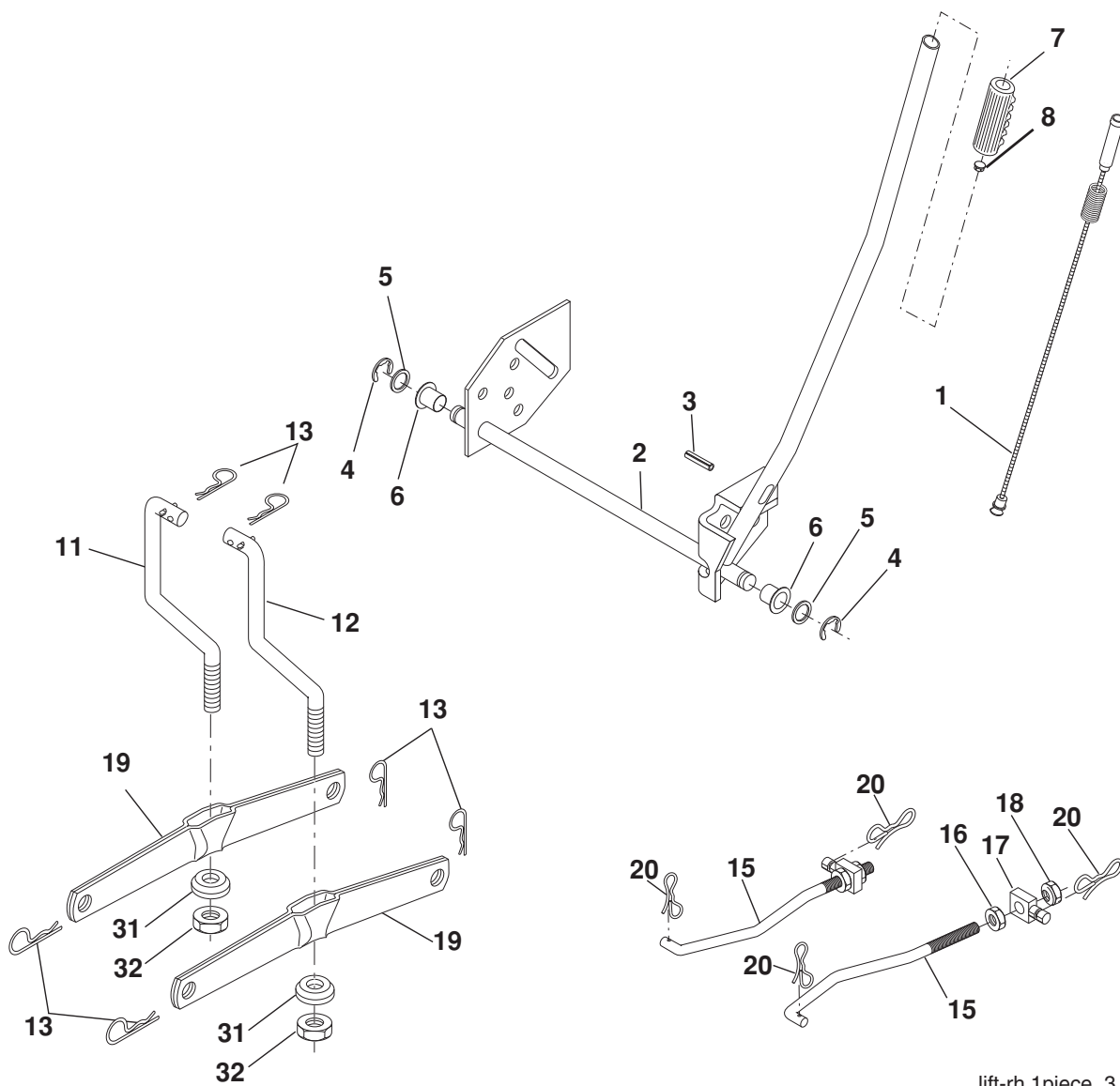

lift-rh.1piece_3

KEY PART NO.	NO.	DESCRIPTION
1	532 40 50-07	Plunger Asm. Lift Lever
2	532 19 80-70	Shaft Asm. Lift
3	532 18 88-22	Pin Groove
4	812 00 00-02	E Ring #5133-62
5	819 21 16-21	Washer 21/32 x 1 x 21 Ga.
6	532 12 01-83	Bearing Nylon
7	532 10 94-13	Grip Handle Bicycle
8	532 12 45-26	Button Plunger Black
11	532 16 58-29	Link Asm Lift LH
12	532 16 58-31	Link Asm Lift RH
13	532 12 46-70	Retainer Spring

KEY PART NO.	NO.	DESCRIPTION
15	532 17 32-88	Link Front
16	873 35 08-00	Nut Jam Hex 1/2-13 unc
17	532 17 56-89	Trunnion
18	873 80 08-00	Nut Lock w/Wsh 1/2-13 unc
19	532 13 98-68	Arm Suspension Mower
20	532 19 42-09	Pin Cotter 7/16 Bowtie Lock
31	532 16 98-65	Bearing, Pvt. Lift
32	873 54 06-00	Nut Crownlock 3/8-24

NOTE: All component dimensions given in U.S. inches
1 inch = 25.4 mm

Rally