

REPAIR PARTS MANUAL
MODEL NO. RELTS3611B
Lawn Tractor

Rally

HOW TO USE THIS MANUAL

This manual is designed to provide the customer with a means to identify the parts on his/her tractor when ordering repair parts. The illustrations may or may not represent the actual assemblies; therefore, it is not recommended to use this manual as a guide to assemble or disassemble the tractor. Some hardware and parts are drawn larger in order to more readily identify them.

Each tractor has its own model number.

The model number for your tractor can be found on the fender under the seat.

When ordering parts, always give the following information:

- Product - "Lawn Tractor"
- Model Number - RELTS3611B
- Part Number
- Part Description

TABLE OF CONTENTS

SCHEMATIC.....	3
ELECTRICAL.....	4-5
CHASSIS AND ENCLOSURES.....	6-7
DRIVE.....	8-9
SEAT.....	10
DECALS.....	11
STEERING WHEEL.....	12-13
ENGINE.....	14
MOWER LIFT.....	15
MOWER DECK.....	16-17

TRACTOR--MODEL NUMBER RELTS3611B

SCHEMATIC

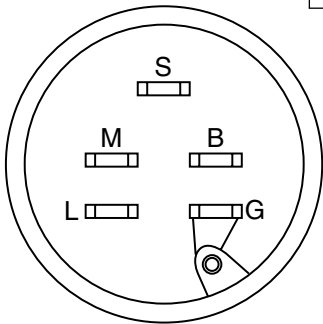
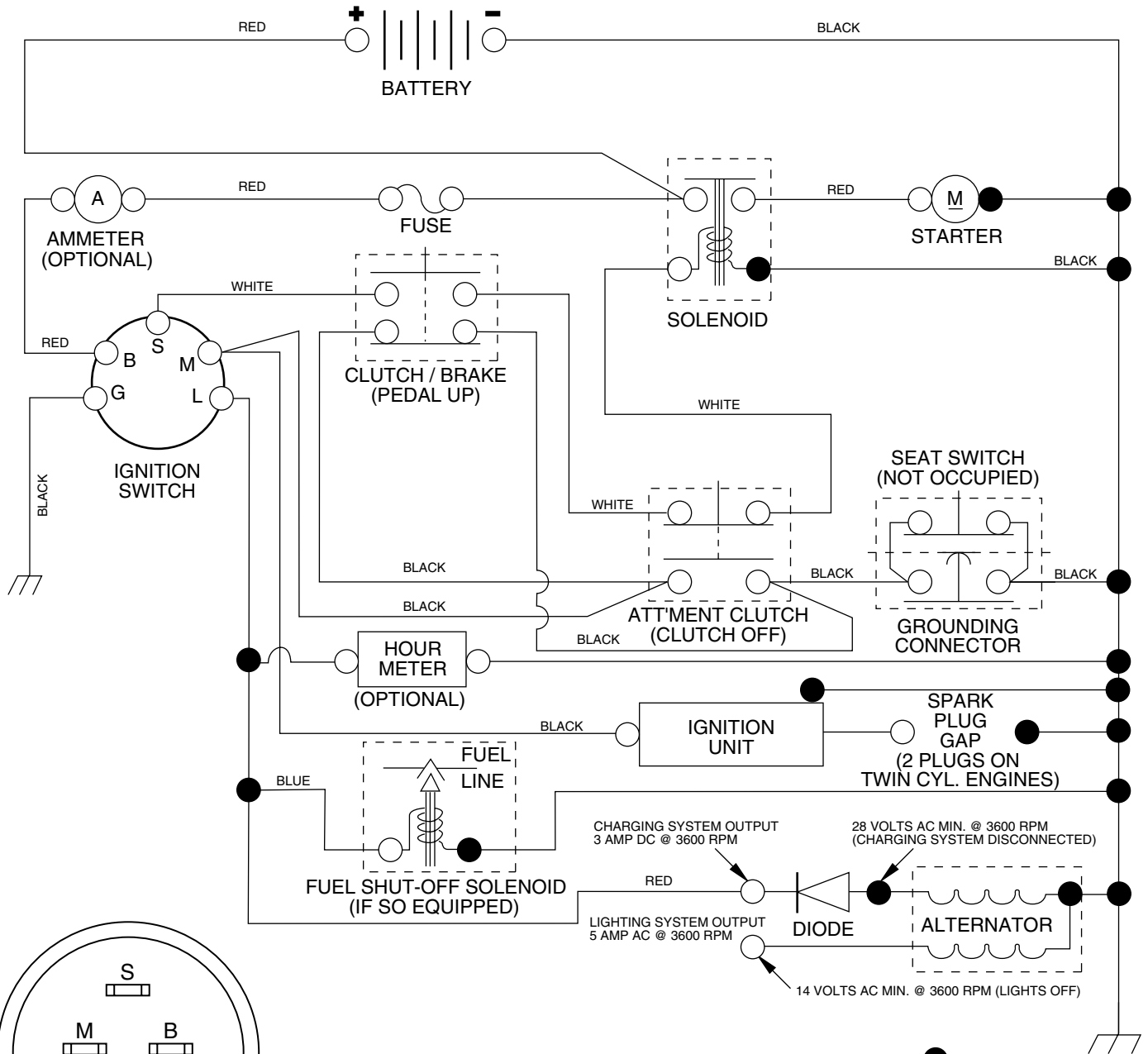

IGNITION SWITCH

POSITION	CIRCUIT
OFF	M + G
ON	B + L
START	B + S + L

WIRING INSULATED CLIPS
NOTE: IF WIRING INSULATED CLIPS WERE REMOVED FOR SERVICING OF UNIT, THEY SHOULD BE REPLACED TO PROPERLY SECURE YOUR WIRING.

●
 NON-REMOVABLE CONNECTIONS

○
 REMOVABLE CONNECTIONS

REPAIR PARTS

TRACTOR--MODELNUMBERRELT3611B

ELECTRICAL

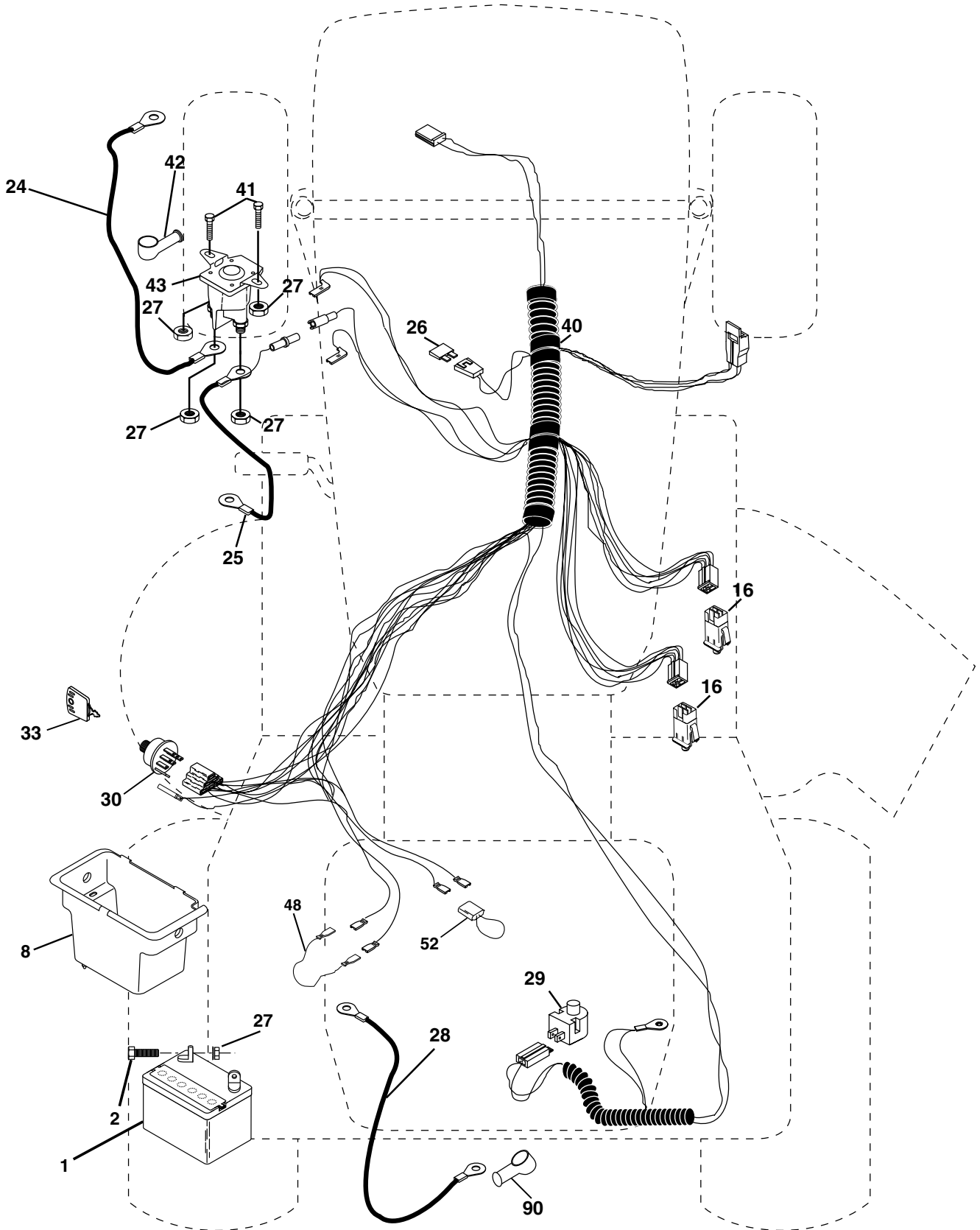

REPAIR PARTS

TRACTOR--MODEL NUMBER RELTS3611B

ELECTRICAL

KEY NO.	PART NO.	DESCRIPTION
1	163465	Battery
2	74760412	Bolt Hex Hd 1/4-20unc X 3/4
8	176889	Box Battery Fender
16	176138	Switch Interlock
24	4799J	Cable Battery
25	146147	Cable Battery 6 Ga 44" red
26	175158	Fuse 20 AMP
27	73510400	Nut Keps Hex 1/4-20 Unc
28	4207J	Cable Ground 6 Ga 12" black
29	121305X	Switch Plunger Nc Gray
30	175567	Switch Ign
33	140401	Key Ign
40	179730	Harness Ignition
41	71110408	Bolt Blk Fin Hex 1/4 - 20 x 1/2
42	131563	Cover Terminal Red
43	178861	Solenoid
48	140844	Adapter Ammeter
52	141940	Protection Wire Loop
90	180449	Cover Terminal Battery

NOTE: All component dimensions give in U.S. inches
1 inch = 25.4 mm.

REPAIR PARTS

TRACTOR--MODELNUMBERRELT3611B

CHASSIS AND ENCLOSURES

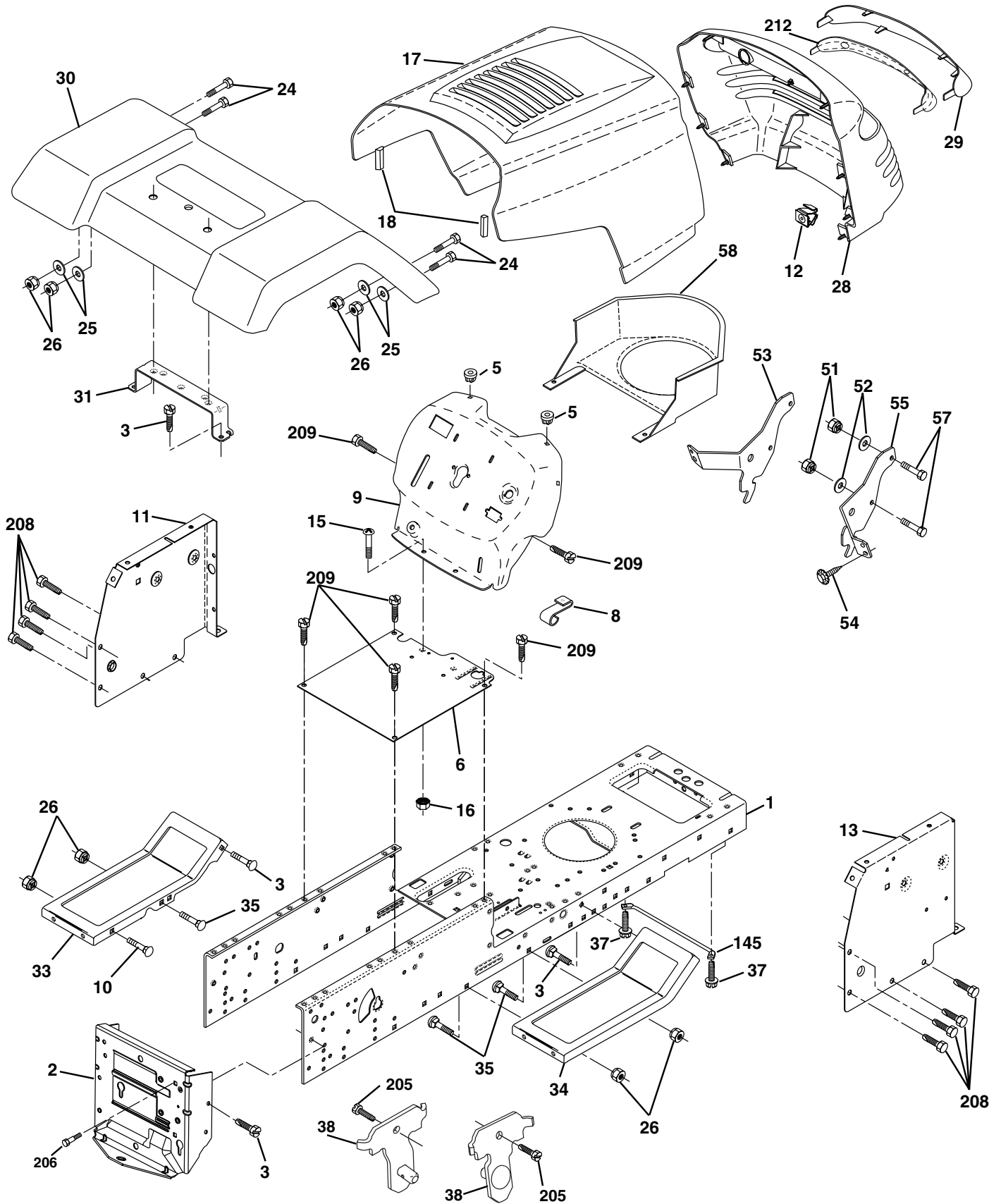

REPAIR PARTS

TRACTOR--MODEL NUMBER RELTS3611B

CHASSIS AND ENCLOSURES

KEY NO.	PART NO.	DESCRIPTION
1	174620	Chassis
2	176554	Drawbar
3	17060612	Screw 3/8-16 x 3/4
5	155272	Bumper Hood/Dash
6	174643X012	Saddle
8	155138	Clip, Retainer Slide-On
9	168347X011	Dash
10	72140608	Bolt, Carriage 3/8-16 x 1
11	174996	Dashboard, panel LH
12	145660	Clip Tinnerman Grille P/L
13	172105X010	Dashboard, panel RH
15	74180512	Machine screw 5/16-18 unc x 3/4
16	73510500	Nut, Keps 5/16-18 Unc
17	159639X505	Hood Pnt Stil P/L w/Trim 505
18	126938X	Bumper Hood
24	74780616	Bolt, Hex Head, Fin. 3/8-16 x 1 Grade 5
25	19131312	Washer 13/32 x 13/16 x 12 Gauge
26	73800600	Nut Lock Hex w/Ins. 3/8-16 Unc
28	179103	Grille/Lens Asm.
29	140273X428	Lens
30	169465X505	Fender
31	136619	Fender Bracket
33	179716X505	Footrest, LH
34	179717X505	Footrest, RH
35	72110606	Bolt 3/8-16 X 3/4
37	17490508	Screw Thdrol 5/16-18 x 1/2
38	175710	Bracket Asm. Pivot Mower Rear
51	73800400	Nut Lock, w/Insert 14/20 UNC
52	19091416	Washer 9/32 x 7/8 x 16 Ga.
53	144697	Bracket Grille
54	161464	Screw Hex WsHd 8-18 x 7/8
55	144696	Bracket Grille RH
57	74780412	Bolt FinHex 1/4-20 UNC x .75
58	150127	Duct Air Engine P/L LT
145	156524	Rod Pivot Chassis/Hood
205	17490608	Screw Thdrol 3/8-16 x 1/2
206	170165	Bolt Shoulder 5/16-18 TT
208	17670608	Screw Thdrol 3/8-16 x 1/2
209	17000612	Screw Hexwsh Thdr 3/8-16 x 3/4
212	156229	Insert Lens Reflect
--	5479J	Button Plug

NOTE: All component dimensions given in U.S. inches
1 inch = 25.4 mm

REPAIR PARTS

TRACTOR--MODEL NUMBER RELTS3611B

DRIVE

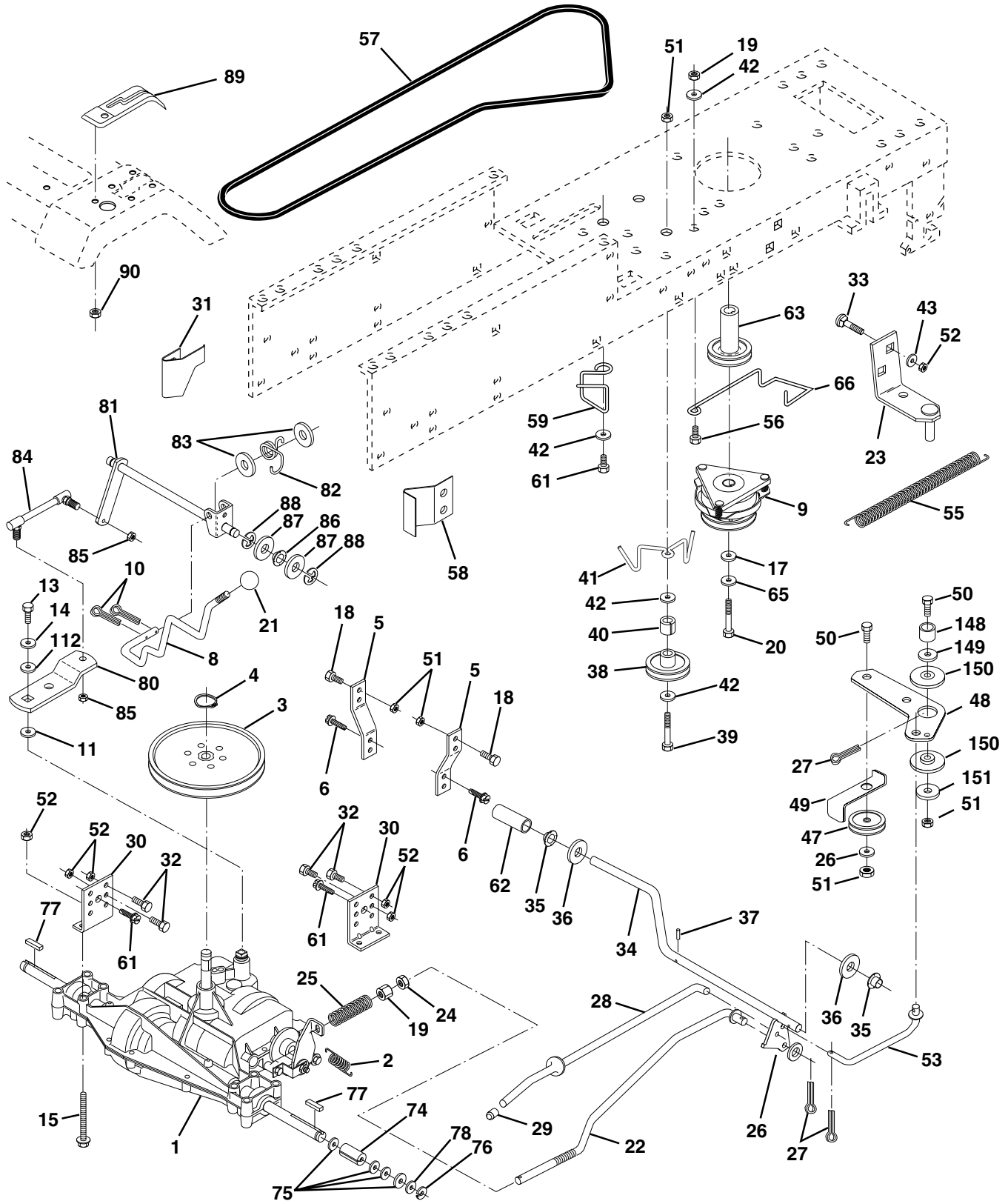

REPAIR PARTS

TRACTOR--MODEL NUMBER RELTS3611B

DRIVE

KEY NO.	PART NO.	DESCRIPTION	KEY NO.	PART NO.	DESCRIPTION
1	-----	Transaxle Peerless, Model 204-506B (Order parts from transaxle manufacturer)	51	73680600	Nut, Crownlock 3/8-16
2	146682	Spring, Brake Return	52	73680500	Nut, Crownlock 5/16-18
3	123666X	Pulley, Transaxle	53	105710X	Link, Clutch
4	1200028	Ring, Retainer	55	105709X	Spring, Return, Clutch
5	121520X	Strap, Torque	56	74760620	Bolt, Fin, Hex 3/8-16unc x 1-1/2
6	17060512	Screw, 5/16-18 x 3/4 SMGML	57	130801	V-Belt, Drive
7	162240	Bracket, T/A, Saddle Shift	59	169691	Keeper Belt Center Span
8	131679	Rod, Shifter	61	17120614	Screw, 3/8-16 x .875 SMGML
10	76020416	Pin, Cotter 1/8 x 1	62	8156H	Cover, Foot Pedal
11	105701X	Washer, Shift Plate	63	180219	Pulley, Engine
12	19151216	Washer 15/32 x 3/4 x 16	64	71170764	Bolt, Hex 7/16-20 x 4 Gr. 5
13	74550412	Bolt 1/4-28 UNF Gr. 8 w/Patch	65	10040700	Washer, Lock Hvy Hlcl Spr 7/16
14	10040400	Washer Lock	66	154778	Keeper, Belt Engine F-Proof
18	74780616	Bolt, Fin Hex 3/8-16 Unc x 1 Gr. 5	70	180218	Guide Belt Mower Drive RH
19	73800600	Locknut 3/8-16	74	137057	Spacer, Split
21	106933X	Knob	75	121749X	Washer 25/32 x 1-1/4 x 16 Ga.
22	130804	Rod, Brake	76	12000001	E-Ring
24	73350600	Nut, Hex Jam 3/8-16	77	123583X	Key Square
25	106888X	Spring, Rod, Brake	78	121748X	Washer 25/32 x 1-5/8 x 16 Ga.
26	19131316	Washer 13/32 x 13/16 x 16 Gauge	79	2228M	Key Woodruff #9 3/16 x 3/4
27	76020412	Pin, Cotter 1/8 x 3/4	96	4497H	Retainer Spring 1" Ziinc/Cad
28	175765	Rod, Brake, Park	112	19091210	Washer 9/32 x 3/4 x 10 Ga.
29	71673	Cap, Plunger	113	127285X	Strap Torque L.H. Lt
30	174973	Bracket, Transaxle	116	72140608	Bolt, RdHd Sq Neck 3/8-16 x 1.00
32	74760512	Bolt Hex Hd 5/16-18 UNC x 3/4	120	73900600	Nut Lock Flg. 3/8-16
34	175578	Shaft, Foot Pedal	145	74490540	Bolt, Hex Flghd 5/16-18 Gr. 5
35	120183X	Bearing Nylon	150	175456	Bushing, Bellcrank Grd Dr.
36	19211616	Washer 21/32 x 1 x 16 Gauge	151	19133210	Washer 13/32 x 2 x 10 Ga.
37	1572H	Pin, Roll 3/16 x 1	170	178394	Keeper, Belt, Transaxle
38	179114	Pulley Idler	202	72110614	Bolt Carr Sh 3/8-16 x 1-3/4 Gr. 5
39	74760648	Bolt Fin Hex 3/8-16 Unc x 3	212	145212	Nut Hex Flange Lock
41	175556	Keeper, Belt	250	17060612	Screw 3/8-16 x 3/4
47	127783	Pulley, Idler			
48	154407	Bellcrank Asm Clutch			
49	123205X	Retainer, Belt			
50	74760624	Bolt, Hex 3/8-16 x 1-1/2			

NOTE: All component dimensions give in U.S. inches.
1 inch = 25.4 mm.

REPAIR PARTS

TRACTOR--MODELNUMBERRELT3611B

SEAT

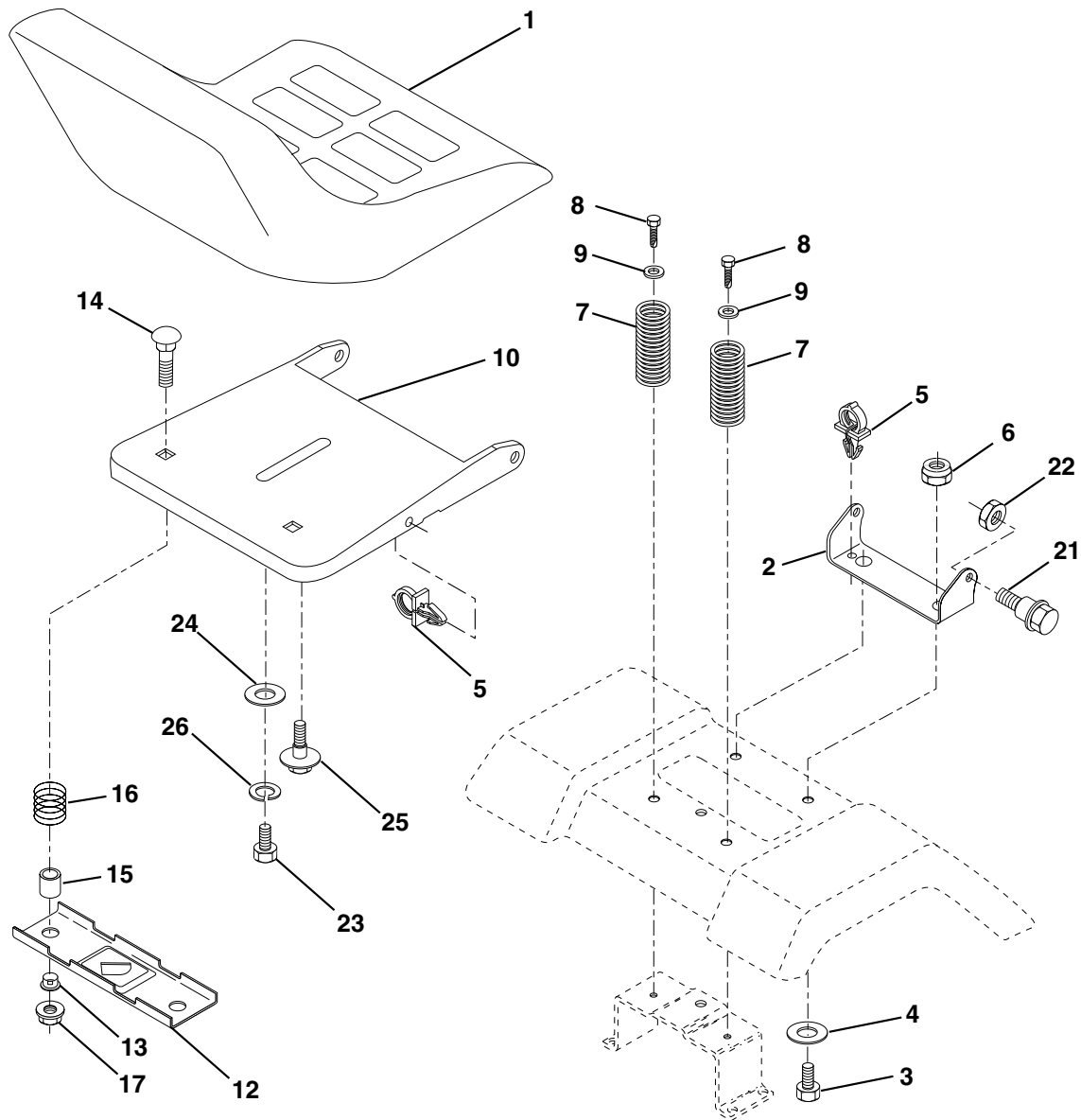

KEY NO.	PART NO.	DESCRIPTION
1	175389	Seat
2	140551	Bracket, Pivot, Seat
3	71110616	Fin Hex 3/8-16unc x 1
4	19131610	Washer 13/32 x 1 x 10 Ga.
5	145006	Clip, Push-in
6	73800600	Nut
7	124181X	Spring, Seat
8	17000616	Screw, 3/8-16 x 1.5 SMGML Tap/R
9	19131614	Washer 13/32 x 1 x 14 Ga.
10	174894	Pan, Seat
12	121246X	Bracket, Mounting, Switch, Seat
13	121248X	Bushing, Nylon

KEY NO.	PART NO.	DESCRIPTION
14	72050412	Nut, Crownlock 1/4-20 x 1-3/8
15	134300	Spacer, Split
16	121250X	Spring
17	123976X	Nut, Lock, Flange 1/4 Gr. 5
21	171852	Bolt, Shoulder 5/16-18 UNC-2A
22	73800500	Nut
23	71110814	Bolt Hex Black
24	19171912	Washer 17/32 x 1-3/16 x 12 Ga.
25	127018X	Bolt Shoulder 5/16-18 x .62
26	10040800	Washer Lock Hvy Hclc Spr 1/2

NOTE: All component dimensions given in U.S. inches
1 inch = 25.4 mm

REPAIR PARTS

TRACTOR--MODEL NUMBER RELTS3611B

DECALS

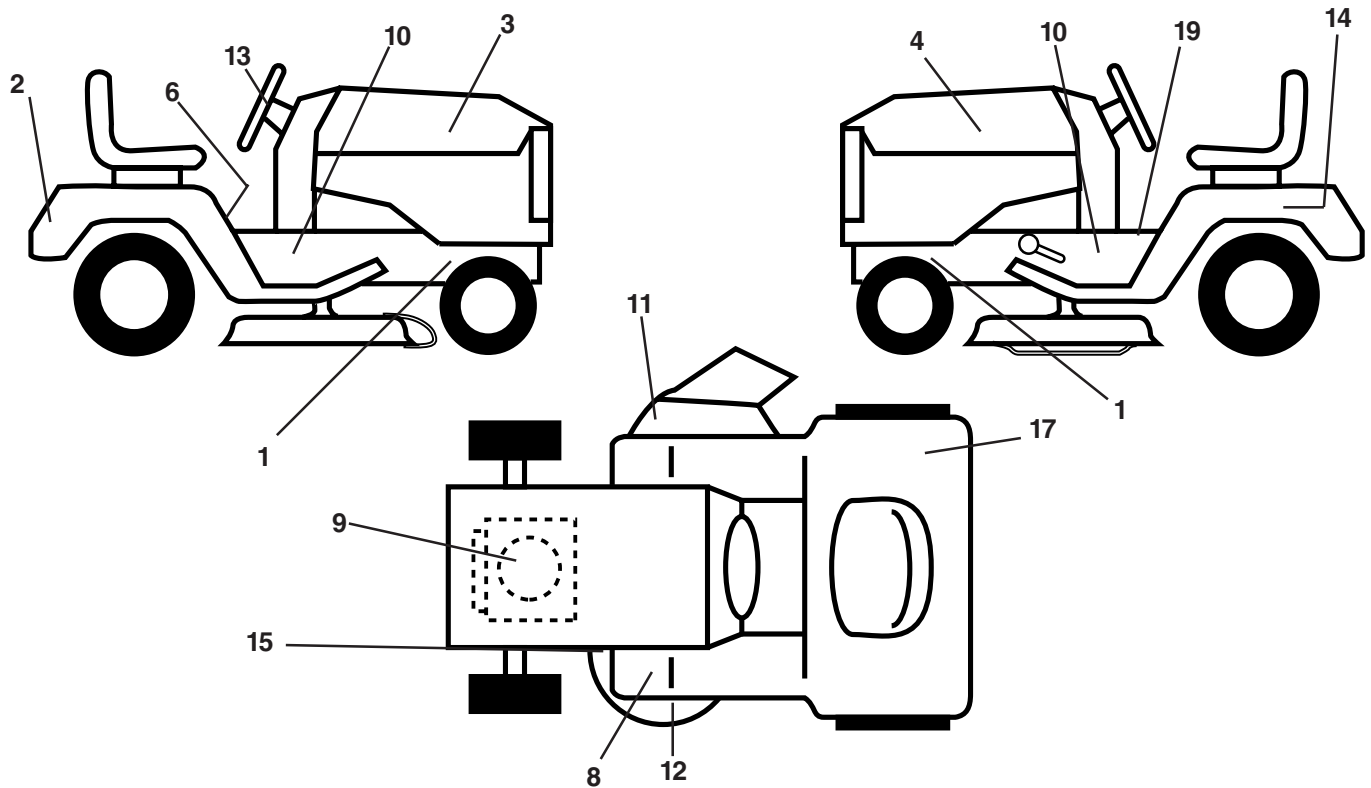

KEY NO.	PART NO.	DESCRIPTION	KEY NO.	PART NO.	DESCRIPTION
1	159736	Decal, Chassis Hot Muffler	13	127075	Decal Wheel Steering
2	181146	Decal, Fender Logo	14	145005	Decal, Battery Dan/Poi P/L Symbols
3	181144	Decal, Hood Rh	15	136832	Decal, V-Belt
4	181145	Decal, Hood Lh	17	180432	Decal, 100 DBA/CE
6	145498	Decal, Read Owner's Manual Syms	19	140837	Decal, Parking Brake
8	159737	Decal, Brake/Clutch Symbol LT	--	138311	Decal, Handle, Lift, Height Adjust (Lift Handle)
9	170843	Decal, HP Engine	--	162598	Decal, Drawbar Load Limit
10	181192	Decal Chassis	--	181436	Manual, Operator's (European)
11	182166	Decal, Mower Cutfinger Symbol	--	178947	Manual, Repair Parts
12	134999	Decal, Enviro Deck White			

TIRES AND WHEELS

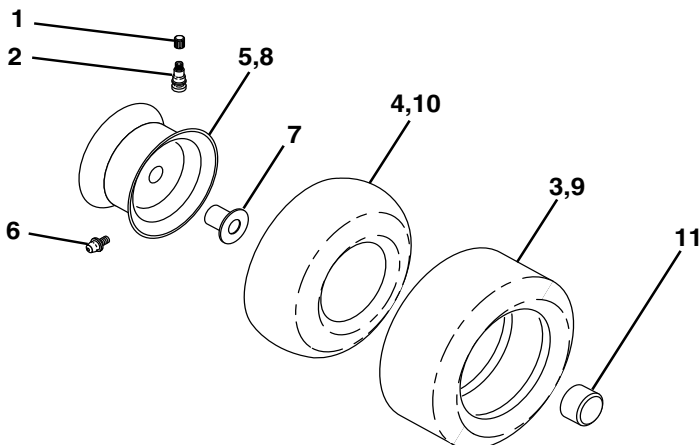

KEY NO.	PART NO.	DESCRIPTION
1	59192	Cap, Valve
2	65139	Stem, Valve
3	124157X	Tire Front
4	59904	Tube, Front (not furnished)
5	106732X427	Rim, Asm. Front
6	278H	Grease Fitting (rear tire only)
7	9040H	Bearing, Flange (front tire only)
8	106108X427	Rim, Asm. Rear
9	123969X	Tire, Rear
10	7152J	Tube, Rear (not furnished)
11	104757X428	Cap, Axle
--	144334	Sealant, Tire (10 oz. Tube)

NOTE: All component dimensions given in U.S. inches
1 inch = 25.4 mm

REPAIR PARTS

TRACTOR--MODELNUMBERRELT3611B

STEERING WHEEL

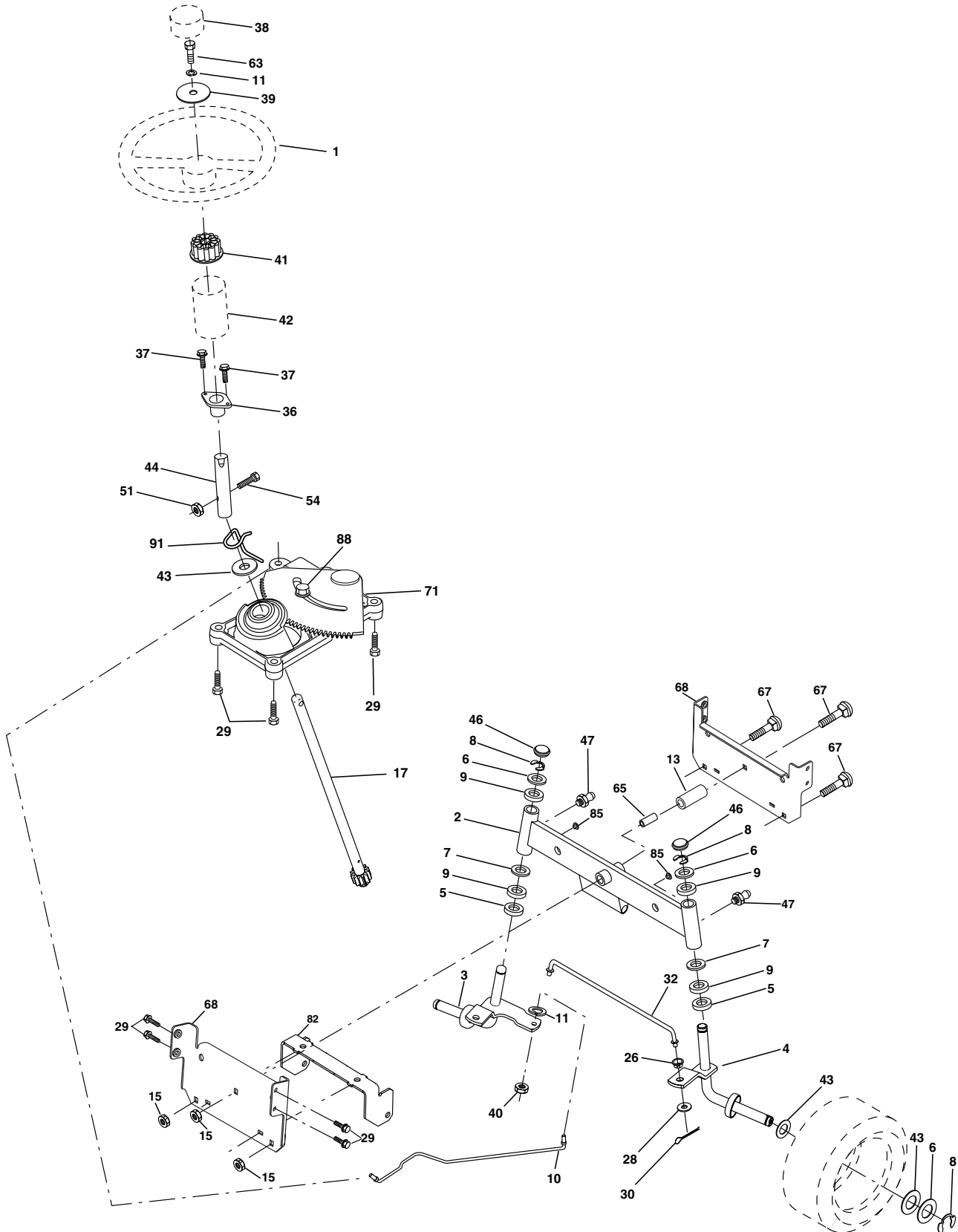

REPAIR PARTS

TRACTOR--MODEL NUMBER RELTS3611B

STEERING WHEEL

KEY NO.	PART NO.	DESCRIPTION
1	133741X428	Wheel Steering
2	175131	Axle Asm Front
3	169840	Spindle Asm LH
4	169839	Spindle Asm RH
5	6266H	Bearing, Race, Thrust Hardened
6	121748X	Washer 25/32 X 1-5/8 X 16 Ga
7	19272016	Washer 27/32 X 1-1/4 X 16 Ga
8	12000029	Ring Klip
9	3366R	Bearing
10	175121	Link Drag
11	10040600	Washer Lock Hvy Hlcl Spr 3/8
13	163518	Spacer Brg. Axle Front
15	145212	Nut Hexflange Lock
17	177876	Steering, Assembly Shaft
26	126847X	Bushing Link Drag Blk Lr
28	19131416	Washer 13/32 x 7/8 x 16 Ga.
29	17060612	Screw 3/8-16x3/4 SMGML Tap/R
30	76020412	Pin Cotter 1/8 x 3/4 CAD
32	130465	Rod Connecting
36	155099	Bushing Steering
37	152927	Screw TT #10-32 X 5 x 3/8 Flange
38	133742X428	Cap Wheel Steering
39	19133812	Washer 13/32 x 2-3/8 x 12 Ga
40	7810H	Nut Lock Center 3/8-24 Unf
41	100711L	Adapter Wheel Strg
42	145054X428	Boot Steering
43	121749X	Washer 25/32 X 1 1/4 X 16 Ga
44	153720	Extension Steering
46	121232X	Cap Spindle
47	6855M	Fitting Grease
51	73800500	Nut Lock Hex W/Ins. 5/16-18 Unc P
54	74780520	Bolt Fin Hex 5/16-18 Unc 6 x 1-1/4
63	74780616	Bolt Fin Hex 3/8-16unc x 1 Gr. 5
65	160367	Spacer Brace Axle
67	72140618	Bolt RDHD SQ 3/8-16UNC x 2-1/4
68	169827	Brace Axle
71	175146	Steering Asm
82	169835	Bracket Susp. Chassis Front
85	133835	Fastener Christmas Tree
88	175118	Bolt Shoulder 7/16-20unc
91	175553	Clip Steering

NOTE: All component dimensions given in U.S. inches
1 inch = 25.4 mm

REPAIR PARTS

TRACTOR--MODEL NUMBER RELTS3611B

ENGINE

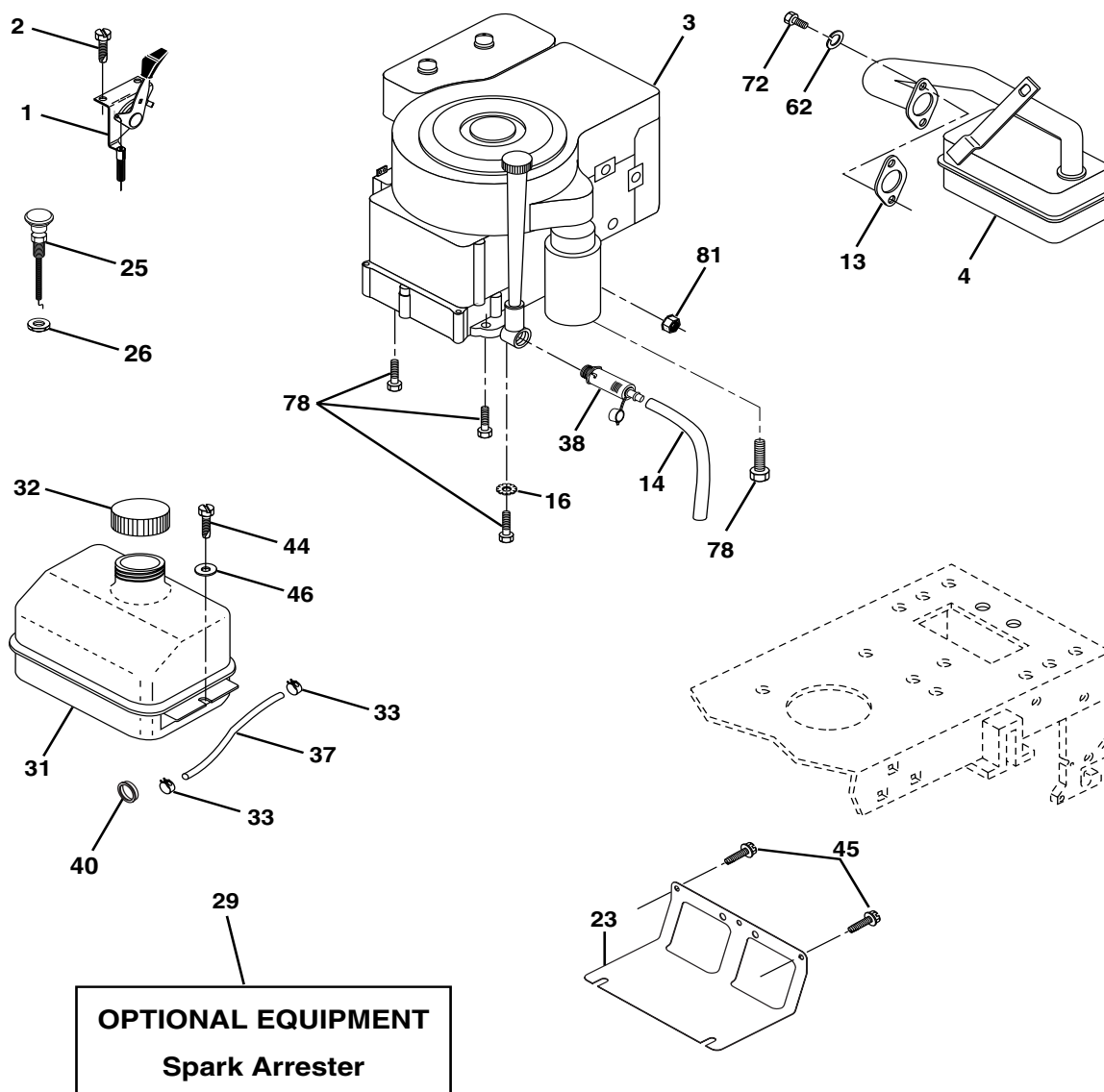

OPTIONAL EQUIPMENT
Spark Arrester

KEY NO.	PART NO.	DESCRIPTION
1	170551	Control Th/ch
2	17720408	Screw Hex Thd Cut 1/4-20x1/2
3	-----	Engine Briggs Model 289707 (Order parts from engine manufacturer)
4	137348	Muffler LT
13	165291	Gasket Eng 1 313 Id Tin Plated
14	148456	Drain Oil Tube Easy
16	11050600	Washer Lock Ext Tooth 3/8
23	169837	Shield Brn/Dbr Guard
25	180945	Control Choke
26	73920600	Nut Keps 3/8-24 Unf
29	137180	Kit Spark Arrestor (Flat Scrn)
31	109202X	Tank Fuel Front 2 00

KEY NO.	PART NO.	DESCRIPTION
32	140527	Cap Asm Fuel
33	123487X	Clamp Hose Blk
37	137040	Line Fuel
38	148315	Plug Drain Oil Easy
40	124028X	Bushing Snap Nyl Blk Fuel Line
44	17670412	Screw Hexwsh Thdrol 1/4-20x3/4
45	17000612	Screw Hex Wsh Thdr 3/8-16 x 3/4
46	19091416	Washer 9/32 X 7/8 X 16 Ga
62	10040500	Washer 5/16
72	71070512	Screw Hex Hd Cap 5/16-18 x 3/4
78	17060620	Screw 3/8-16x1-1/4
81	73510400	Nut Keps Hex 1/4-20 Unc

NOTE: All component dimensions given in U.S. inches.
1 inch = 25.4 mm.

REPAIR PARTS

TRACTOR--MODEL NUMBER RELTS3611B

MOWER LIFT

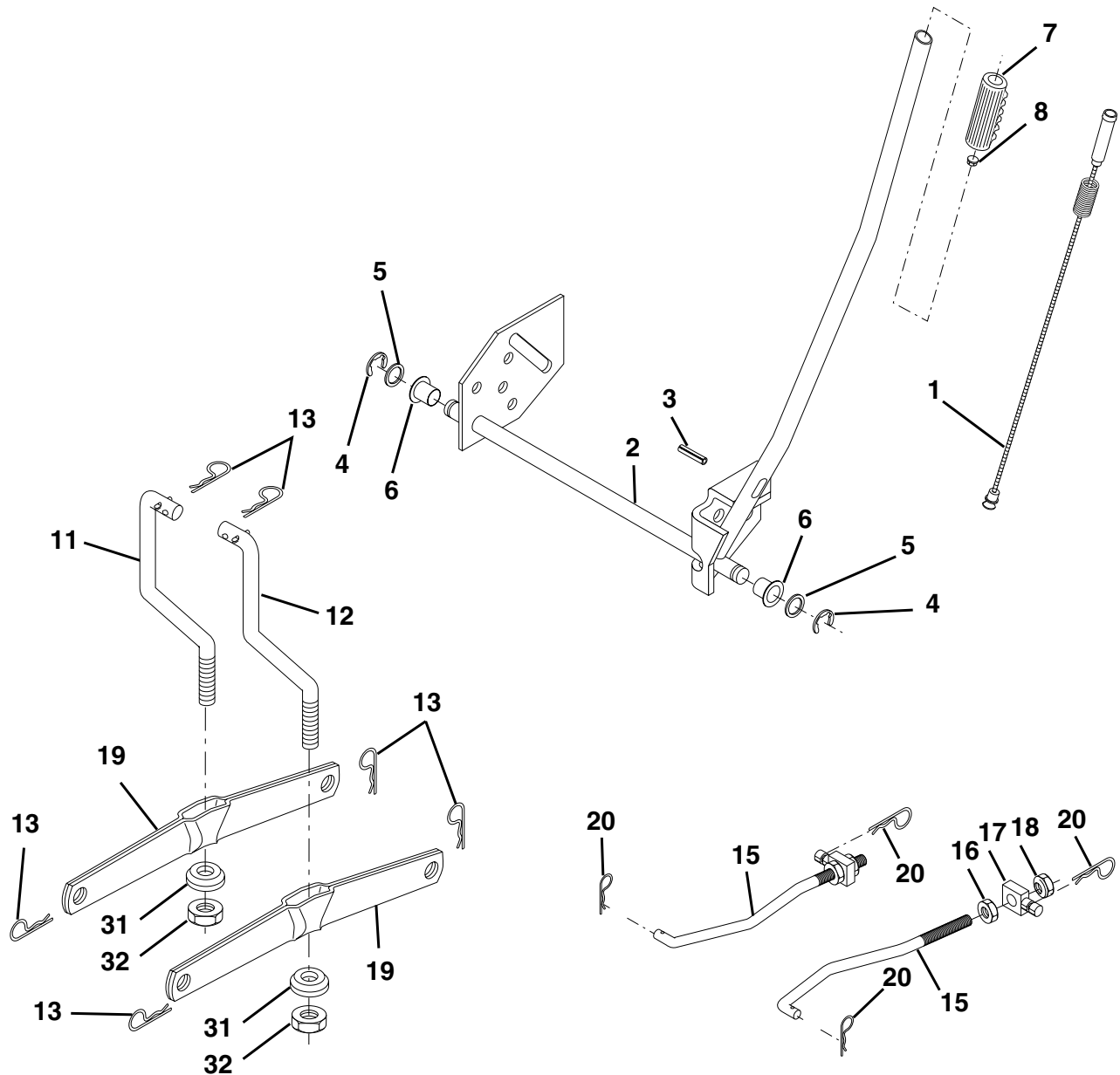

KEY NO.	PART NO.	DESCRIPTION
1	159460	Asm. Inner Wire w/Plunger
2	159471	Asm., Shaft, Lift
3	105767X	Pin, Groove
4	12000002	Ring, E #5133-62
5	19211621	Washer 21/32 x 1 x 21 Ga.
6	120183X	Bearing, Nylon
7	109413X	Grip Handle Bicycle Matte Blk
8	124526X	Button, Plunger
11	139865	Link, Lift, Lh
12	139866	Link, Lift, Rh
13	4939M	Spring, Retainer

KEY NO.	PART NO.	DESCRIPTION
15	173288	Link, Front
16	73350800	Nut, Jam, Hex 1/2-13 Unc
17	130171	Trunnion
18	73800800	Nut Lock w/wsh 1/2-13 Unc
19	139868	Arm, Suspension, Rear
20	163552	Spring, Retainer
31	169865	Bearing, Pvt Lft
32	73540600	Nut Crownlock 3/8-24

NOTE: All component dimensions given in U.S. inches
1 inch = 25.4 mm

REPAIR PARTS

TRACTOR--MODELNUMBERRELT3611B

MOWER DECK

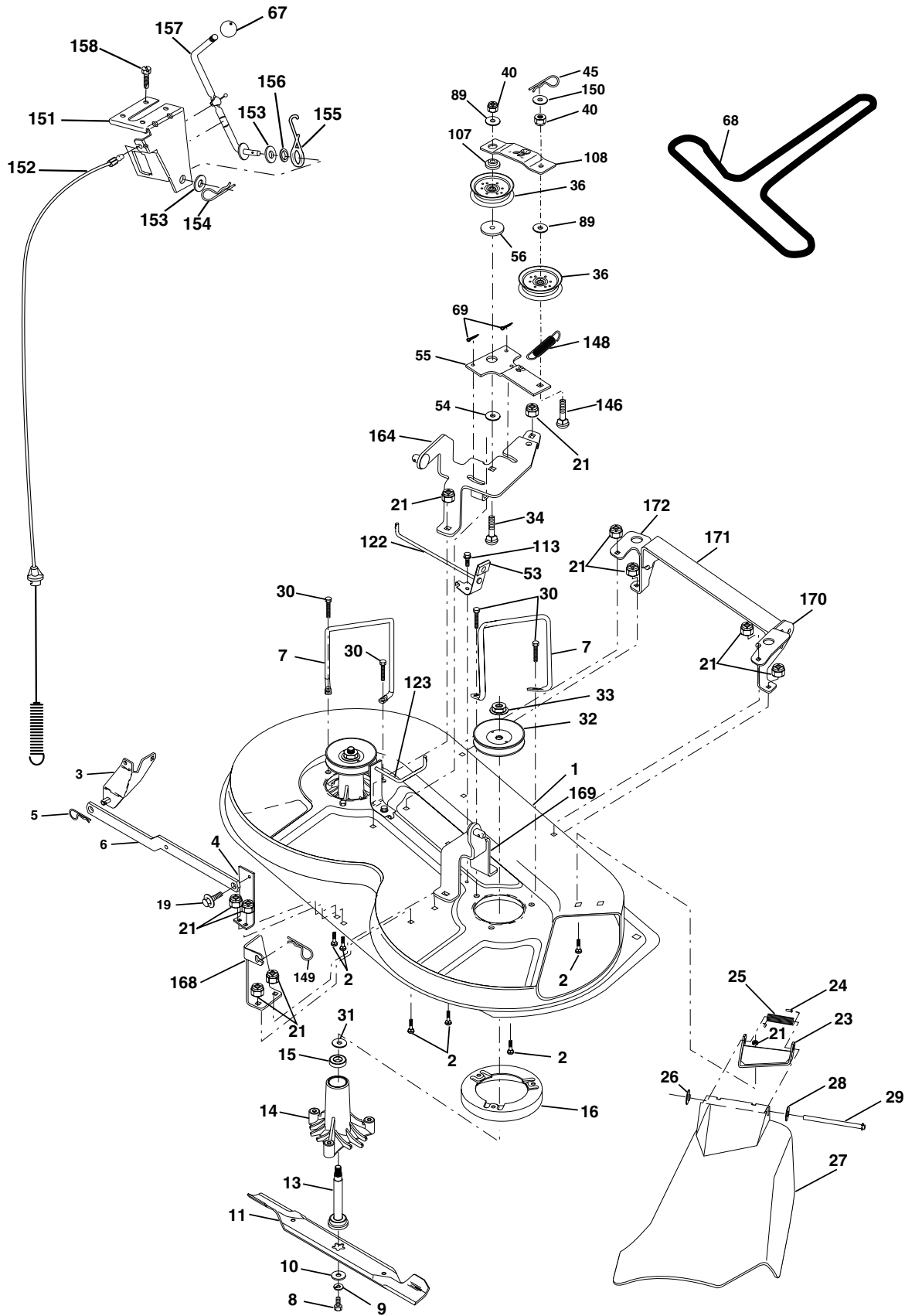

REPAIR PARTS

TRACTOR--MODEL NUMBER RELTS3611B

MOWER DECK

KEY NO.	PART NO.	DESCRIPTION	KEY NO.	PART NO.	DESCRIPTION
1	174595	Deck Asm Weldment	56	165723	Spacer, Retainer
2	72140506	Bolt	67	106932X	Knob Rd 3/8-16 Plstc Thds Blk
3	138017	Asm., Bar, Anti-Sway	68	180213	V-Belt, Mower
4	175654	Bracket Sway Bar 36"	69	76020312	Pin, Cotter 3/32 x 3/4
5	4939M	Spring, Retainer	89	19131612	Washer 13/32 x 1 x 12 Ga.
6	178024	Bar Sway Deck	107	133502	Spacer, Retainer
7	140608	Keeper Belt Lh	108	133503	Stiffener, Idler Arm
8	850857	Bolt 3/8-24 x 1.25 Gr. 8	113	17490508	Screw Thdrol 5/16-18 x 1/2
9	10030600	Washer, Lock	122	174505	Rod, Brake, LH
10	140296	Washer, Hardened	123	174504	Rod, Brake, RH
11	138496	Blade, Mower, Hi Lift	146	165891	Bolt Carriage Idler
13	137645	Asm., Shaft, Mandrel, Vented	148	169022	Spring Return Idler
14	128774	Housing, Mandrel, Vented	149	165898	Retainer Spring Yellow Zinc
15	110485X	Bearing, Ball, Mandrel	150	19091216	Washer 9/32 x 3/4 x 16 Ga.
16	174493	Stripper, Mower	151	169670	Bracket Clutch Cable
19	132827	Bolt, Shoulder	152	176079	Clutch Cable 38"/42"
21	73680500	Nut, Crownlock 5/16 - 18 UNC	153	169674	Washer Flat 3/8" Type B
23	136631	Bracket, Deflector	154	169675	Spring Retainer
24	105304X	Cap, Sleeve	155	169671	Spring Retention Lvr Cltch Cab
25	123713X	Spring, Torsion, Deflector	156	169672	Spacer Clutch Cable 3/8"
26	110452X	Washer, Lock	157	169669	Rod Clutch Cable 3/8"
27	175029X428	Deflector, Shield	158	17720408	Screw Hex Thd Cut 1/4-20 x 1/2
28	19111016	Washer 11/32 x 5/8 x 16 Ga.	164	174976	Bracket Asm Support Susp 36"
29	121980X	Rod, Hinge	168	172377	Bracket Deck Cable 36"
30	173984	Screw Hex Thdrol	169	174977	Bracket Asm Suspension
31	129963	Washer, Spacer	170	172359	Bracket Suspension RF
32	153531	Pulley, Mandrel	171	165237	Brace Support Susp Frt
33	178342	Nut Flange Top Lock	172	172355	Brace Suspension LF
34	72110614	Bolt Rdhd 3/8-16 x 1-3/4	--	130794	Mandrel Assembly(Includes Housing, Shaft and Shaft Hardware Only - Pulley Not Included)
36	131494	Pulley, Idler, Flat	--	181376	Replacement Mower, Complete
40	73680600	Nut, Crownlock 3/8 - 16 UNC			
45	4497H	Retainer Spring 1: Zinc/Cad			
53	130840	Brake Assembly			
54	133943	Washer, Hardened			
55	133840	Arm, Idler Assembly			

NOTE: All component dimensions given in U.S. inches
1 inch = 25.4 mm



SERVICE POLICY WARRANTY



Issued January 1980
Revised January 1991

LIMITED WARRANTIES FOR NEW PEERLESS GEAR POWER TRAIN COMPONENTS

A. Products Warranted

Peerless Gear and Machine Division of Tecumseh Products Company ("Tecumseh"), subject to the limitations contained below, will, at its option, repair or replace, without charge for parts or labor only, any part of a new Power Train Component (which as used herein means and includes the transaxle, gear box, transmission, differential and right angle drives, and any part of the Power Train Component), EXCEPT any new Power Train Component incorporated in equipment used for commercial or rental purposes, which is found upon examination by any Tecumseh Authorized Service Outlet or by Tecumseh's factory in Grafton, Wisconsin, to be DEFECTIVE IN MATERIAL AND/OR WORKMANSHIP if received by Tecumseh or a Tecumseh Authorized Service Outlet for such examination within TWO YEARS from the date of sale to the original consumer purchaser of Peerless Series 820, 900, 910, 915, 920, 930 transaxles and Series 1100 angle drive and ONE YEAR for all other Peerless products. New Power Train Components incorporated in equipment used for commercial purposes are warranted in the same manner and to the same extent EXCEPT such Power Train Components are warranted for NINETY (90) DAYS ONLY, and must be received by Tecumseh or by a Tecumseh Authorized Service Outlet for such examination within 90 days from the date of sale to the original purchaser. New Power Train Components Incorporated in equipment used for rental purposes are warranted in the same manner and to the same extent EXCEPT such Power Train Components are warranted for THIRTY (30) DAYS ONLY, and must be received by Tecumseh or a Tecumseh Authorized Service Outlet within 30 days from the date of sale to the original purchaser.

B. Products And Items Not Warranted

1. Alterations or Modifications of Power Train Components.
2. Accidents, Normal Maintenance, Failure to follow the Original Equipment Manufacturer's Manual.

This warranty covers only parts of new Power Train Components which are found upon examination to be defective in material or workmanship as delivered to the original purchaser. This warranty does not cover defects caused by depreciation or damage caused by normal wear, accidents, improper maintenance, improper use or abuse of the product, failure to follow the instructions contained in an Instruction Manual for the operation of the Power Train Component and parts. The cost of normal maintenance and replacement of service items which are not defective shall be paid for by the original purchaser.

C. Securing Warranty Service

Warranty service can be arranged for by contacting either a Tecumseh Authorized Service Outlet (any Tecumseh Registered Service Dealer, Tecumseh Authorized Service Distributor, or Tecumseh Central Warehouse Distributor) or by contacting Tecumseh, c/o Service Manager, Engine and Transmission Group Service Division, 900 North Street, Grafton, Wisconsin 53024. Warranty service can only be performed by a Tecumseh Authorized Service Outlet or by Tecumseh at its factory in Grafton, Wisconsin. At the time of requesting warranty service, evidence must be presented of the date of sale to the original purchaser. The purchaser shall pay any charges for making service calls and/or for transporting the product to and from the place where the inspection and/or warranty work is performed. The purchaser shall be responsible for any damage or loss incurred in connection with the transportation of Power Train Components and/or part(s) of the Power Train Components submitted for inspection and/or warranty work.

D. Limitation of Damages and Implied Warranties

The foregoing EXPRESSED WARRANTY IS IN LIEU OF ALL OTHER EXPRESS WARRANTIES. Neither Tecumseh nor any of its affiliates makes any warranties, representations or promises, written or oral, as to the quality of the Power Train Component or any of its parts, other than as set forth herein.

ANY IMPLIED WARRANTY OF MERCHANTABILITY OR FITNESS FOR A PARTICULAR PURPOSE, TO THE EXTENT THAT EITHER MAY APPLY TO ANY PART(S) OF POWER TRAIN COMPONENTS, SHALL BE LIMITED IN DURATION TO THE PERIODS OF THE EXPRESSED WARRANTIES DEFINED IN PARAGRAPH A HEREOF. IN NO EVENT WILL TECUMSEH BE LIABLE FOR ANY INCIDENTAL, CONSEQUENTIAL OR SPECIAL DAMAGES AND/OR EXPENSES. Some states do not allow limitations on how long an implied warranty lasts or the exclusion or limitation of incidental or consequential damages, so the above limitation(s) or exclusion(s) may not apply to you. This warranty gives you specific legal rights and you may also have other legal rights which vary from state to state.

E. No Dealer Warranty

Tecumseh neither assumes nor authorizes any other person, natural or corporate, to assume for Tecumseh any other obligations or liabilities in connection with or with respect to any part(s) of a Power Train Component. The seller or dealer of part(s) of a Power Train Component has no authority, whatsoever, to make any representations or promises on behalf of Tecumseh or to modify the terms or limitations of Tecumseh's warranty in any way.

Rally