

REPAIR PARTS MANUAL
MODEL NO. RYX820M
5.0 HP 17 Inch
Tiller

Rally

REPAIR PARTS

TILLER - - MODEL NUMBER RYX820M

HANDLE ASSEMBLY

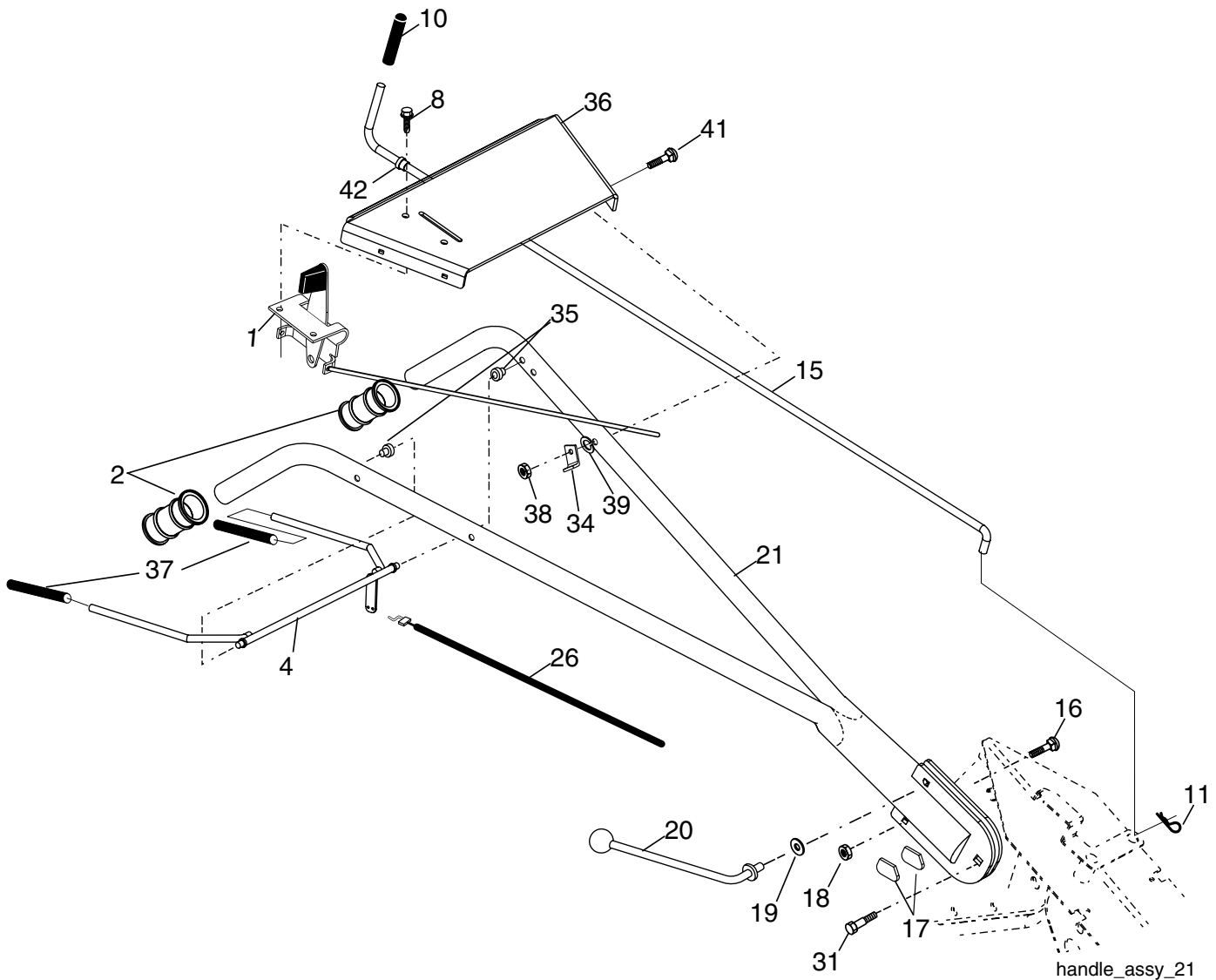

KEY NO.	PART NO.	DESCRIPTION
1	532 18 06-34	Control, Throttle
2	532 15 07-44	Grip, Handle
4	532 15 92-27	Bar, Control
8	817 72 04-08	Screw 1/4-20 x 1/2
10	532 00 83-89	Grip, Handle
11	532 12 47-88	Clip, Hairpin
15	532 10 82-81	Rod, Shift
16	872 11 06-08	Bolt, Carriage 3/8-16 x 1 Gr. 5
17	532 10 92-29	Lock, Handle
18	873 68 06-00	Nut Crownlock 3/8-16 unc
19	819 13 16-11	Washer 13/32 x 1 x 11 Ga.
20	532 10 92-28	Lever, Lock, Handle
21	532 15 02-17	Handle

KEY NO.	PART NO.	DESCRIPTION
26	532 15 92-32	Cable, Clutch
31	532 15 06-96	Bolt, Pivot
34	532 14 58-21	Bracket, Clutch Cable
35	532 14 64-80	Grommet, Handle
36	532 19 07-24	Bracket, Handle
37	532 10 26-04	Grip, Bar Control
39	810 04 05-00	Washer, Lock 5/16
38	873 80 05-00	Locknut 5/16-18
41	872 11 05-14	Bolt, Carriage 5/16-18 x 1-3/4
42	532 12 12-48	Bushing, Snap

NOTE: All component dimensions given in U.S. inches.
1 inch = 25.4 mm

REPAIR PARTS

TILLER - - MODEL NUMBER RYX820M

MAINFRAME, LEFT SIDE

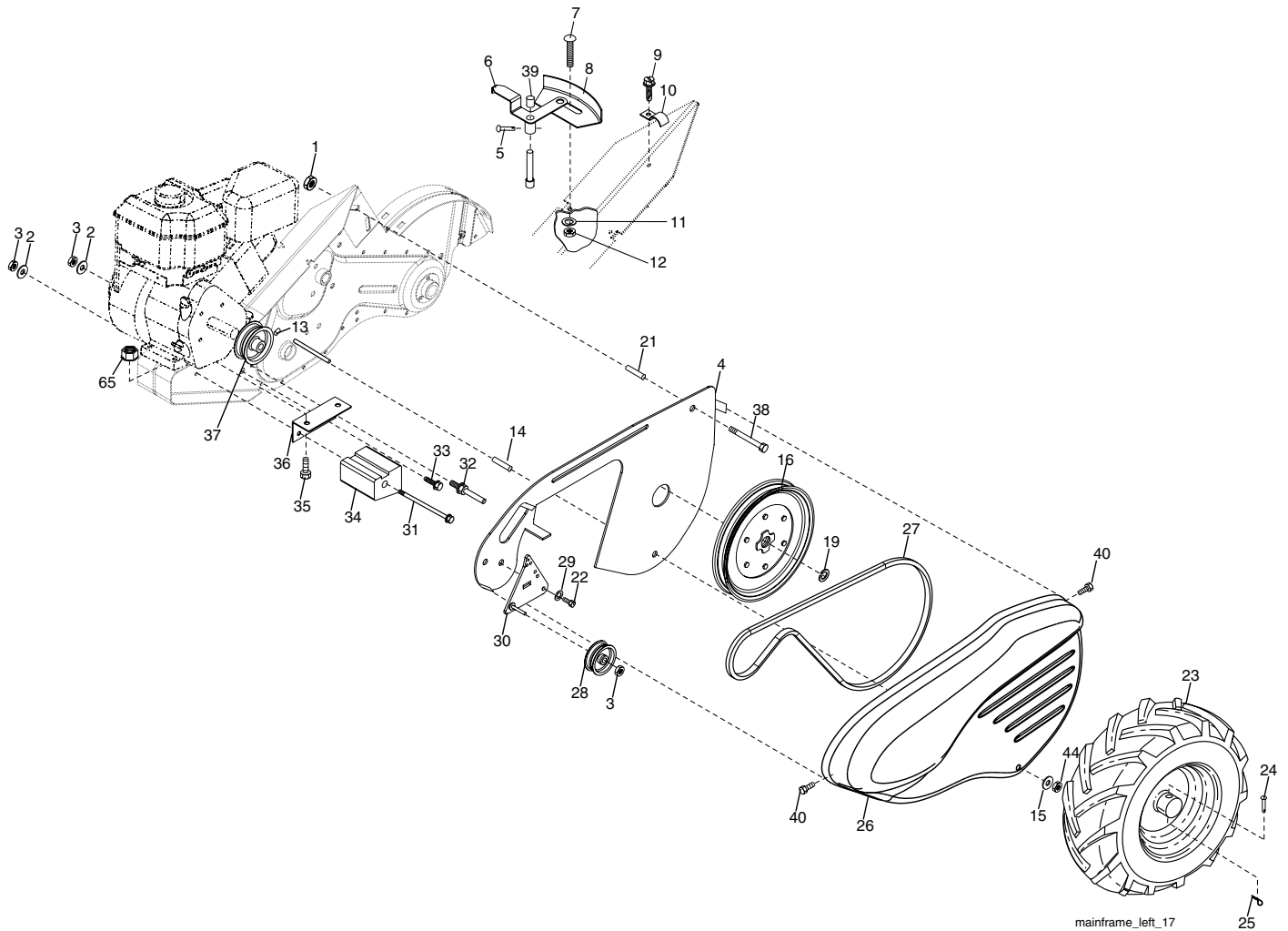

KEY NO.	PART NO.	DESCRIPTION
1	873 51 05-00	Nut, Keps 5/16-18
2	810 04 06-00	Washer, Lock 3/8
3	873 22 06-00	Nut, Hex 3/8-16
4	532 17 01-27	Shield, Inner, Belt Guard
5	532 16 43-29	Pin Spirol Flared
6	532 11 01-11	Lever, Shift
7	872 11 04-04	Bolt, Carriage 1/4-20 x 1/2 Gr. 5
8	532 00 87-00	Plate, Shift Indicator
9	532 08 67-77	Screw, Hex, Washer Head, Slotted #10-24 x 1/2
10	532 00 94-84	Clip
11	810 04 04-00	Washer, Lock 1/4
12	873 22 04-00	Nut, Hex 1/4-20
13	823 23 05-06	Screw, Set, Hex 5/16-18 x 3/8
14	532 15 61-17	Spacer, Split 0.327 x 0.42 x 1.220
15	819 11 11-16	Washer 11/32 x 11/16 x 16 Ga.
16	532 14 51-02	Sheave, Transmission
19	812 00 00-28	Ring, Retainer
21	532 11 06-52	Spacer, Split 0.327 x 0.42 x 2.09
22	874 77 05-08	Bolt Hex 5/16-24 x 1/2
23	532 10 21-90	Tire
	532 18 64-05	Rim
	532 12 47-18	Tire Valve

KEY NO.	PART NO.	DESCRIPTION
24	532 12 68-75	Rivet, Drilled
25	532 12 47-88	Clip, Hairpin
26	532 19 07-25	Guard, Belt
27	532 13 28-01	Belt, V
28	532 10 46-79	Pulley, Idler
29	812 00 00-32	Ring, Klip
30	532 15 92-29	Bracket, Idler
31	532 10 23-84	Bolt, Hex 5/16-16 x 12
32	532 10 21-41	Shaft, Idler Arm
33	874 76 06-16	Bolt, Hex 3/8-16 x 1
34	532 10 23-83	Counterweight, L. H.
35	874 76 05-24	Bolt, Hex 5/16-18 x 1-1/2
36	532 10 23-31	Bracket, Reinforcement, L. H.
37	532 13 08-12	Sheave, Engine
38	874 76 05-44	Bolt, Hex 5/16-18 x 2-3/4
39	532 14 00-62	Cap, Plunger
40	532 17 04-88	Screw, Hex Wsh Slit #10-24x .50
44	873 80 05-00	Nut, Lock 5/16-18
65	873 97 05-00	Nut, Lock Hex Flange

NOTE: All component dimensions given in U.S. inches.
1 inch = 25.4 mm

REPAIR PARTS

TILLER - - MODEL NUMBER RYX820M

MAINFRAME, RIGHT SIDE

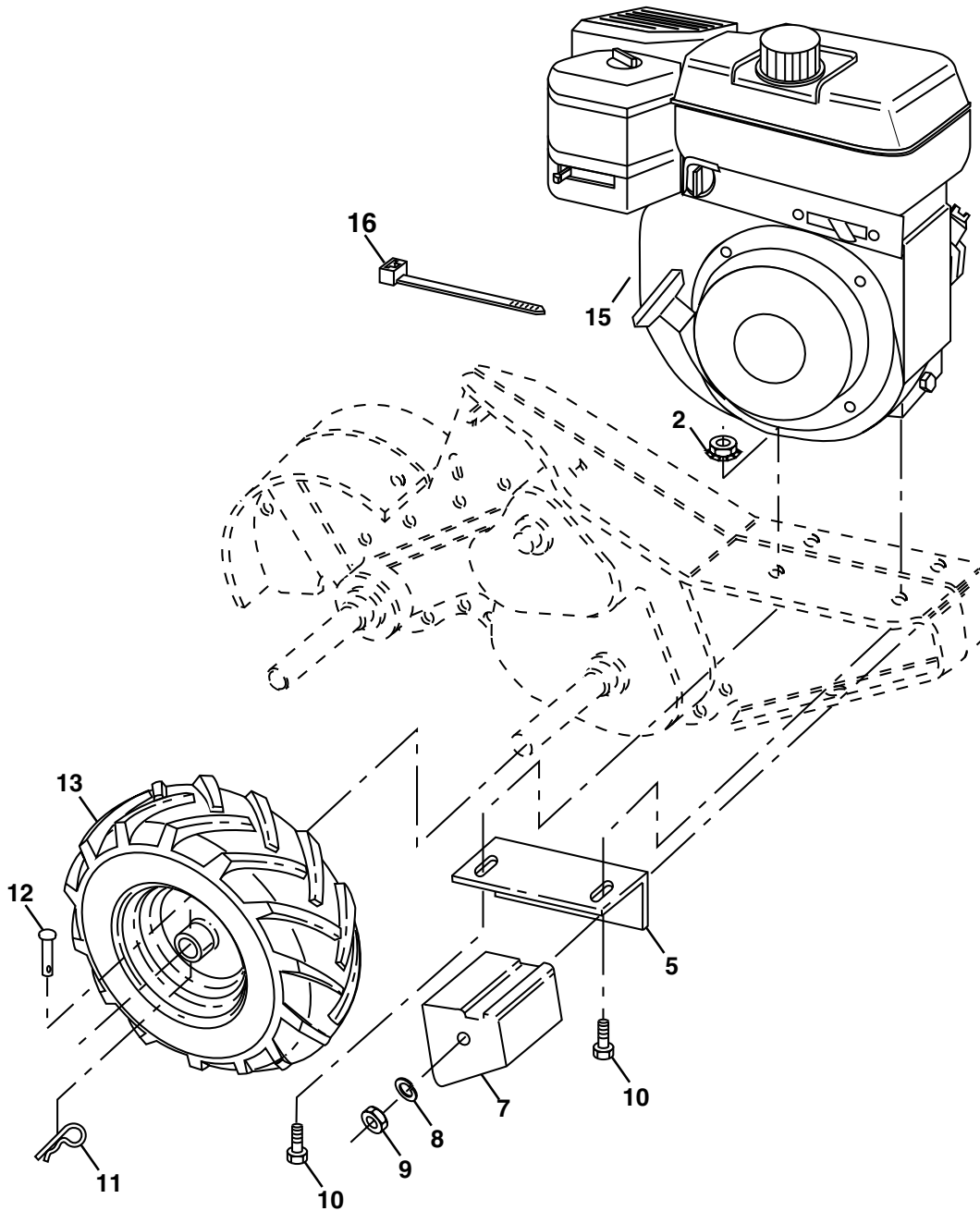

KEY NO.	PART NO.	DESCRIPTION
2	873 97 05-00	Nut, Hex Flange
5	532 10 23-32	Bracket, Reinforcement
7	532 10 21-73	Counter Weight, R.H.
8	810 04 06-00	Washer, Lock 3/8
9	873 22 06-00	Nut, Hex 3/8-16
10	874 76 05-24	Bolt, Hex 5/16-18 x 1-1/2
11	532 12 47-88	Clip, Hairpin
12	532 12 68-75	Rivet, Drilled

KEY NO.	PART NO.	DESCRIPTION
13	532 10 21-90	Tire
	532 18 64-05	Rim
	532 12 47-18	Tire Valve
15	-----	Engine, Briggs & Stratton Model No. 120302-0335-E1
16	532 12 47-56	Tie Cable

NOTE: All component dimensions given in U.S.inches.
1 inch = 25.4 mm

REPAIR PARTS

TILLER - - MODEL NUMBER RYX820M

TRANSMISSION

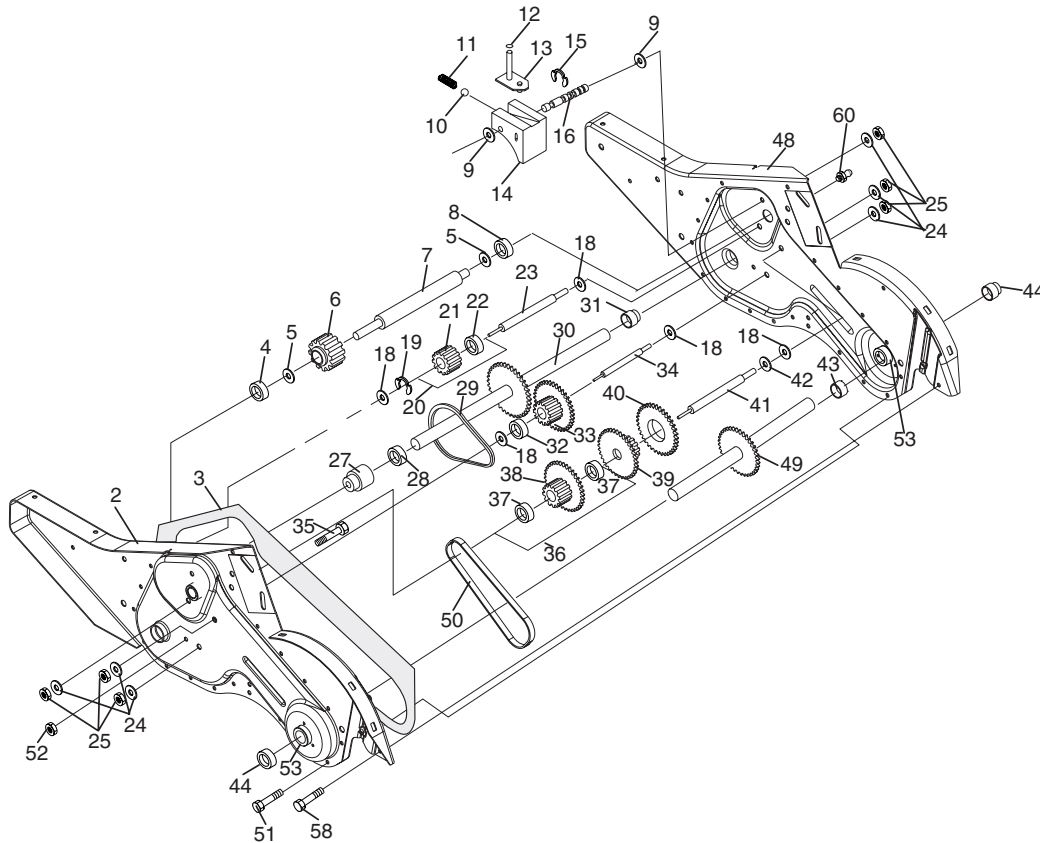

transmission_19.5b

KEY NO.	PART NO.	DESCRIPTION	KEY NO.	PART NO.	DESCRIPTION
1	532 18 85-54	Transmission Assembly (Includes Key Nos. 2-52)	30	532 15 07-37	Ground Shaft Assembly
2	532 18 84-82	Gearcase, L.H. w/Bearing (Includes Key No. 4)	31	532 14 30-08	Bearing, Shaft, Ground Drive
3	532 16 19-63	Gasket, Gearcase	32	532 10 63-88	Spacer 0.70 x 1.00 x 1.150
4	532 00 50-20	Bearing, Needle	33	532 10 21-21	Sprocket and Gear Assembly
5	532 00 13-70	Washer, Thrust 5/8 x 1.10 x 1/32	34	532 10 21-12	Shaft, Reduction (2nd)
6	532 13 73-35	Pinion, Input	35	532 10 21-01	Screw, Whiz, Lock 5/16-18 x 3-1/2
7	532 14 51-01	Shaft, Input	36	532 15 43-55	Sprocket Assembly w/Bearing (Includes Key Nos. 37 and 38)
8	532 00 48-95	Bearing, Needle	37	532 00 44-22	Bearing, Needle
9	532 15 44-67	Washer, Seal	38	532 15 43-56	Sprocket, Tine
10	532 00 73-92	Ball, Steel	39	532 10 53-45	Gear, Cluster, Red 1st & 2nd
11	532 10 03-71	Spring, Shift, Fork	40	532 10 53-46	Gear, Reverse
12	532 10 61-60	O-Ring	41	532 00 83-58	Shaft, Reduction (1st)
13	532 14 21-45	Arm, Shift	42	532 00 42-20	Washer, Thrust
14	532 00 83-53	Fork, Shift	43	532 10 61-46	Spacer 1.01 x 1.75 x 0.760
15	812 00 00-39	Ring, Klip	44	532 15 52-36	Seal Asm, Oil
16	532 15 44-66	Shaft, Shift	48	532 18 84-85	Gearcase, R.H. w/Bearing (Includes Key No. 8)
18	532 00 43-58	Washer	49	532 13 26-88	Shaft, Tine
19	812 00 00-40	Ring, Klip	50	532 10 61-47	Chain, Roller #50-50 Pitch
20	532 10 21-14	Gear, Assembly, Reverse Idler (Includes Key Nos. 21 and 22)	51	817 72 04-08	Screw 1/4-20 x 1/2
21	532 10 21-15	Gear, Reverse Idler	52	873 22 05-00	Nut, Hex 5/16-18
22	532 00 68-03	Bearing, Needle	53	532 16 51-40	Kit, Bearing, Tine Shaft
23	532 10 21-11	Shaft, Reverse Idler	58	532 17 95-20	Bolt Shoulder 1/4-20 x 7/8
24	810 04 07-00	Washer, Lock 7/16	60	532 18 32-26	Fitting Grease
25	873 61 07-00	Nut, Hex 7/16-20	--	532 00 60-66	Grease, Plastilube #1
27	532 14 30-09	Bearing, Shaft, Ground Drive			
28	532 10 63-90	Spacer 0.765 x 1.125 x 1.23			
29	532 10 21-34	Chain #35-50 Pitch			

NOTE: All component dimensions given in U.S. inches.
1 inch = 25.4 mm

REPAIR PARTS

TILLER - - MODEL NUMBER RYX820M

TINE SHIELD

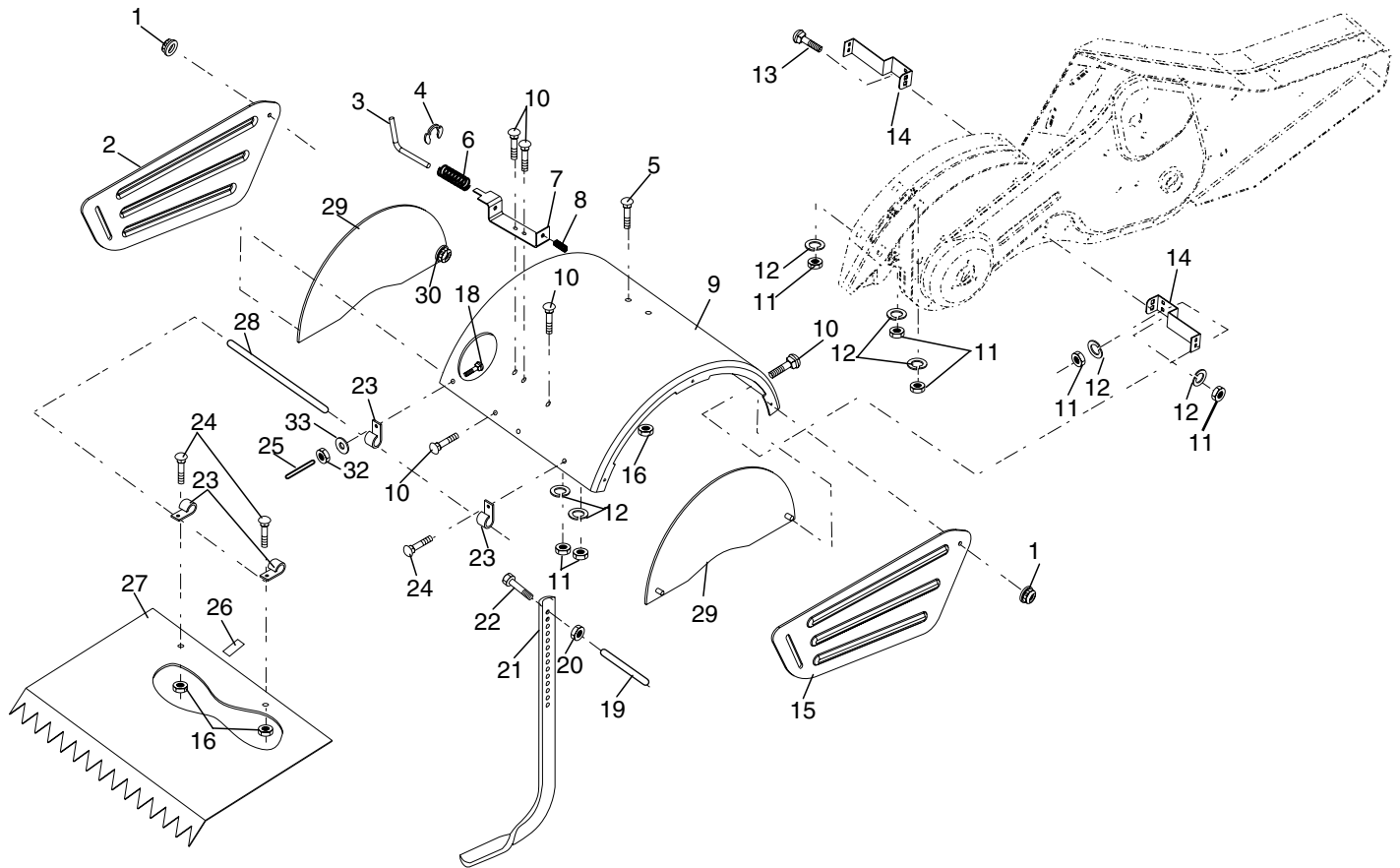

tine_shield_16_in

KEY NO.	PART NO.	DESCRIPTION
1	873 90 05-00	Nut, Flange 5/16-18
2	532 16 40-62	Shield, Side, Outer L. H.
3	532 00 83-93	Pin, Stake, Depth
4	812 00 00-35	Ring, Klip
5	532 18 08-47	Bolt, Carriage 5/16-18 x 3/4
6	532 00 83-94	Spring
7	532 00 83-92	Bracket, Latch
8	532 10 92-30	Spring, Depth Stake
9	532 12 54-09	Shield, Tine
10	872 14 05-08	Bolt 5/16-18 x 1
11	873 22 05-00	Nut, Hex 5/16-18
12	810 04 05-00	Washer, Lock 5/16
13	872 11 05-10	Bolt, Carriage 5/16-18 x 1-1/4
14	532 12 43-43	Bracket, Shield Tine
15	532 16 40-61	Shield, Side, Outer R.H.
16	873 90 04-00	Nut, Hex Flange 1/4-20 unc
18	872 04 04-10	Bolt, Carriage 1/4-20 x 1-1/4 Gr. 5

KEY NO.	PART NO.	DESCRIPTION
19	532 10 27-01	Grip
20	873 22 06-00	Nut, Hex 3/8-16
21	532 10 21-56	Stake, Depth
22	874 93 06-32	Bolt, Hex 3/8-16 x 2
23	532 00 44-40	Hinge
24	872 14 04-04	Bolt, Carriage 1/4-20 x 1/2 Gr. 5
25	532 00 67-12	Cap, Vinyl
26	532 10 92-27	Pad, Idler
27	532 12 54-10	Shield, Leveling
28	532 12 05-88	Pin, Hinge
29	532 12 54-26	Shield, Side
32	873 22 04-00	Nut Fin Hex 1/4-20 unc
33	810 04 04-00	Washer Lock Hvy Helical 1/4

NOTE: All component dimensions given in U.S. inches.
1 inch = 25.4 mm

REPAIR PARTS

TILLER - - MODEL NUMBER RYX820M

TINE ASSEMBLY

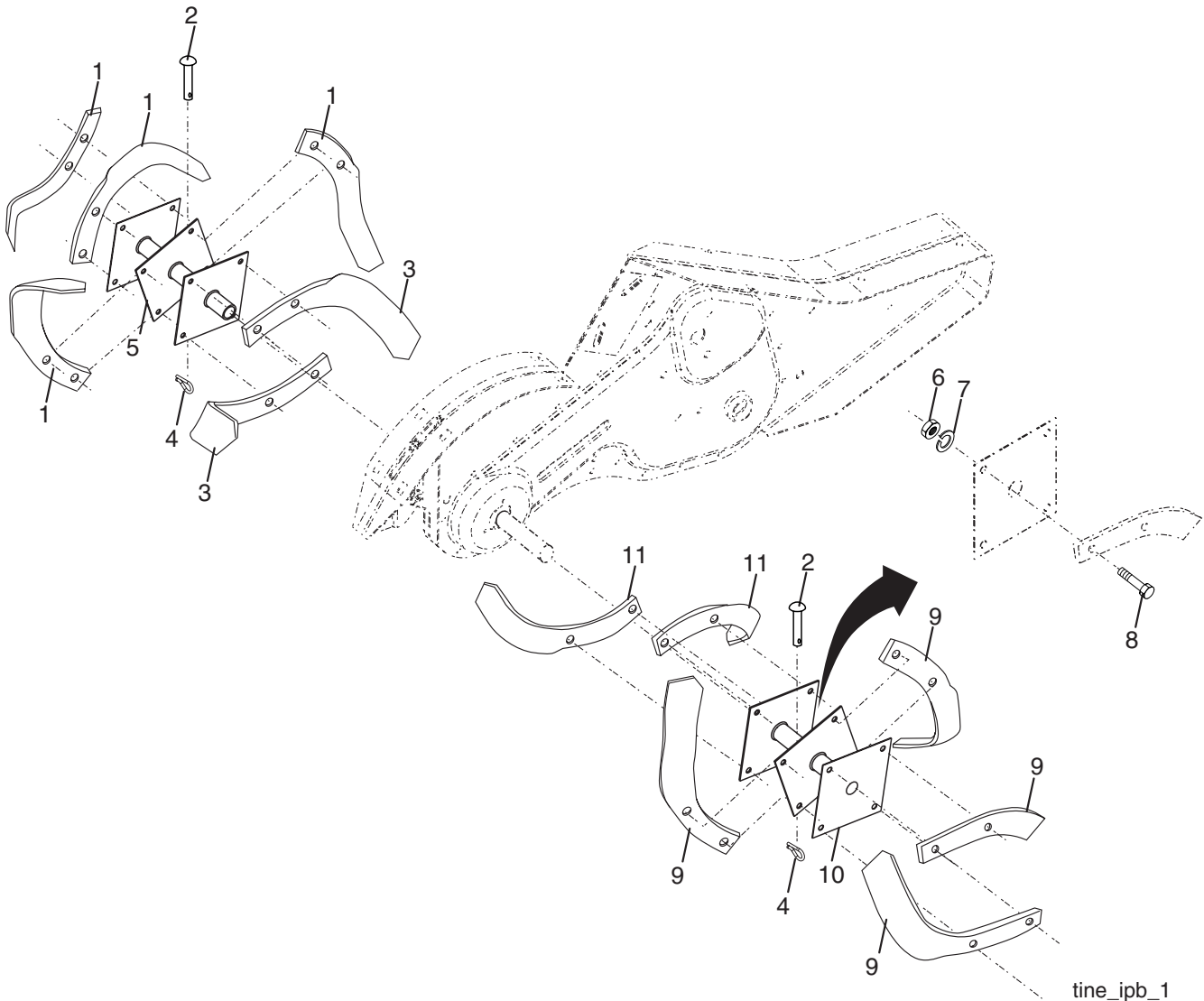

tine_ipb_1

KEY NO.	PART NO.	DESCRIPTION
1	532 00 44-59	Tine, Outer, L.H.
2	532 13 26-73	Clevis Pin
3	532 00 65-54	Tine, Inner, L.H.
4	532 12 46-60	Clip, Hairpin
5	532 13 27-27	Assembly, Hub and Plate, L.H.
6	873 61 06-00	Nut, Hex 3/8-24
7	810 04 06-00	Washer, Lock 3/8

KEY NO.	PART NO.	DESCRIPTION
8	874 61 06-16	Bolt, Hex 3/8-24 x 1
9	532 00 44-60	Tine, Outer, R.H.
10	532 13 27-28	Assembly, Hub and Plate, R.H.
11	532 00 65-55	Tine, Inner, R.H.

NOTE: All component dimensions given in U.S. inches.
1 inch = 25.4 mm

REPAIR PARTS

TILLER -- MODEL NUMBER RYX820M

DECALS

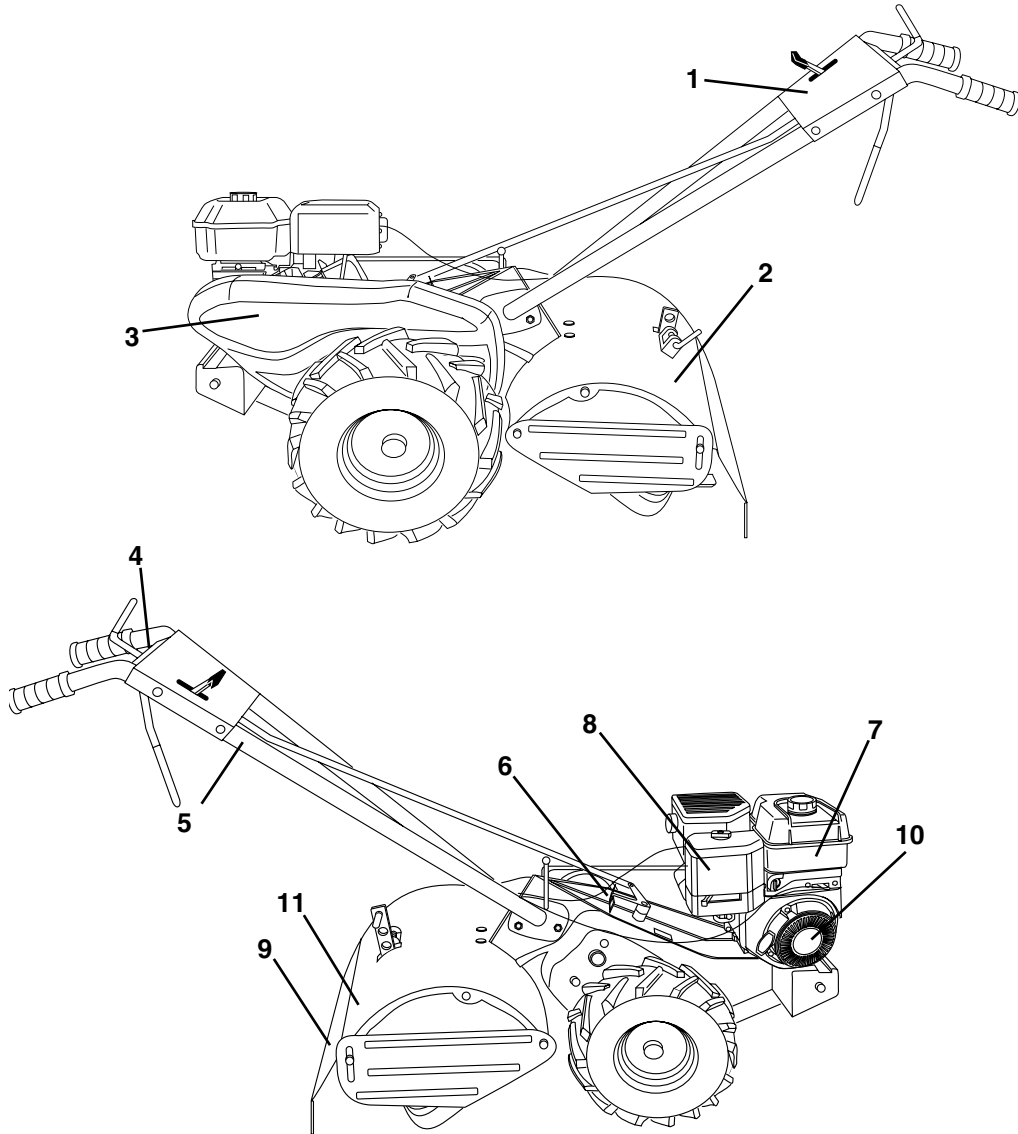

KEY NO.	PART NO.	DESCRIPTION
1	532 18 98-02	Decal, Logo
2	532 12 72-10	Decal, Description
3	532 16 73-79	Decal, Logo
4	532 11 06-78	Decal, Instruction, Tilling
5	532 15 98-77	Decal, Hand Placement
6	532 10 21-80	Decal, Shift Indicator
7	532 17 10-77	Decal, OHV N-I/C 190CELBL
8	532 17 56-43	Decal, Briggs & Stratton
9	532 17 65-57	Decal, Warning 4. Sym
10	532 17 10-78	Decal, Rewind INTEK
11	532 14 54-37	Decal, CE
--	532 18 13-19	Manual, Operator's (Euro)
--	532 18 13-20	Manual, Operator's (Scand)
--	532 18 98-33	Manual, Repair Parts

SERVICE NOTES

SERVICE NOTES

LIMITED WARRANTY

The Manufacturer warrants to the original consumer purchaser that this product as manufactured is free from defects in materials and workmanship. For a period of one (1) year from date of purchase by the original consumer purchaser, we will repair or replace, at our option, without charge for parts or labor incurred in replacing parts, any part which we find to be defective due to materials or workmanship. This Warranty is subject to the following limitations and exclusions.

1. This warranty does not apply to the engine or components parts thereof. Please refer to the applicable manufacturer's warranty on these items.
2. Transportation charges for the movement of any power equipment unit or attachment are the responsibility of the purchaser. Transportation charges for any parts submitted for replacement under this warranty must be paid by the purchaser unless such return is requested by your dealer.
3. The Warranty period for any products used for rental or commercial purposes is limited to 90 days from the date of original purchase.
4. This Warranty applies only to products which have been properly assembled, adjusted, operated, and maintained in accordance with the instructions furnished. This Warranty does not apply to any product which has been subjected to alteration, misuse, abuse, improper assembly or installation, delivery damage, or to normal wear of the product.
5. Exclusions: Excluded from this Warranty are belts, tines, tine adapters, normal wear, normal adjustments, standard hardware and normal maintenance.
6. In case of any problem within the boundaries of this warranty, contact the nearest department store, indicate the model number, serial number and the date of purchase of your machine. This warranty does not apply to accidental damages. All implicit warranties are limited to the same time frames. Or contact:

E.M. Services
54 Rue Lambrechts
92400 Courbevoie
France
Telephone: (1) 46678078
Fax: (1) 46678095

THIS WARRANTY DOES NOT APPLY TO INCIDENTAL OR CONSEQUENTIAL DAMAGES. ANY IMPLIED WARRANTIES ARE LIMITED TO THE SAME TIME PERIODS STATED HEREIN.

Rally