

REPAIR PARTS MANUAL
MODEL NO. RZ145H42C
Lawn Tractor

Rally

HOW TO USE THIS MANUAL

This manual is designed to provide the customer with a means to identify the parts on his/her tractor when ordering repair parts. The illustrations may or may not represent the actual assemblies; therefore, it is not recommended to use this manual as a guide to assemble or disassemble the tractor. Some hardware and parts are drawn larger in order to more readily identify them.

Each tractor has its own model number.

The model number for your tractor can be found on the fender under the seat.

When ordering parts, always give the following information:

- Product - "Lawn Tractor"
- Model Number - RZ145H42C
- Part Number
- Part Description

TABLE OF CONTENTS

SCHEMATIC	3
ELECTRICAL	4-5
CHASSIS AND ENCLOSURES	6-7
DRIVE	8-9
STEERING WHEEL	10-11
ENGINE	12-13
SEAT	14
DECALS	15
MOWER DECK	16-17
MOWER LIFT	18-19
WARRANTY	20

TRACTOR - MODEL NO. RZ145H42C PRODUCT NO. 954 56 76-97

SCHEMATIC

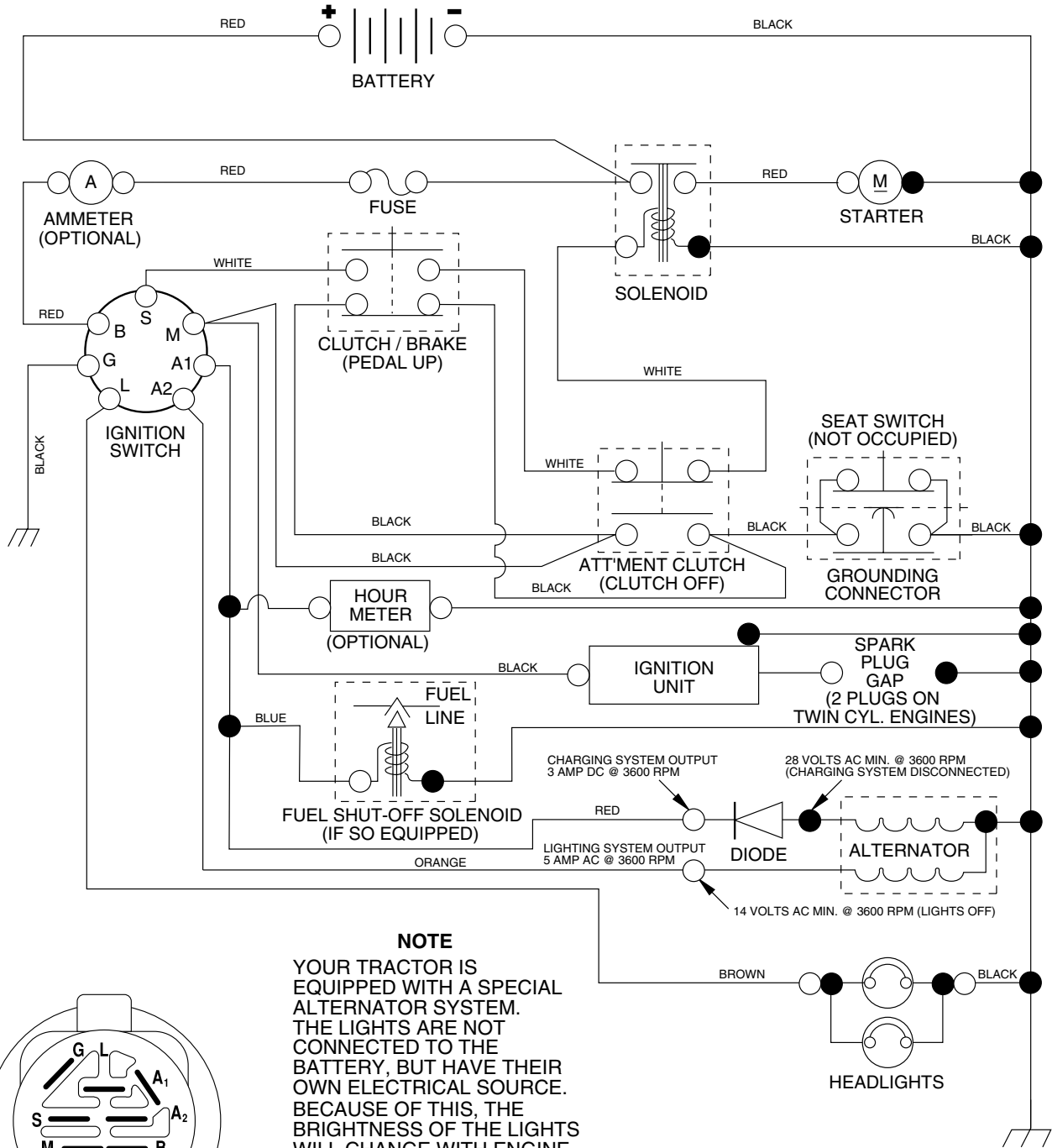

NOTE

YOUR TRACTOR IS EQUIPPED WITH A SPECIAL ALTERNATOR SYSTEM. THE LIGHTS ARE NOT CONNECTED TO THE BATTERY, BUT HAVE THEIR OWN ELECTRICAL SOURCE. BECAUSE OF THIS, THE BRIGHTNESS OF THE LIGHTS WILL CHANGE WITH ENGINE SPEED. AT IDLE THE LIGHTS WILL DIM. AS THE ENGINE IS SPEEDED UP, THE LIGHTS WILL BECOME THEIR BRIGHTEST.

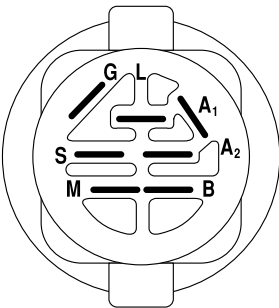

IGNITION SWITCH

POSITION	CIRCUIT	"MAKE"
OFF	M+G+A1	NONE
RUN/LIGHT	B+A1	A2+L
RUN	B+A1	NONE
START	B + S + A1	NONE

WIRING INSULATED CLIPS

NOTE: IF WIRING INSULATED CLIPS WERE REMOVED FOR SERVICING OF UNIT, THEY SHOULD BE REPLACED TO PROPERLY SECURE YOUR WIRING.

NON-REMOVABLE CONNECTIONS

REMOVABLE CONNECTIONS

REPAIR PARTS

TRACTOR - MODEL NO. RZ145H42C PRODUCT NO. 954 56 76-97
ELECTRICAL

KEY NO.	PART NO.	DESCRIPTION
1	532 16 34-65	Battery 12 Volt 28 AMP
2	874 76 04-12	Bolt Hex Hd 1/4-20unc X 3/4
8	532 17 66-89	Battery Box
16	532 17 61-38	Switch Interlock Push-In
21	532 17 56-85	Harness Asm Light W/4152j
22	532 00 41-52	Bulb Light #1156
24	532 12 47-80	Cable Battery 6 Ga 11" red
25	532 14 61-47	Cable Battery 6 Ga 44" red w/16 wire
26	532 17 51-58	Fuse 20 AMP
27	873 51 04-00	Nut Keps Hex 1/4-20 UNC
28	532 12 47-73	Cable Ground 6 Ga 12" black
29	532 12 13-05	Switch Plunger Nc Gray
30	532 17 55-66	Switch Ign
33	532 14 04-01	Key Ign Molded Generic
40	532 17 97-20	Harness Ign.
41	871 11 04-08	Bolt Blk Fin Hex 1/4 - 20 x 1/2
42	532 13 15-63	Cover Terminal Red
43	532 17 88-61	Solenoid
48	532 14 08-44	Adapter Ammeter Rectangular
52	532 14 19-40	Protection Wire Loop
90	532 18 04-49	Cover Terminal Battery

NOTE: All component dimensions given in U.S. inches.
1 inch = 25.4 mm.

REPAIR PARTS

TRACTOR - MODEL NO. RZ145H42C PRODUCT NO. 954 56 76-97
CHASSIS AND ENCLOSURES

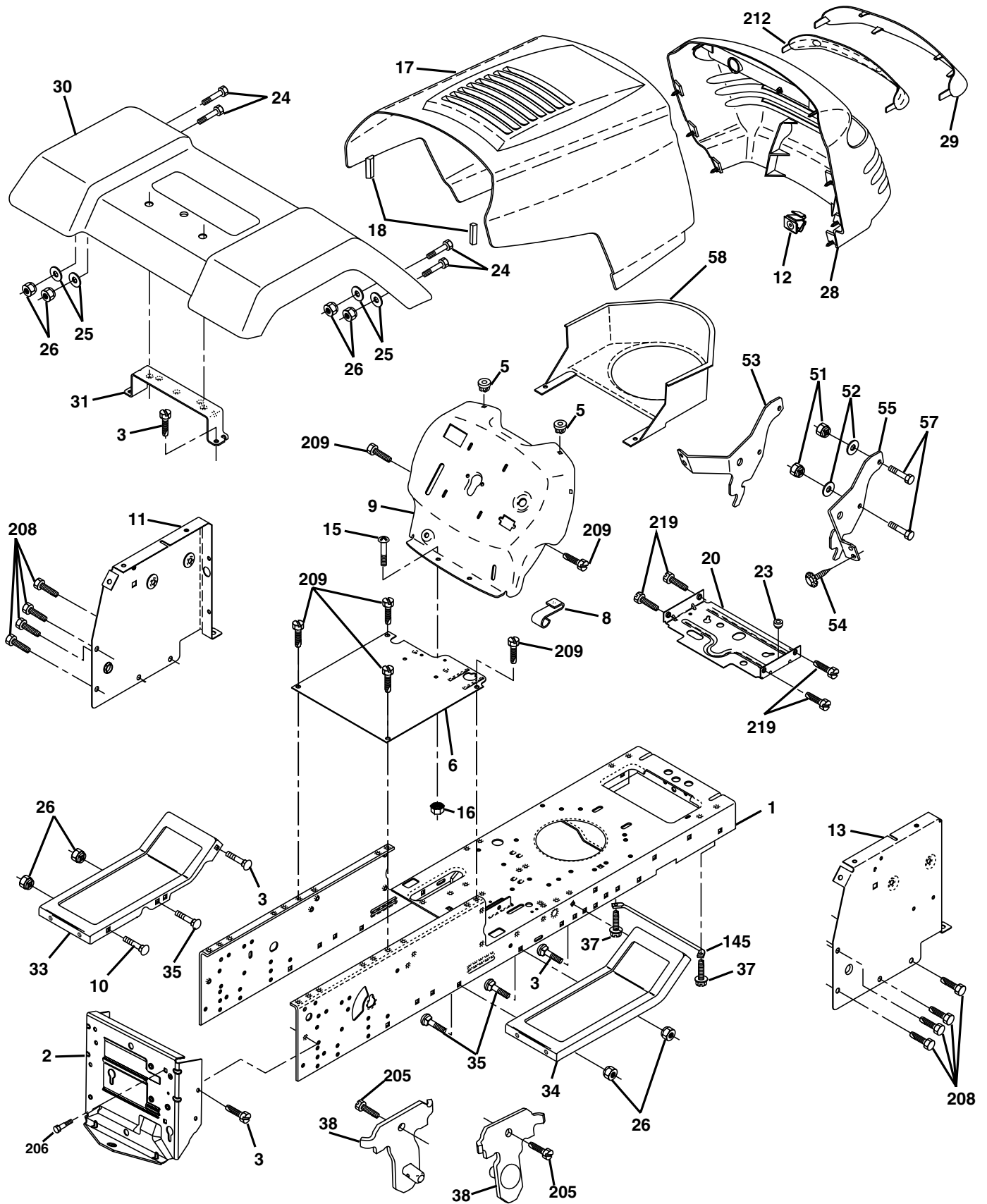

REPAIR PARTS

TRACTOR - MODEL NO. RZ145H42C PRODUCT NO. 954 56 76-97 CHASSIS AND ENCLOSURES

KEY NO.	PART NO.	DESCRIPTION
1	532 17 46-20	Chassis Stamping
2	532 17 65-54	Drawbar
3	817 06 06-12	Screw 3/8-16x3/4
5	532 15 52-72	Bumper Hood/Dash
6	532 15 59-23	Saddle
8	532 15 51-38	Clip Retainer
9	532 17 22-43	Dash P/L M
10	872 14 06-08	Bolt Carriage 3/8-16 x 1
11	532 17 49-96	Panel Dash Lh
12	532 14 56-60	Clip Tinnerman Grille
13	532 18 17-19	Panel Dash Rh
15	874 18 05-12	Screw Mach Thdr 5/16-18 Unc x 3/4
16	873 51 05-00	Nut Keps 5/16-18 Unc
17	532 16 35-57	Hood
18	532 12 69-38	Bumper Hood
20	532 18 06-79	Plate Mtg. Battery/Tank Fuel Fr.
23	532 12 40-28	Bushing Snap
24	874 78 06-16	Bolt Fin Hex 3/8-16 Unc x 1 Gr. 5
25	819 13 13-12	Washer 13/32 X 13/16 X 12 Ga
26	873 80 06-00	Nut Lock Hex W/Ins 3/8-16 Unc
28	532 17 91-01	Grille/Lens Asm.
29	532 16 81-54	Lens
30	532 17 45-11	Fender
31	532 13 66-19	Bracket Fender
33	532 18 11-93	Footrest LH
34	532 18 11-94	Footrest RH
35	872 11 06-06	Bolt Rdhd Sqnk 3/8-16 x 3/4
37	817 49 05-08	Screw Thdrol 5/16-18 x 1/2 TYT
38	532 17 57-10	Bracket Asm Pivot Mower Rear
51	873 80 04-00	Nut Lock w/Insert 1/4-20 Unc
52	819 09 14-16	Washer 9/32 x 7/8 x 16 Ga.
53	532 14 46-97	Bracket Grille LH
54	532 16 14-64	Screw Hex Wshd 8-18 x 7/8
55	532 14 46-96	Bracket Grille RH
57	874 78 04-12	Bolt Hex 1/4-20 x 3/4
58	532 15 01-27	Air Duct Engine P/L
145	532 15 65-24	Rod Pivot Chassis/Hood
205	817 49 06-08	Screw Thdrol 3/8-16 x 1/2
206	532 17 01-65	Bolt Shoulder 5/16-18 TT
208	817 67 06-08	Screw Thdrol 3/8-16 x 1/2 TYT BI
209	817 00 06-12	Screw Hexwsh Thdr 3/8-16 x 3/4
212	532 15 62-29	Insert Lens Reflect
219	817 00 05-12	Screw 5/16-18 x 3/4
--	532 00 54-79	Plug Button

NOTE: All component dimensions given in U.S. inches
1 inch = 25.4 mm

REPAIR PARTS

TRACTOR - MODEL NO. RZ145H42C PRODUCT NO. 954 56 76-97

DRIVE

KEY NO.	PART NO.	DESCRIPTION	KEY NO.	PART NO.	DESCRIPTION
1	-----	Transaxle Hydro Gr 322-0510 (Order parts from transaxle manufacturer)	69	532 14 24-32	Screw Hex Wsh 1/4-1/2 Unc
8	532 16 56-19	Rod Shift Fender	70	532 18 02-18	Guide Belt Mower Drive RH
10	876 02 04-16	Pin Cotter 1/8 x 1 CAD	71	532 16 91-83	Strap Torque Lh Hydro
14	810 04 04-00	Washer Lock Hvy Helical 1/4	73	532 16 91-82	Strap Torque Rh Hydro
15	874 49 05-44	Bolt Hex Flg Hd 5/16-18 X Gr.5	74	532 13 70-57	Spacer, Axle
16	873 80 05-00	Nut Lock Hex W/Ins. 5/16-18 Unc P	75	532 12 17-49	Washer 25/32 x 1-1/4 x 16 Gauge
19	873 80 06-00	Nut Lock Hex W/Wsh 3/8-16 Unc	76	812 00 00-01	E-Ring
21	532 10 69-33	Knob	77	532 12 35-83	Key, Square
22	532 16 94-98	Rod, Brake Hydro	78	532 12 17-48	Washer 25/32 x 1-5/8 x 16 Gauge
24	873 35 06-00	Nut	81	532 16 55-96	Shaft Asm. Cross Hydro
25	532 10 68-88	Spring, Brake Rod	82	532 12 37-82	Spring Torsion T/A
26	819 13 13-16	Washer	83	819 17 12-16	Washer 17/32 x 3/4 x 16 Ga.
27	876 02 04-12	Pin Cotter 1/8 x 3/4 CAD.	84	532 16 98-43	Link Transaxle
28	532 17 57-65	Rod, Parking Brake	89	532 17 30-29	Console, Shift
29	532 07 16-73	Cap, Parking Brake	95	532 17 02-01	Control Asm Bypass Hydro
30	532 17 49-73	Bracket, Transaxle	96	532 12 47-88	Retainer Spring 1" Zinc/Cad
32	874 76 05-12	Bolt Hex Hd 5/16-18 Unc x 3/4	103	873 94 08-00	Nut Hex Jam Toplock 1/2-20 Unf
34	532 17 55-78	Shaft, Foot Pedal	116	872 14 06-08	Bolt 3/8-16 Unc x 1
35	532 12 01-83	Bearing, Nylon	120	873 90 06-00	Nut Lock 3/8-16 Unc
36	819 21 16-16	Washer	150	532 17 54-56	Spacer Retainer
37	532 12 49-63	Pin, Roll	151	819 13 32-10	Washer 13/32 x 2 x 10 Ga.
38	532 17 91-14	Pulley, Idler, Composite	156	532 16 60-02	Washer Srrtd 5/16 ID x 1.0 x .125 Tk
39	874 76 06-48	Bolt Fin Hex 3/8-16 Unc x 2-3/4	158	532 16 55-89	Bracket Shift Mount
41	532 17 55-56	Keeper, Belt Idler	159	532 16 54-94	Hub Tapered Flange Shift LT
47	532 12 77-83	Pulley, Idler, V-Groove	161	872 14 04-06	Bolt Rdhd Sqnk 1/4-20 x 3/4 Gr. 5
48	532 15 44-07	Bellcrank Clutch Grnd Drv Stl	162	873 68 04-00	Nut Crownlock 1/4-20 Unc
49	532 12 32-05	Retainer, Belt	163	874 78 04-16	Bolt Hex Fin 1/4-20 unc x 1 Gr. 5
50	874 76 06-24	Bolt Hex 3/8-16 Unc x 1-1/2	164	819 09 10-10	Washer 5/8 x .281 x 10 Ga
51	873 68 06-00	Nut Crownlock 3/8-16	165	532 16 56-23	Bracket Pivot Lever
52	873 68 05-00	Nut Crownlock 5/16-18	166	532 16 68-80	Screw 5/16-18 x 5/8 TT Yellow
53	532 10 57-10	Link, Clutch	168	532 16 54-92	Bolt Shoulder 5/16-18 x .561 TT
55	532 10 57-09	Spring, Return, Clutch	169	532 16 55-81	Plate Fastening
56	874 76 06-20	Bolt Fin Hex 3/8-16 UNC x 1-1/4	171	817 49 06-08	Screw Thdrl 3/8-16 x 1/2
57	532 14 02-94	V-Belt, Ground Drive	197	532 16 96-13	Nyliner Snap-In 5/8" ID
59	532 16 96-91	Keeper, Center Span	198	532 16 95-93	Washer Nyl 7/8 ID x .105 HYD CRD
61	817 12 06-14	Screw 3/8-16 x .875	199	532 16 96-12	Bolt Shoulder 5/16-18 Unc
62	532 12 48-72	Cover, Pedal	200	872 14 05-08	Bolt Rdhd Sqnk 5/16-18 Unc x 1
63	532 18 02-19	Pulley, Eng	202	872 11 06-14	Bolt Carr Sh 3/8-16 x 1-3/4 Gr. 5
64	871 17 07-64	Bolt Hex 7/16-20 x 4 Ga. 5	205	819 17 16-16	Washer 17/32 x 1 x 16 Ga.
65	810 04 07-00	Washer	212	532 14 52-12	Nut Hexflange Lock
66	532 15 47-78	Keeper Belt Engine	250	817 06 06-12	Screw 3/8-16 x .75

NOTE: All component dimensions given in U.S. inches
1 inch = 25.4 mm

REPAIR PARTS

TRACTOR - MODEL NO. RZ145H42C PRODUCT NO. 954 56 76-97
STEERING ASSEMBLY

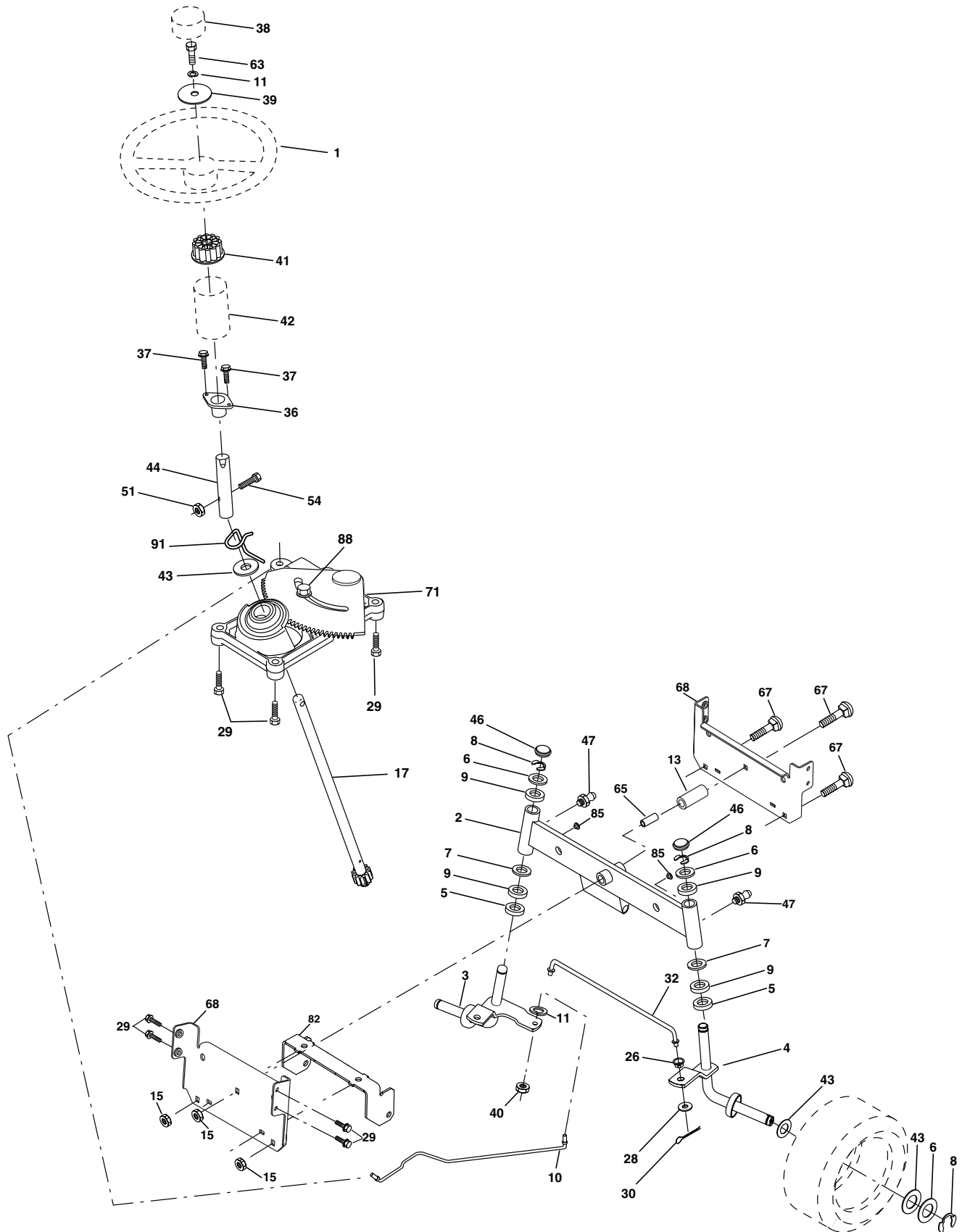

REPAIR PARTS

TRACTOR - MODEL NO. RZ145H42C PRODUCT NO. 954 56 76-97 STEERING ASSEMBLY

KEY NO.	PART NO.	DESCRIPTION
1	532 17 59-04	Wheel Steering
2	532 17 51-31	Axle Asm
3	532 16 98-40	Spindle Asm LH
4	532 16 98-39	Spindle Asm RH
5	532 12 49-31	Bearing Race Thrust Harden
6	532 12 17-48	Washer 25/32 X 1-5/8 X 16 Ga
7	819 27 20-16	Washer 27/32 X 1-1/4 X 16 Ga
8	812 00 00-29	Ring Klip #t5304-75
9	532 12 49-37	Bearing Col Strg Blk
10	532 17 51-21	Link Drag
11	810 04 06-00	Washer Lock Hvy Hlcl Spr 3/8
13	532 13 65-18	Spacer Brg Axle Front
15	532 14 52-12	Nut Hex Flange Lock
17	532 17 78-76	Shaft Asm Strg
26	532 12 68-47	Bushing Link Drag Blk LR
28	819 13 14-16	Washer 13/32 X 7/8 X 16 Ga
29	817 06 06-12	Screw 3/8-16x3/4
30	876 02 04-12	Pin Cotter 1/8 X 3/4 Cad
32	532 13 04-65	Rod Tie Wire Form 19 75 Mech
36	532 15 50-99	Bushing Strg
37	532 15 29-27	Screw
38	532 17 59-05	Cap Strg Wh
39	819 13 38-12	Washer 13/32 X 2-3/8 x 12
40	532 12 47-01	Lock nut
41	532 10 07-11	Adaptor Wheel Strg
42	532 16 96-33	Boot Steering Shaft
43	532 12 17-49	Washer 25/32 X 1-1/4 X 16 Ga
44	532 15 37-20	Extension Steering Shaft LR/LT
46	532 12 12-32	Cap Spindle Fr Top Blk
47	532 12 48-36	Fitting Grease
51	873 80 05-00	Nut Lock Hex w/Ins 5/16-18
54	874 78 05-20	Bolt Fin Hex 5/16-18 Unc x 1-1/4
63	874 78 06-16	Bolt Fin Hex 3/8-16unc x 1 Gr. 5
65	532 16 03-67	Spacer Brace Axle
67	872 14 06-18	Bolt, Rdhd Sqnk 3/8-16 x 2-1/4
68	532 16 98-27	Axle, Brace
71	532 17 51-46	Steering Asm.
82	532 16 98-35	Bracket Susp Chassis Front
85	532 13 38-35	Fastener Christmas Tree
88	532 17 51-18	Bolt Shoulder 7/16-20
91	532 17 55-53	Clip Steering

NOTE: All component dimensions given in U.S. inches.
1 inch = 25.4 mm.

REPAIR PARTS

TRACTOR - MODEL NO. RZ145H42C PRODUCT NO. 954 56 76-97

ENGINE

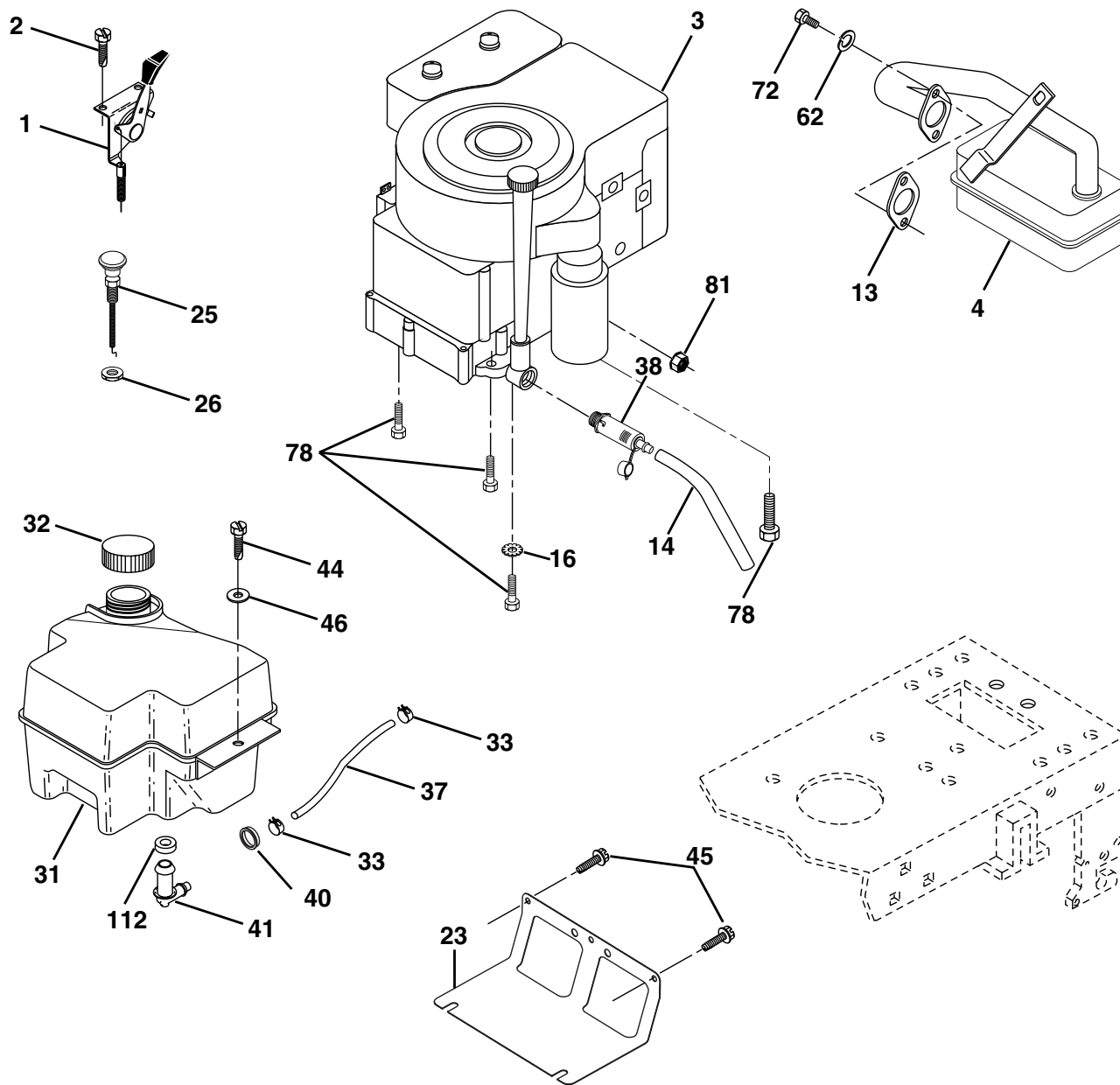

OPTIONAL EQUIPMENT
Spark Arrester

REPAIR PARTS

TRACTOR - MODEL NO. RZ145H42C PRODUCT NO. 954 56 76-97

ENGINE

KEY NO.	PART NO.	DESCRIPTION
1	532 17 05-51	Control Th/ch Flag
2	817 72 04-08	Screw Hex Thd Cut 1/4-20 x 1/2
3	-----	Engine B&S Model No. 287707 (Order Parts From Engine Manufacturer)
4	532 13 73-52	Muffler
13	532 16 52-91	Gasket Eng 1 313 Id Tin Plated
14	532 14 84-56	Tube Drain Oil Easy
16	811 05 06-00	Washer Lock Ext Tooth 3/8
23	532 16 98-37	Shield Brn/Dbr Guard
25	532 18 09-45	Control Choke
26	873 92 06-00	Nut Keps 3/8-24 Unf
29	532 13 71-80	Kit Spark Arrestor (Flat Scrn)
31	532 18 06-45	Tank Fuel Front
32	532 14 05-27	Cap Asm Fuel W/sym Vented
33	532 12 34-87	Clamp Hose Black
37	532 13 70-40	Line Fuel 20"
38	532 14 83-15	Plug Drain Oil Easy
40	532 12 40-28	Bushing Snap Nyl Blk Fuel Line
41	532 12 49-52	Bushing
44	817 67 04-12	Screw Hexwsh Thdrol 1/4-20x3/4
45	817 00 06-12	Screw Hex Wsh Thdrol 3/8-16 x 3/4
46	819 09 14-16	Washer 9/32 X 7/8 X 16 Ga
62	810 04 05-00	Washer Lock Hvy Hlcl Spr 5/16
72	871 07 05-12	Screw Hexhd Cap 5/16-18 x 3/4
78	817 06 06-20	Screw 3/8-16x1-1/4
81	873 51 04-00	Nut 1/4-20
112	532 13 92-77	Stem Tank Fuel

NOTE: All component dimensions given in U.S. inches
1 inch = 25.4 mm

REPAIR PARTS

TRACTOR - MODEL NO. RZ145H42C PRODUCT NO. 954 56 76-97

SEAT ASSEMBLY

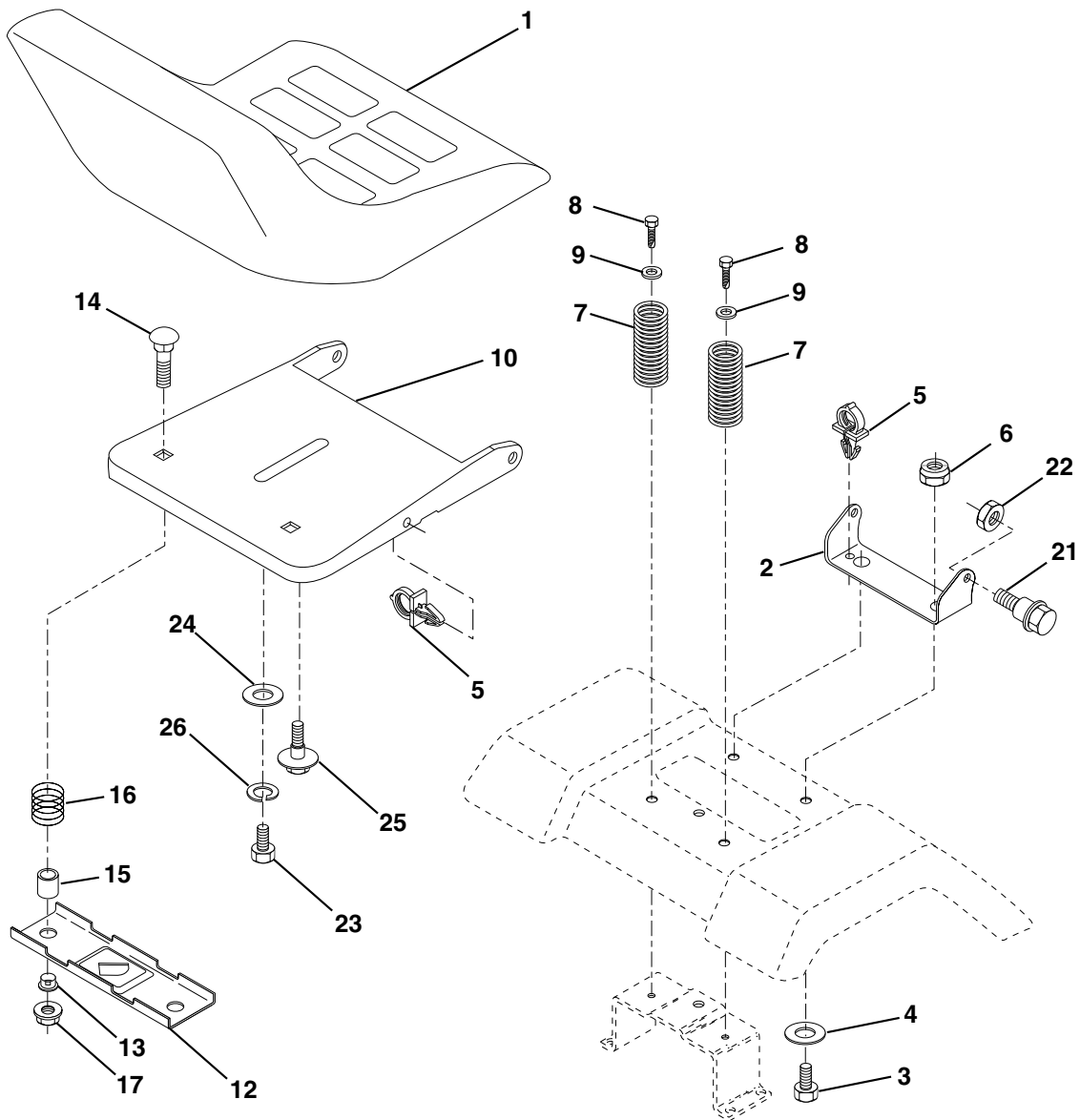

KEY NO.	PART NO.	DESCRIPTION
1	532 12 74-28	Seat
2	532 14 05-51	Bracket Pivot Seat 8 720
3	871 11 06-16	Bolt Fin Hex 3/8-16unc X 1
4	819 13 16-10	Washer 13/32 X 1 X 10 Ga
5	532 14 50-06	Clip Push-In
6	873 80 06-00	Nut Hex w/Ins. 3/8-16 Unc
7	532 12 41-81	Spring Seat Cprsn 2 250 Blk Zi
8	817 00 06-16	Screw 3/8-16 X 1-1/2
9	819 13 16-14	Washer 13/32 X 1 X 14 Ga.
10	532 18 24-93	Pan Seat
12	532 12 12-46	Bracket Mounting Switch
13	532 12 12-48	Bushing Snap Blk Nyl 50 Id

KEY NO.	PART NO.	DESCRIPTION
14	872 05 04-12	Bolt Rdhd Sqnk 1/4-20x1-1/2
15	532 13 43-00	Spacer Split 28x 96 Yel Zinc
16	532 12 12-50	Spring Cprsn 1 27 Blk Pnt
17	532 12 39-76	Nut Lock 1/4 Lge Flg Gr 5 Zinc
21	532 17 18-52	Bolt Shoulder 5/16-18 Unc
22	873 80 05-00	Nut Hex Lock W/Ins 5/16-18
23	871 11 08-14	Bolt Hex
24	819 17 19-12	Washer 17/32 X 1-3/16 X 12 Ga.
25	532 12 70-18	Bolt Shoulder 5/16-18 X 62
26	810 04 08-00	Washer Lock Hvy HLCL SPR 1/2

NOTE: All component dimensions given in U.S. inches.
1 inch = 25.4 mm

REPAIR PARTS

TRACTOR - MODEL NO. RZ145H42C PRODUCT NO. 954 56 76-97

DECALS

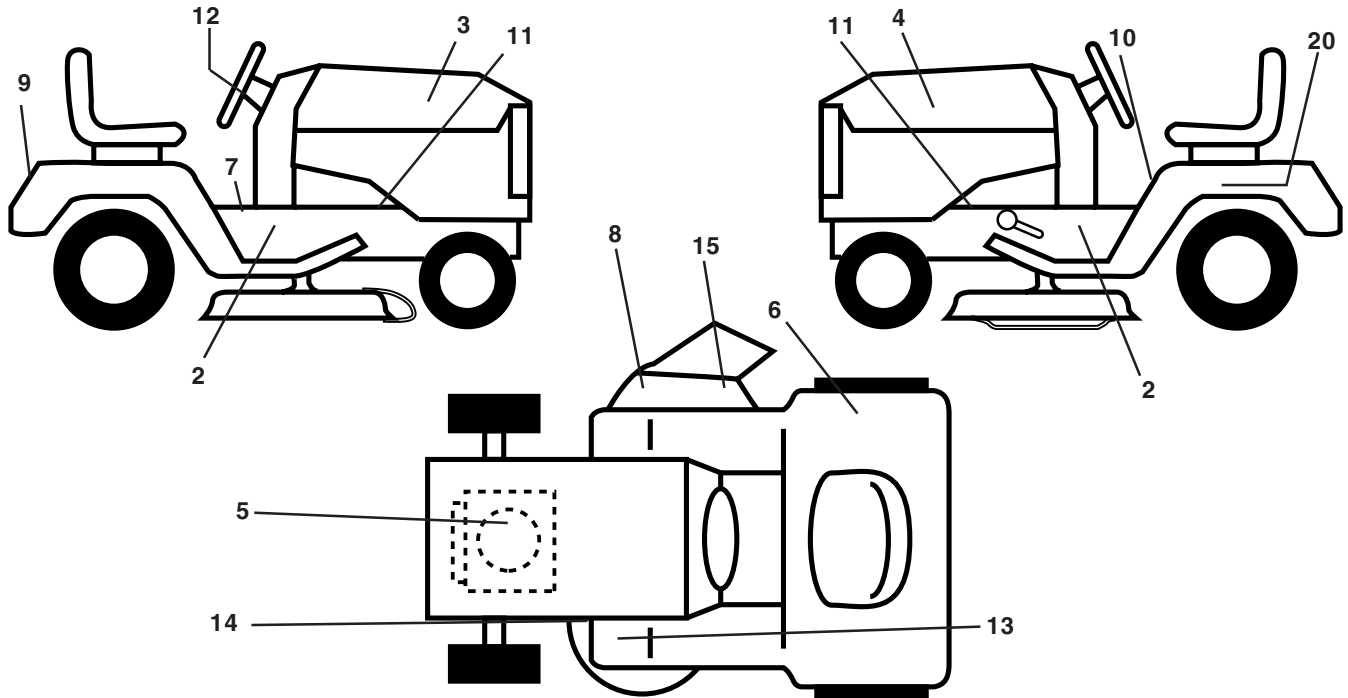

KEY NO.	PART NO.	DESCRIPTION	KEY NO.	PART NO.	DESCRIPTION
2	532 18 11-49	Decal Chassis HP	13	532 15 97-37	Decal Brake/Clutch Symbol LT
3	532 18 11-44	Decal Hood RH	14	532 16 03-96	Decal V-Belt Schematic
4	532 18 11-45	Decal Hood LH	15	532 18 21-66	Decal Mower Cutting Finger Symbol
5	532 17 63-98	Decal HP Engine	20	532 14 50-05	Decal Bat Dan/Psn
6	532 18 04-32	Decal Fender 100 DB/CE	--	532 16 25-98	Decal Drawbar Load Limit
7	532 14 08-37	Decal Saddle Brake	--	532 16 92-10	Decal By-Pass Lt Hydro
8	532 17 91-28	Decal Deck "B" 42"	--	532 13 83-11	Decal Handle Lft Height Adjust
9	532 18 11-46	Decal Fender	--	532 18 28-92	Manual Operator's (Euro)
10	532 14 54-98	Decal Read Owner's Manual Syms.	--	532 18 28-93	Manual Operator's (Scand)
11	532 15 97-36	Decal Chassis Hot Muffler	--	532 18 29-00	Manual Parts
12	532 14 69-02	Decal Wheel Steering			

WHEELS & TIRES

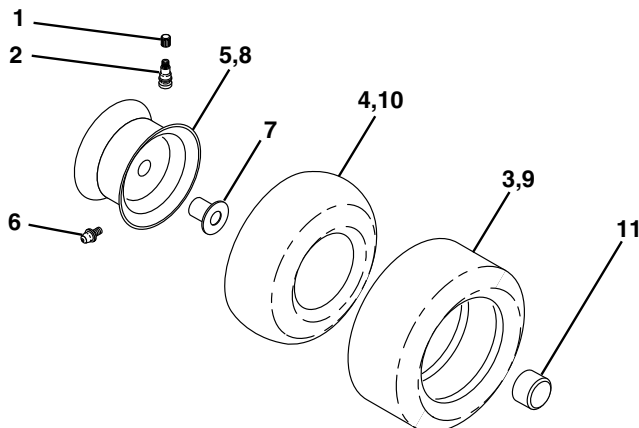

KEY NO.	PART NO.	DESCRIPTION
1	532 05 91-92	Cap Valve Tire
2	532 06 51-39	Stem Valve
3	532 10 62-22	Tire F Ts 15 X 6 0 - 6 Service
4	532 05 99-04	Tube Front (Service Item Only)
5	532 14 14-46	Rim Asm 6" front Service
6	532 12 49-57	Fitting Grease (Front Wheel Only)
7	532 12 49-59	Bearing Flange (Front Wheel Only)
8	532 14 14-47	Rim Asm 8" rear Service
9	532 10 62-68	Tire R Ts 18 x 9.5-8 C Service
10	532 12 49-26	Tube Rear (Service Item Only)
11	532 17 50-39	Cap Axle Blk 1 50 X 1 00
--	532 14 43-34	Sealant, Tire (10 oz. Tube)

NOTE: All component dimensions given in U.S. inches
1 inch = 25.4 mm

REPAIR PARTS

TRACTOR - MODEL NO. RZ145H42C PRODUCT NO. 954 56 76-97

MOWER DECK

KEY NO.	PART NO.	DESCRIPTION	KEY NO.	PART NO.	DESCRIPTION
1	532 16 58-92	Deck Asm MWR 42"weldment	50	532 13 13-40	Bolt Shldr 10-24 Zinc Gr 5 42"
2	872 14 05-06	Bolt Rdhd Sqnk 5/16-18unc X3/4	51	532 06 91-80	Nut Lock #10-24 Unc
3	532 13 80-17	Bracket Asm Fr Sway Bar 38/42	52	532 13 98-88	Bolt Shoulder 5/16-18 Unc Blkz
4	532 16 54-60	Bracket Asm Deck 42"sway Bar	53	532 13 18-45	Arm Asm Pad Brake
5	532 12 46-70	Retainer Spring	54	532 13 39-43	Washer Hardened
6	532 17 80-24	Bar Sway Deck	55	532 15 50-46	Arm Idler 42"mower LT/YT
8	532 85 08-57	Bolt 3/8 - 24 X 1.25 Gr 8	56	532 16 57-23	Spacer Retainer Mower
9	810 03 06-00	Washer Lock Hvy 3/8	59	532 14 10-43	Guard TUV Idler
10	532 14 02-96	Washer Hard Blade Mower Vented	67	532 10 69-32	Knob Rd 3/8-16 Plstc Thds Blk
11	532 13 84-98	Blade Mower 42"	68	532 18 02-15	V-Belt Mower 42"
13	532 13 76-45	Shaft Asm W/lower Bearing	142	532 16 58-90	Arm Spring Brake Mower
14	532 12 87-74	Housing Mandrel Vented	143	532 15 71-09	Bracket Arm Idler 42"
15	532 11 04-85	Bearing Ball Mandrel	144	532 15 86-34	Keeper Belt 42" Clutch Idler
16	532 17 44-93	Stripper Mower Vented	145	532 16 58-88	Pulley Idler Flat
18	872 14 05-05	Bolt Rdhd Sqnk 5/16-18 X 5/8	146	532 17 19-77	Bolt Carriage Idler
19	532 13 28-27	Bolt Shoulder	147	532 17 97-48	Spring Extension
20	532 15 97-70	Baffle Vortex 42	148	532 16 90-22	Spring Return Idler
21	873 68 05-00	Nut Crownlock 5/16-18 UNC	149	532 16 98-98	Retainer Spring Yellow
23	532 17 75-63	Bracket Deflector Mower 42"	150	819 09 12-16	Washer 9/32 x 3/4 x 16 Ga.
24	532 10 53-04	Cap Sleeve 80x 112 Blk Mower	151	532 16 96-70	Bracket Clutch Cable
25	532 12 37-13	Spring Torsion Deflector 2 52	152	532 18 15-55	Clutch Cable 42"
26	532 11 04-52	Nut Push Phos & Oil	153	532 16 96-74	Washer Flat 3/8" Type B
27	532 17 18-59	Shield Deflector Mower 42" Blk	154	532 16 96-75	Spring Retainer
28	819 11 10-16	Washer 11/32 X 5/8 X 16 Ga	155	532 16 96-71	Spring Retention Lvr Cltch Cab
29	532 13 14-91	Rod Hinge 42"6 75 Wlg	156	532 16 96-72	Spacer Clutch Cable
30	532 17 39-84	Screw Thd Rolling Washer Head	157	532 16 96-69	Rod Clutch Cable 3/8"
31	532 12 99-63	Washer Spacer Mower Vented	158	817 72 04-08	Screw Hex Thd Cut 1/4-20 x 1/2
32	532 15 35-35	Pulley Mandrel 42"	159	872 14 06-14	Bolt Rdhd Sqnk 3/8-16 Unc x 1-3/4
33	532 17 83-42	Nut 9/16 Toplock Flng Oil Dip	--	532 13 07-94	Mandrel Asm Service (Includes Housing, Shaft and Shaft Hardware Only-Pulley Not Included)
34	872 11 06-14	Bolt Rdhd 3/8-16uncx1-3/4 Gr5	--	532 18 19-25	Replacement Mower, Complete
36	532 13 14-94	Pulley Idler Flat 3 060			
37	819 13 13-16	Washer 13/32 X 13/16 X 16			
40	873 68 06-00	Nut Crownlock 3/8-16 UNC			
44	532 14 00-88	Guard Mandrel LH Black			
45	532 12 47-88	Spring Retainer 1" Zinc/cad			
46	532 13 77-29	Screw Hex Thd Cut 1/4-20x5/8 T			
48	532 13 39-44	Washer Hardened Smaller			
49	532 17 42-84	Roller Asm Cam Follower			

NOTE: All component dimensions given in U.S. inches
1 inch = 25.4 mm

REPAIR PARTS

TRACTOR - MODEL NO. RZ145H42C PRODUCT NO. 954 56 76-97

MOWER LIFT

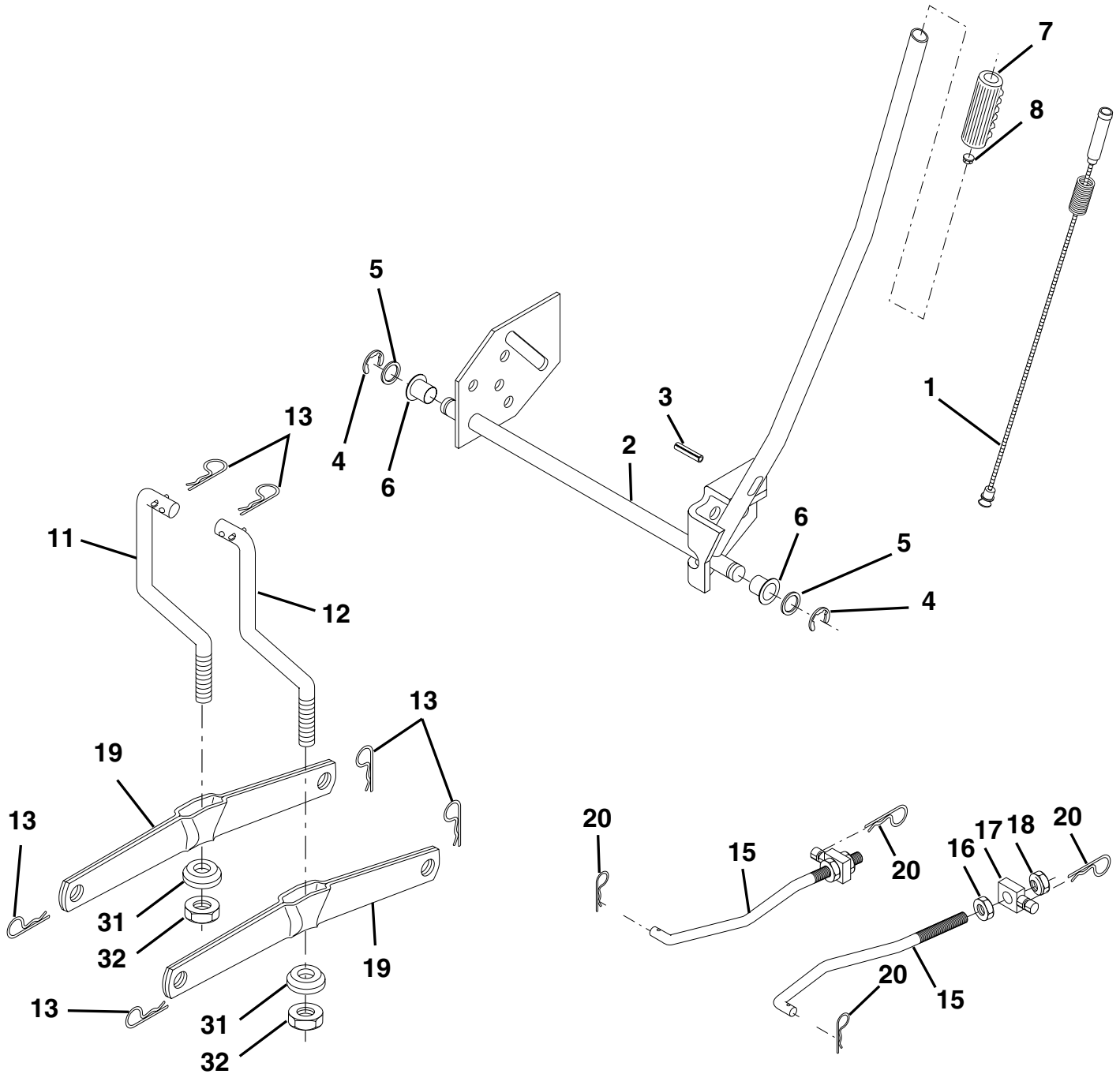

REPAIR PARTS

TRACTOR - MODEL NO. RZ145H42C PRODUCT NO. 954 56 76-97
MOWER LIFT

KEY NO.	PART NO.	DESCRIPTION
1	532 15 94-60	Wire Asm Inner W/plunger 17 32
2	532 15 94-71	Shaft Asm Lift LH Inf Hgt P/L
3	532 10 57-67	Pin Groove 1 500 Zinc
4	812 00 00-02	E Ring #5133-62
5	819 21 16-21	Washer 21/32 X 1 X 21 Ga
6	532 12 01-83	Bearing Nylon Blk 629 Id
7	532 10 94-13	Grip Handle
8	532 12 45-26	Button Plunger
11	532 13 98-65	Link Lift LH
12	532 13 98-66	Link Lift RH
13	532 12 46-70	Retainer Spring
15	532 17 32-88	Link Front
16	873 35 08-00	Nut Jam Hex 1/2-13 Unc
17	532 17 56-89	Trunnion Blk Zinc
18	873 80 08-00	Nut Lock W/wsh 1/2-13unc
19	532 13 98-68	Arm Suspension Rear
20	532 16 35-52	Retainer Spring
31	532 16 98-65	Bearing pvt. Lift
32	873 54 06-00	Nut Crownlock 3/8-24

NOTE: All component dimensions given in U.S. inches
1 inch = 25.4 mm

LIMITED WARRANTY

The Manufacturer warrants to the original consumer purchaser that this product as manufactured is free from defects in materials and workmanship. For a period of one (1) year from date of purchase by the original consumer purchaser, we will repair or replace, at our option, without charge for parts or labor incurred in replacing parts, any part which we find to be defective due to materials or workmanship. This Warranty is subject to the following limitations and exclusions.

1. This warranty does not apply to the engine. Please contact your nearest dealer where they will send the machine to the engine manufacturer.
2. Transportation charges for the movement of any power equipment unit or attachment are the responsibility of the purchaser. Transportation charges for any parts submitted for replacement under this warranty must be paid by the purchaser unless such return is requested by your dealer.
3. Battery Warranty: On products equipped with a Battery, we will replace, without charge to you, any battery which we find to be defective in manufacture, during the first ninety (90) days of ownership. After ninety (90) days, we will exchange the Battery, charging you 1/12 of the price of a new Battery for each full month from the date of the original sale. Battery must be maintained in accordance with the instructions furnished.
4. The Warranty period for any products used for rental or commercial purposes is limited to 90 days from the date of original purchase.
5. This Warranty applies only to products which have been properly assembled, adjusted, operated, and maintained in accordance with the instructions furnished. This Warranty does not apply to any product which has been subjected to alteration, misuse, abuse, improper assembly or installation, delivery damage, or to normal wear of the product.
6. Exclusions: Excluded from this Warranty are belts, blades, blade adapters, normal wear, normal adjustments, standard hardware and normal maintenance.
7. In case of any problem within the boundaries of this warranty, contact the nearest department store, indicate the model number, serial number and the date of purchase of your machine. This warranty does not apply to accidental damages. All implicit warranties are limited to the same time frames. Or contact:

E.M. Services
54 Rue Lambrechts
92400 Courbevoie
France
Telephone: (1) 46678078
Fax: (1) 46678095

THIS WARRANTY DOES NOT APPLY TO INCIDENTAL OR CONSEQUENTIAL DAMAGES. ANY IMPLIED WARRANTIES ARE LIMITED TO THE SAME TIME PERIODS STATED HEREIN.

The logo for Rally, featuring the word "Rally" in a bold, stylized, black font. The letters are thick and blocky, with a slight slant to the right. The 'R' is particularly large and prominent.