



**REPAIR PARTS MANUAL**  
**MODEL NO. RZGT18H46B**  
**Lawn Tractor**

---

**Rally**

# HOW TO USE THIS MANUAL

This manual is designed to provide the customer with a means to identify the parts on his/her tractor when ordering repair parts. The illustrations may or may not represent the actual assemblies; therefore, it is not recommended to use this manual as a guide to assemble or disassemble the tractor. Some hardware and parts are drawn larger in order to more readily identify them.

Each tractor has its own model number.

The model number for your tractor can be found on the fender under the seat.

When ordering parts, always give the following information:

- Product - "Lawn Tractor"
- Model Number - "RZGT18H46B"
- Part Number
- Part Description

## TABLE OF CONTENTS

<b>SCHEMATIC.....</b>	<b>3</b>
<b>ELECTRICAL.....</b>	<b>4-5</b>
<b>CHASSIS AND ENCLOSURES.....</b>	<b>6-7</b>
<b>DRIVE.....</b>	<b>8-9</b>
<b>STEERING.....</b>	<b>10-11</b>
<b>ENGINE.....</b>	<b>12</b>
<b>SEAT.....</b>	<b>13</b>
<b>DECALS.....</b>	<b>14</b>
<b>MOWER LIFT.....</b>	<b>15</b>
<b>MOWER DECK.....</b>	<b>16-17</b>
<b>WARRANTY.....</b>	<b>20</b>

# TRACTOR - - MODEL NUMBER RZGT18H46B

## SCHEMATIC

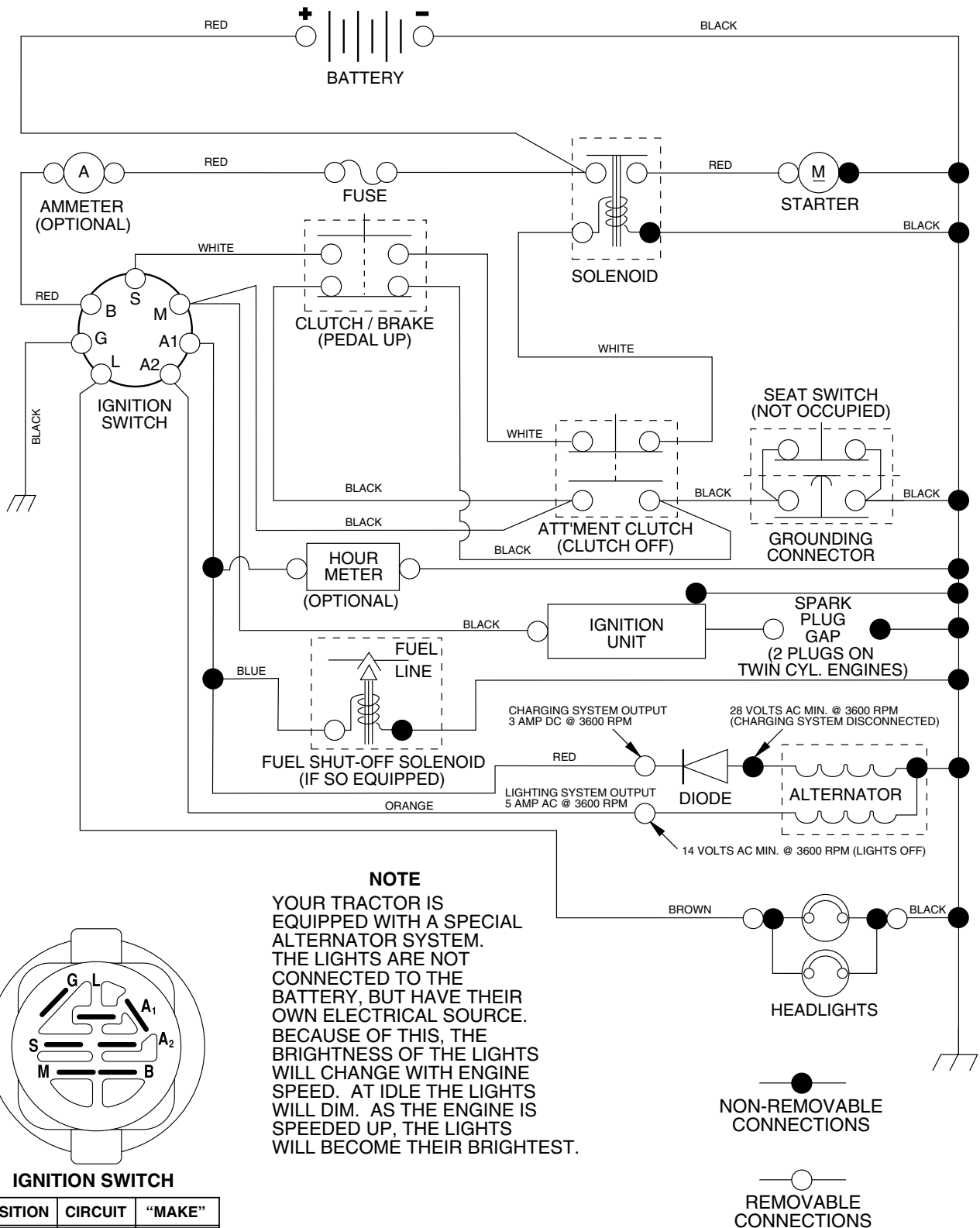

# REPAIR PARTS

## TRACTOR - - MODEL NUMBER RZGT18H46B

### ELECTRICAL

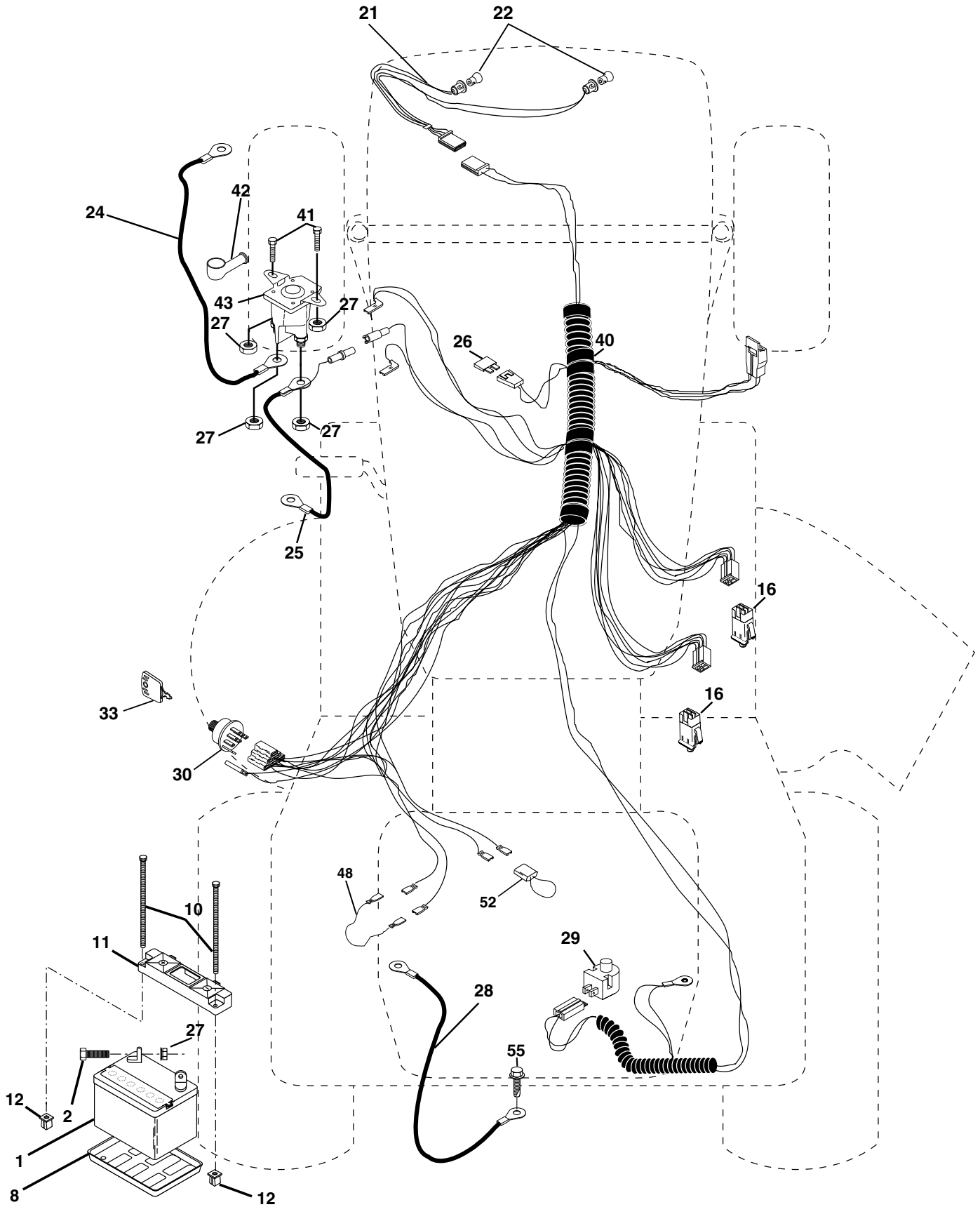

# REPAIR PARTS

## TRACTOR - - MODEL NUMBER RZGT18H46B

### ELECTRICAL

KEY NO.	PART NO.	DESCRIPTION
1	163465	Battery, 12 Volt, 28 Amp
2	74760412	Bolt, Hex Head 1/4-20 UNC x 3/4
8	7603J	Tray, Battery
10	145211	Bolt, Battery Front 1/4-20 x 7.5 Zinc
11	150109	Holddown Battery Dash Mount
12	145769	Nut, Push Nylon 1/4" Battery Front
16	153664	Switch Interlock Push-In
21	166181	Harness, Light
22	4152J	Bulb, Light
24	4799J	Cable, Battery, 6 Gauge, 11", Red
25	146148	Cable, Battery
26	175158	Fuse, 20 Amp
27	73510400	Nut, Hex, Keps 1/4-20 UNC
28	145491	Cable, Ground, 6 Gauge, 12", Black
29	121305X	Switch, Plunger
30	175566	Switch, Ignition, Push-In
33	140401	Key, Ignition
40	<b>178437</b>	Harness, Ignition
41	71110408	Bolt, Hex, Fin. 1/4-20 x 1/2
42	131563	Cover, Terminal, Red
43	178861	Solenoid
48	140844	Adapter Amm Rect.
52	141940	Protection Wire Loop
55	17490508	Screw, Thdrol 5/16-18 x 1/2 TYT

**NOTE:** All component dimensions given in U.S. inches  
1 inch = 25.4 mm

# REPAIR PARTS

## TRACTOR - - MODEL NUMBER RZGT18H46B

### CHASSIS

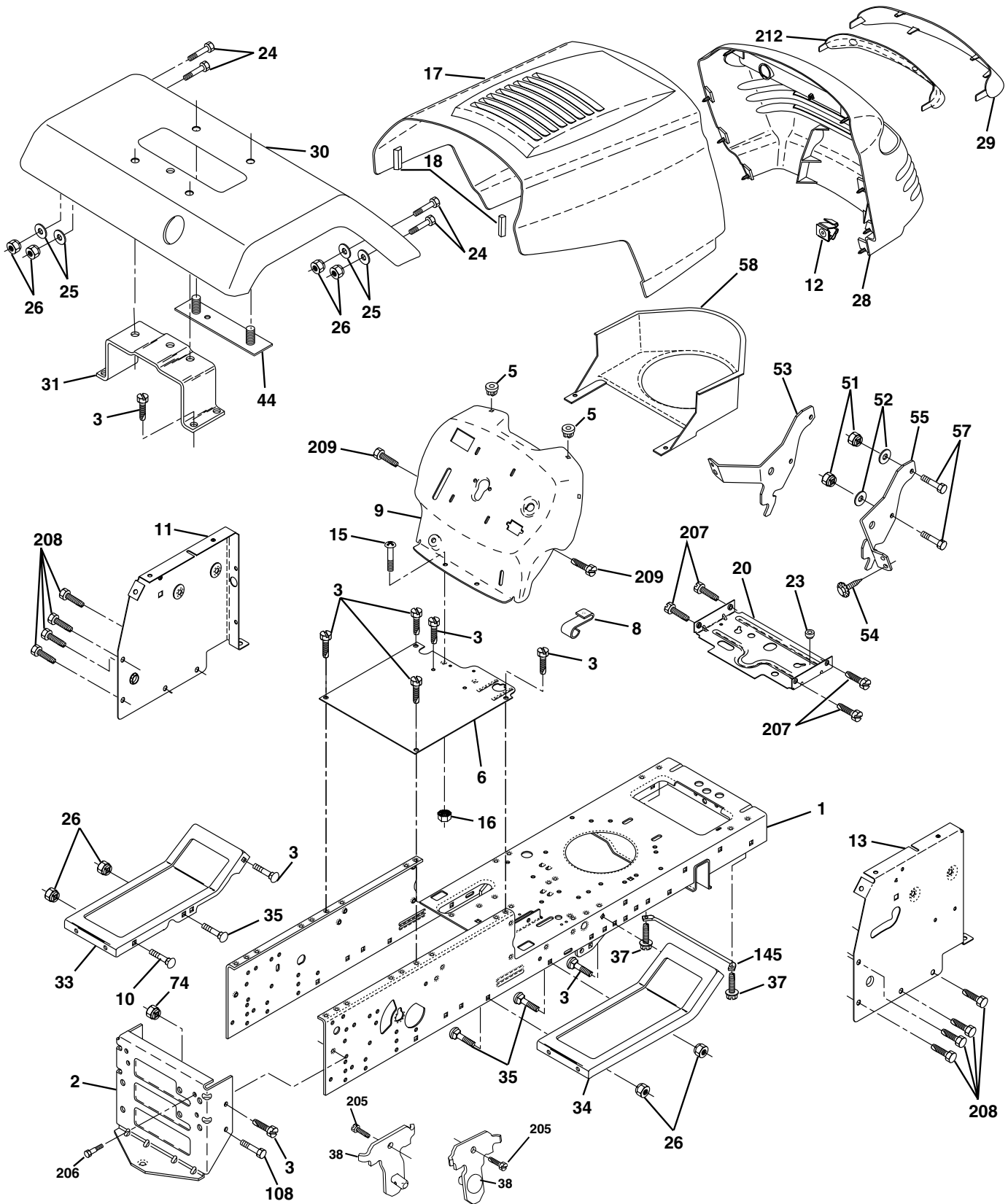

# REPAIR PARTS

## TRACTOR - - MODEL NUMBER RZGT18H46B

### CHASSIS

KEY NO.	PART NO.	DESCRIPTION
1	174620	Chassis
2	176554	Drawbar
3	17060612	Screw 3/8-16 x 3/4
5	155272	Bumper Hood/Dash
6	155923	Saddle Flat Lt
8	126471X	Clip Insulator
9	168347X011	Dash
10	72140608	Bolt RdHd Sqnk. 3/8-16 Unc x 1
11	156682	Panel Dash Lh
12	145660	Clip Tinnerman
13	172109	Panel Dash Rh
15	74180512	Screw 5/16-18 x 3/4
16	73510500	Nut Keps 5/16-18
17	159639X505	Hood
18	126938X	Bumper Hood
20	156437	Plate Mtg.
23	124028X	Bushing
24	74780616	Bolt Fin Hex 3/8-16 Unc x 1 Gr. 5
25	19131312	Washer 13/32 x 13/16 x 12 Ga.
26	73800600	Nut Lock Hex w/Insert 3/8-16 UNC
28	140434	Grill / Lens Asm
29	140273X599	Lens Grille
30	167270X505	Fender Asm YTGT
31	175315	Bracket Fender
33	145244X505	Footrest Pnt. Lh
34	145243X505	Footrest Pnt. Rh
35	72110606	Bolt RdHd Sht. Sqnk. 3/8-16 x 3/4
37	17490508	Screw Thdrol 5/16-18 x 1/2 Tyt
38	175710	Bracket Asm Pivot Mower Rear
44	140675	Strap Asm Fender
51	73800400	Nut Lock w/Ins 1/4-20
52	19091416	Washer 9/32 x 7/8 x 16 Ga.
53	144697	Bracket Grille LH
54	161464	Screw Hx 8-18 x 7/8
55	144696	Bracket Grille RH
57	74780412	Bolt FHX 1/4-20 x 3/4
58	174930	Duct Intake Air
74	73680600	Nut Crownlock 3/8-16 Unc
108	74760612	Bolt Fin Hex 3/8-16 Unc x 3/4
145	156524	Rod Pivot Chassis/Hood
205	17490608	Screw Thdrol 3/8-16 x 1/2
206	170165	Bolt Shoulder 5/16-18
207	17670508	Screw Thdrol 5/16-18 x 1/2
208	17670608	Screw Thdrol 3/8-16 x 1/2
209	17000612	Screw Hex wsh Thdrol 3/8-16 x 3/4
212	156229	Insert Lens Reflector
--	5479J	Plug

**NOTE:** All component dimensions given in U.S. inches  
1 inch = 25.4 mm

# REPAIR PARTS

## TRACTOR - - MODEL NUMBER RZGT18H46B

### DRIVE

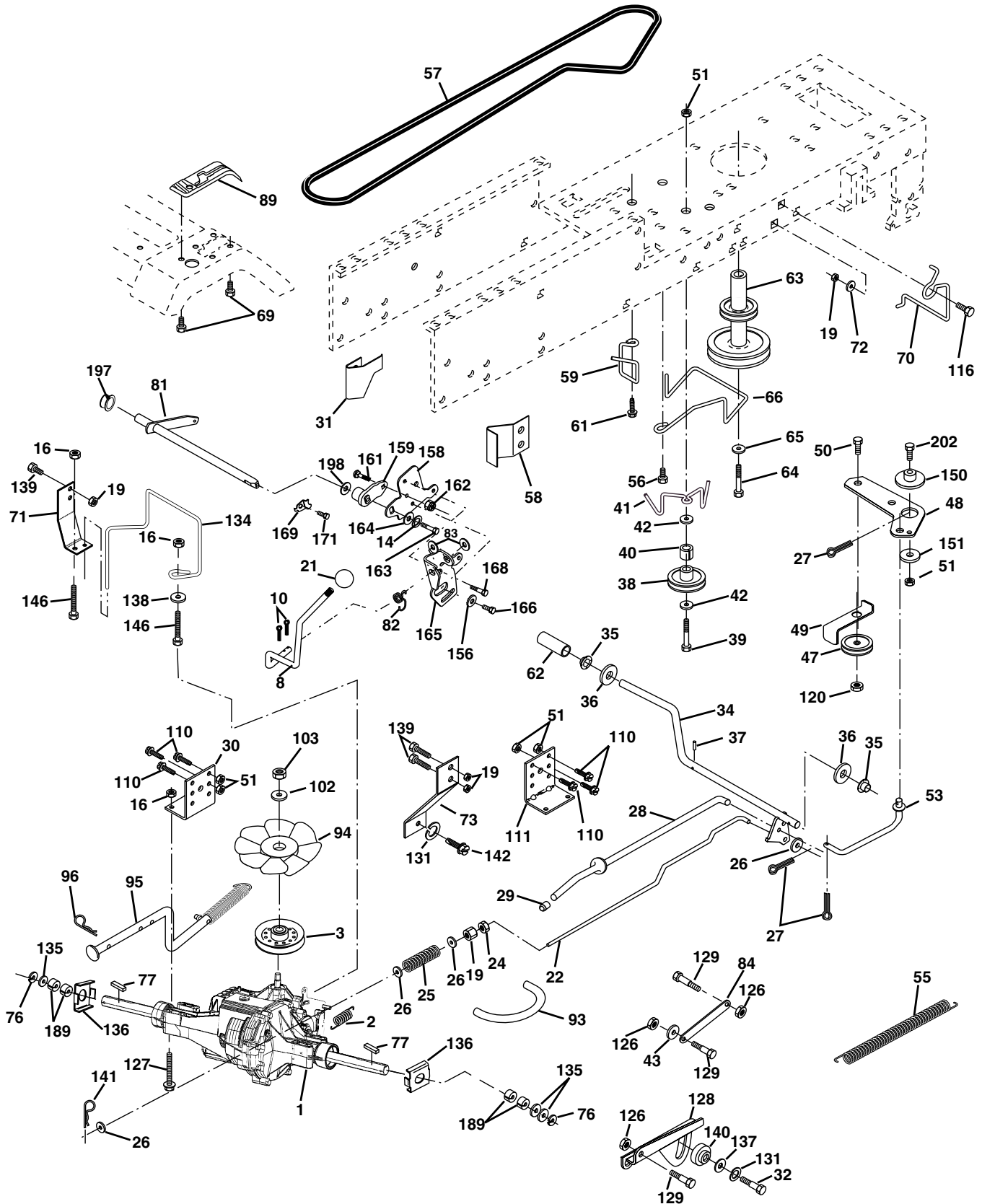



# REPAIR PARTS

## TRACTOR - - MODEL NUMBER RZGT18H46B

### DRIVE

KEY NO.	PART NO.	DESCRIPTION	KEY NO.	PART NO.	DESCRIPTION
1	-----	Transaxle, Hydro Gear Model 325-3000 (Order Parts From Transaxle Manufacturer)	77	9396E	Key Square 1/4 x 2
2	142431	Spring, Brake Return	81	165598	Shaft Asm Cross Tapered
3	143995	Pulley, Hydro	82	123782X	Spring, Torsion
8	166020	Rod Shift Fender Adjust Yt	83	19171216	Washer 17/32 x 3/4 x 16 Gauge
10	76020416	Pin, Cotter 1/8 x 1	84	165926	Link Transaxle
14	10040400	Washer Lock Hvy Helical	89	164892X428	Console
16	73800500	Nut Lock Hx w/Ins. 5/16-18 Unc	93	142564	Line Fuel Hydro
19	73800600	Nut, Lock Hex w/Ins. 3/8-16 UNC	94	140462	Fan Hydro
21	106933X	Knob	95	158508	Control Asm Bypass Hydro-3000
22	158274	Rod, Brake	96	4497H	Retainer Spring 1" Zinc/cad.
24	73350600	Nut, Hex Jam 3/8-16	102	141322	Washer Bellville 1/2 x 1-1/2
25	106888X	Spring, Rod, Brake	103	73940800	Nut Hex Jam Toplock 1/2-20 Unf
26	19131316	Washer 13/32 x 13/16 x 16 Ga.	110	74760612	Bolt Hex 3/8-16 x 3/4
27	76020412	Pin, Cotter 1/8 x 3/4	111	123776X	Bracket, Transaxle, R.H.
28	<b>175765</b>	Rod, Brake, Park	116	72110610	Bolt Rdhd Sq Neck 3/8-16 x 1/25
29	71673	Cap, Brake Parking Black	120	73900600	Nut Lock Flg. 3/8-16 Unc
30	123780X	Bracket, Transaxle, L.H.	126	1685H	Nut Lock 5/16-18 Nc Thd
31	123791X	Keeper, Belt, Transaxle, L.H.	127	74490548	Bolt Hex Flghd 5/16-18 x 3.0 Gr. 5
32	74760512	Bolt Hex Hd. 5/16-18 Unc x 3/4	128	158284	Bracket Neutral Adjust HG-3000
34	<b>175578</b>	Shaft, Foot Pedal	129	105529X	Bolt Shoulder 5/16-18 Unc
35	120183X	Bearing Nylon	131	10140500	Washer Lock 5/16
36	19211616	Washer 21/32 x 1 x 16 Gauge	134	158272	Rod Actuator Bypass Hydro-3000
37	1572H	Pin, Roll 3/16 x 1	135	123800X	Washer 1-1/32 x 1-5/8 x 16 Gauge
38	<b>165936</b>	Idler, Flat	136	163168X	Washer Axle Flange
39	<b>74760648</b>	Bolt Rdhd 3/8-16 Unc x 3	137	19111212	Washer 11/32 x 3/4 x 12 Ga.
40	<b>175461</b>	Spacer	138	19112016	Washer 11/32 x 1.25 x 16 Ga.
41	<b>175556</b>	Keeper, Idler	139	74760612	Bolt Fin Hex 3/8-16 x 3/4
42	19131312	Washer 13/32 x 13/16 x 12 Gauge	140	4475J	Bushing Pinion Sector
43	19111012	Bolt Shoulder 5/16-18 Unc	141	159197	Pin Hitch
47	127783	Pulley, Idler	142	74330516	Bolt 5/16 x 24 x 1
48	154407	Bellcrank Clutch Grnd Drv Stl	146	74490536	Bolt Hex Flghd 5/16-18 x 2-1/4
49	123205X	Retainer, Belt	150	<b>175456</b>	Spacer Retainer
50	74760624	Bolt, Hex 3/8-16 x 1-1/2	151	19133210	Washer 13/32 x 2 x 10 Ga.
51	73680600	Nut, Crownlock 3/8-16	156	166002	Washer Srrted 5/16ID x 1.125
53	105710X	Link, Clutch	158	165589	Bracket Shift Mount
55	105709X	Spring, Return, Clutch	159	165494	Hub Tapered Flange Shift Lt
56	74760620	Bolt, Hex 3/8-16 x 1-1/4	161	72140406	Bolt Rdhd Sqnk 1/4-20 x 3/4 Gr 5
57	161741	V-Belt, Drive	162	73680400	Nut Crownlock 1/4-20 Unc
58	158278	Keeper, Belt, Transaxle, R.H.	163	74780416	Bolt Hex Fin 1/4-20 Unc x 1 Gr 5
59	169691	Keeper Belt Centerspan	164	19091010	Washer 5/8 x .281 x 10 Ga
61	17060612	Screw 3/8-16 x 3/4	165	165623	Bracket Pivot Lever
62	8883R	Cover, Foot Pedal	166	166880	Screw 5/16-18 x 5/8
63	<b>175412</b>	Pulley, Engine	168	165492	Bolt Shoulder 5/16-18 x .561
64	71170764	Bolt, Hex 7/16-20 x 4-1/4	169	165581	Plate Fastening Lt
65	10040700	Washer, Lock Hvy Hlcl Spr 7/16	171	17490608	Screw Thdrol 3/8-16 x 1/2 Ty-Tt
66	161488	Keeper Belt Engine F-proof	189	160849	Washer Spacer Axle
69	142432	Screw Hex Wsh Hi-Lo 1/4-1/2 Unc	197	169613	Nyliner Snap-In 5/8" Id
70	162848	Keeper Belt Engine	198	169593	Washer Nyl 7/8 Id x .105
71	158283	Strap Torque Lh Hydro-3000	202	72110612	Bolt Carr Sh 3/8-16 x 1-1/2 Gr.5
72	19132012	Washer 13/32 x 1-1/4 x 12 Ga.			
73	158282	Strap Torque Rh Hydro-3000			
76	12000053	E-Ring			

**NOTE:** All component dimensions given in U.S. inches\  
1 inch = 25.4 mm

# REPAIR PARTS

## TRACTOR - - MODEL NUMBER RZGT18H46B

### STEERING ASSEMBLY

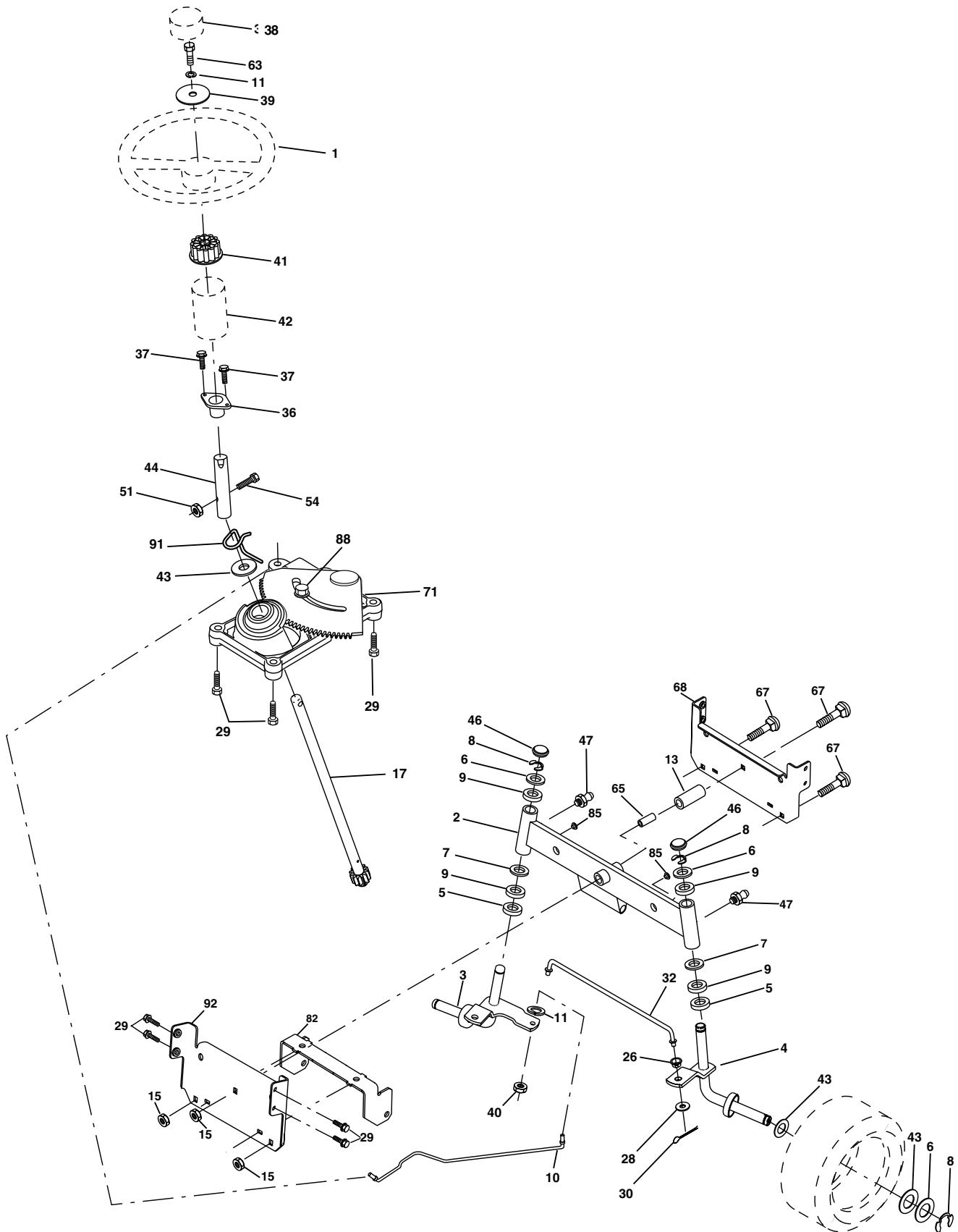

# REPAIR PARTS

## TRACTOR - - MODEL NUMBER RZGT18H46B

### STEERING ASSEMBLY

KEY NO.	PART NO.	DESCRIPTION
1	140044X428	Wheel Steering Auto Black
2	154427	Axle Asm Front
3	156486	Spindle Asm Lh
4	157475	Spindle Asm Rh
5	6266H	Bearing Race Thrust Harden
6	121748X	Washer 25/32 X 1 5/8 X 16ga
7	19272016	Washer 27/32 X 1 1/4 X 16 Ga
8	12000029	Ring Klip #t5304-75
9	3366R	Bearing Col Strg Blk
10	<b>175122</b>	Link Drag
11	10040600	Lockwasher
13	136518	Spacer Bearing Axle Front
15	145212	Nut Hex Flange Lock
17	<b>177876</b>	Shaft Asm Strg
26	126847X	Bushing Rod Tie Blk Lt
28	19131416	Washer 13/32 X 7/8 X 16ga
29	17060612	Screw 3/8-16x3/4
30	76020412	Pin
32	130465	Rod Tie Wire Form 19 75 Mech
36	155099	Bushing Strg
37	152927	Screw TT #10-32 x 5 x 3/8 Flange
38	140045X428	Insert Cap Strg
39	19133812	Washer 13/32 x 2 3/8 x 12
40	7810H	Locknut Center
41	100711L	Adaptor Wheel Strg 640/ 635id
42	145054X428	Boot Dash Steering
43	121749X	Washer 25/32 X 1 1/4 X 16 Ga
44	153720	Extension Steering
46	121232X	Cap Spindle Fr Top Blk
47	6855M	Fitting Grease
51	73800500	Nut Lock Hx w/Ins 5/16-18
54	74780520	Bolt Fin Hx. 5/16-18 x 1-1/4
63	74780616	Bolt Fin Hx. 3/8-16 x 1
65	160367	Spacer Axle
67	72140618	Bolt Rdhd Sq 3/8-16 Unc x 2-1/4
68	169828	Brace Axle Front
71	<b>175146</b>	Steering Asm
82	169835	Bracket Susp Chassis Front
85	133835	Fastner Christmas Tree
88	<b>175118</b>	Bolt Shoulder 7/16-20 Unc
91	<b>175553</b>	Clip Steering
92	169829	Axle Rear 16" Tires GTV

**NOTE:** All component dimensions given in U.S. inches  
1 inch = 25.4 mm

# REPAIR PARTS

## TRACTOR - - MODEL NUMBER RZGT18H46B

### ENGINE

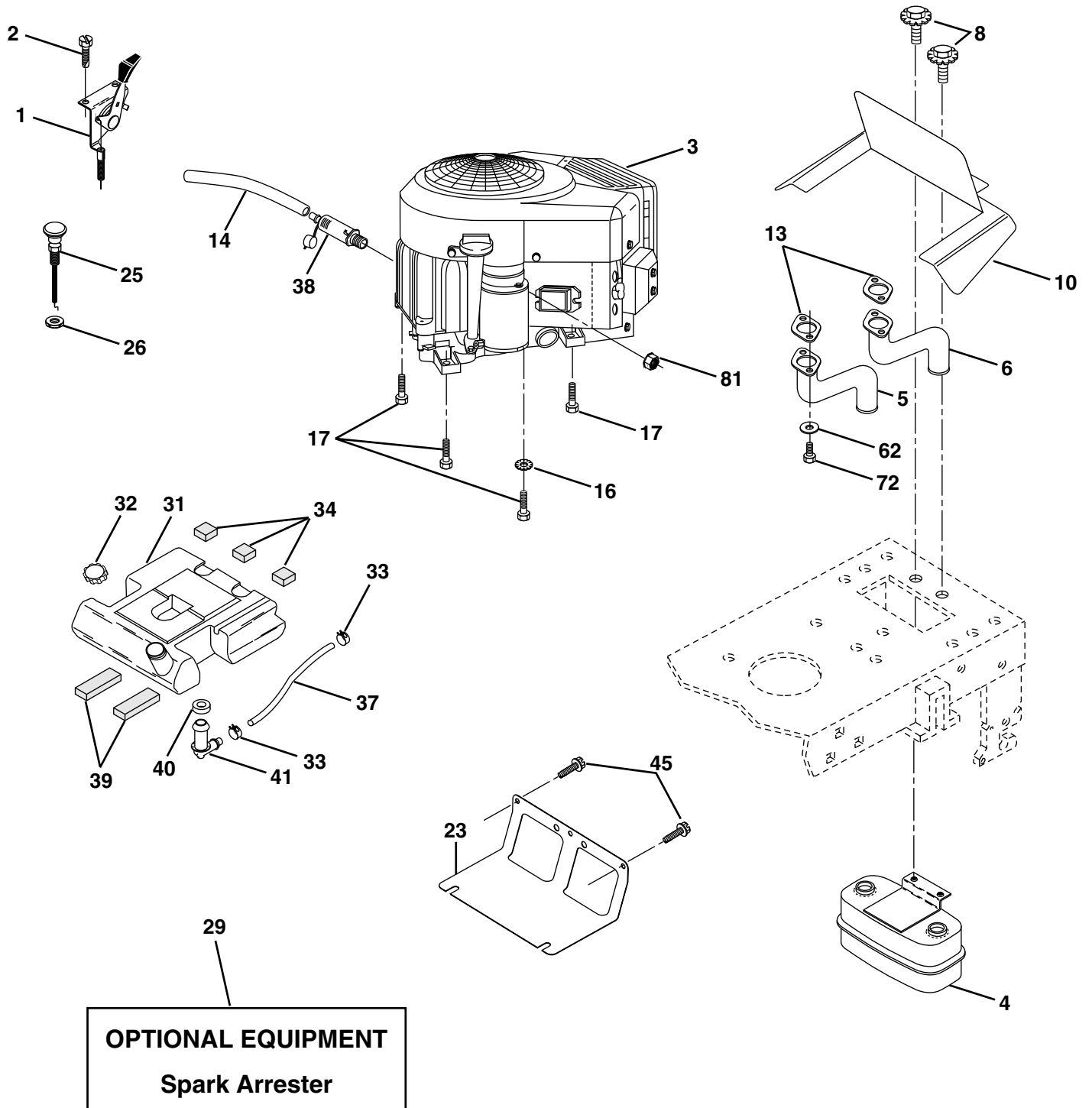

# REPAIR PARTS

## TRACTOR - - MODEL NUMBER RZGT18H46B

### ENGINE

KEY NO.	PART NO.	DESCRIPTION
1	170771	Control, Throttle
2	17720410	Screw, Hex Head, Thread Cutting 1/4-20 x 5/8
3	-----	Engine, Model Number B&S 407777 (Order Parts From Engine Manufacturer)
4	149723	Muffler
5	159955	Tube, Exhaust, LH
6	160589	Tube, Exhaust, RH
8	171877	Bolt 5/16-18 UNC x 3/4 w/Sems
10	162797	Shield, Browning
13	165391	Muffler Gasket
14	148456	Tube Drain Oil Easy
16	11050600	Washer, Lock, External Tooth 3/8
17	17490624	Screw hdrol 3/8-16 x 1 1/2
23	169837	Shield, Browning / Debris Guard
25	145996	Choke Control
26	73920600	Nut, Keps 3/8-24 UNF
29	137180	Kit, Spark Arrestor
31	151346	Tank Fuel 3 50 Rear
32	140527	Cap Fuel Gauge
33	123487X	Clamp, Hose
34	106082X	Pad, Spacer
37	8543R	Line, Fuel
38	148315	Plug Drain Oil Easy
39	109227X	Pad, Idler
40	3645J	Bushing
41	139277	Stem, Fuel Tank
45	17000612	Screw Hex wsh Thdrol 3/8-16 x 3/4
62	10040500	Washer Lock 5/16
72	71070512	Screw Hex Hd Cap 5/16-18 x 3/4
81	73510400	Nut Keps Hex 1/4-20 Unc

**NOTE:** All component dimensions given in U.S. inches.  
1 inch = 25.4 mm

# REPAIR PARTS

## TRACTOR - - MODEL NUMBER RZGT18H46B

### SEAT ASSEMBLY

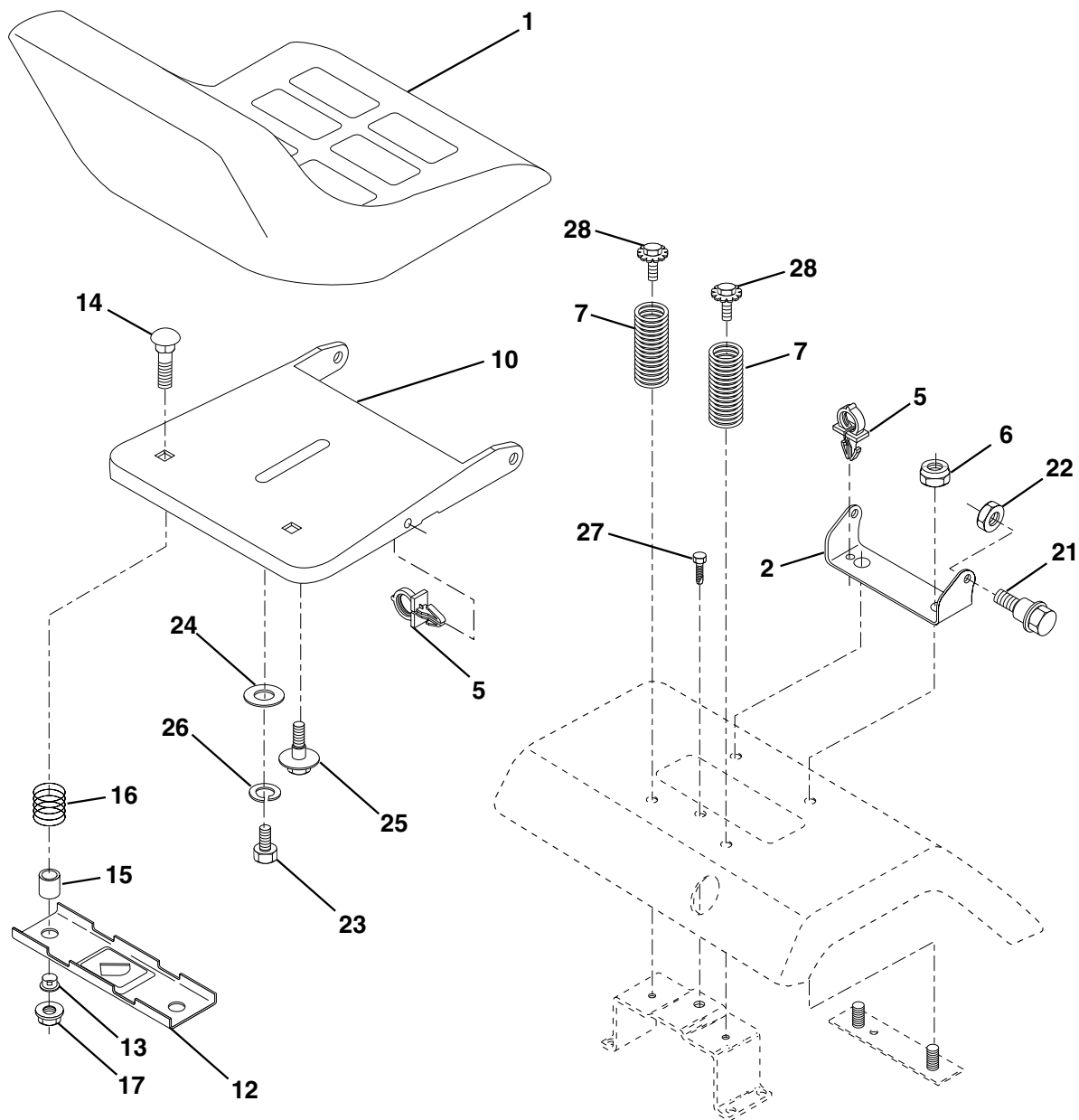

KEY NO.	PART NO.	DESCRIPTION
1	127428	Seat
2	140551	Pivot Bracket, Seat
5	145006	Clip, Push-in Hinged
6	73800600	Nut, Lock Hex w/Ins 3/8-16 UNC
7	124181X	Spring, Seat
10	174894	Pan, Seat
12	121246X	Bracket, Switch Mounting
13	121248X	Bushing, Snap, Black, Nylon
14	72050412	Bolt, Carriage 1/4-20 x 1-1/2
15	134300	Spacer, Split
16	121250X	Spring
17	123976X	Locknut, Flange 1/4 Grade 5

KEY NO.	PART NO.	DESCRIPTION
21	171852	Bolt, Shoulder 5/16-18 Unc -2A
22	73800500	Nut Lock Hex W/Ins 5/16-18 Unc
23	71110814	Bolt, Seat, Black
24	19171912	Washer 17/32 x 1-3/16 x 12 Gauge
25	127018X	Bolt, Shoulder 5/16-18 x .62
26	<b>10040800</b>	Washer Lock 1/2
27	17490608	Screw Thdrol 3/8-16 x 3/4
28	171877	Bolt 5/16-18 UNC x 3/4 w/Sems

**NOTE:** All component dimensions given in U.S. inches  
1 inch = 25.4 mm

# REPAIR PARTS

## TRACTOR - - MODEL NUMBER RZGT18H46B

### DECALS

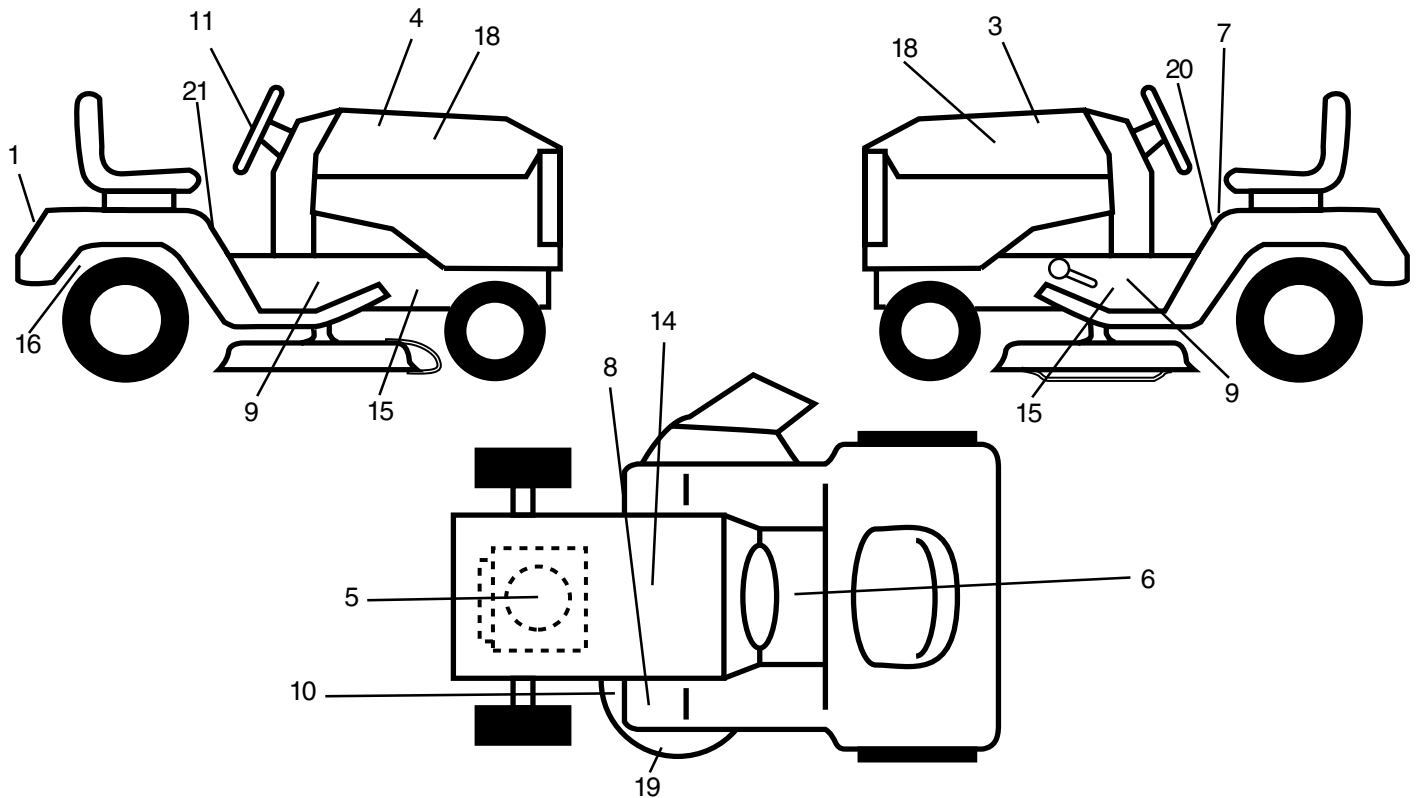

KEY NO.	PART NO.	DESCRIPTION
1	170752	Decal Fender
3	153267	Decal Hood LH
4	153266	Decal Hood RH
5	170850	Decal HP Engine
6	140837	Decal Parking Brake
7	145498	Decal Read Owners Manual
8	159737	Decal Clutch/brake Sym.
9	176676	Decal Chassis
10	139346	Decal V-Belt Sch
11	146902	Decal Steering
14	145005	Decal, Btry Dngr/Psn

KEY NO.	PART NO.	DESCRIPTION
15	159736	Decal Chassis Hot Muffler
16	162598	Decal Drawbar
18	176591	Decal Hood Insert
19	145494	Decal Deck Cut Finger
20	145437	Decal Europe
21	126187X	Decal 100DBA
--	142341	Decal Cntrl Movement
--	133671	Pad, Footrest
--	138311	Decal Handle Lft Height Adjust
--	177661	Manual, Operators, Euro
--	179002	Manual, Operators, Scan
--	179088	Manual, Repair Parts

### WHEELS & TIRES

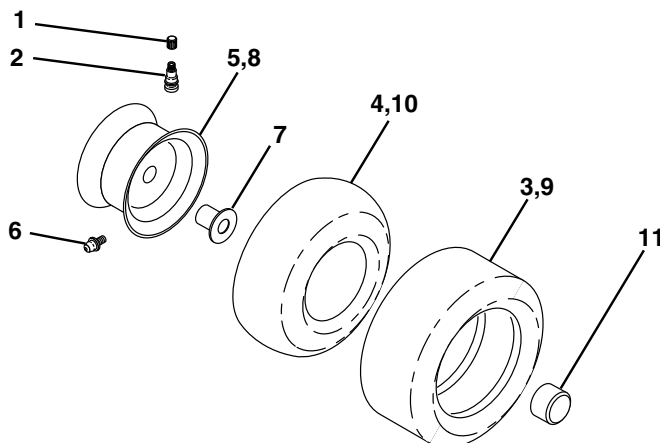

KEY NO.	PART NO.	DESCRIPTION
1	59192	Cap Valve Tire
2	65139	Stem Valve
3	106230X	Tire Front
4	59904	Tube Front (Service Item Only)
5	106228X427	Rim Asm 8" front
6	278H	Fitting Grease (Front Wheel Only)
7	9040H	Bearing Flange (Front Wheel nly)
8	124074X427	Rim Asm 12" rear
9	124106X	Tire R 23 x 8.5-12 C Service
10	7154J	Tube Rear (Service Item Only)
11	104757X428	Cap Axle Blk 1 50 X 1 00
--	144334	Sealant, Tire (1 Doz. Tube)

**NOTE:** All component dimensions given in U.S. inches  
1 inch = 25.4 mm

# REPAIR PARTS

TRACTOR - - MODEL NUMBER RZGT18H46B

## MOWER LIFT

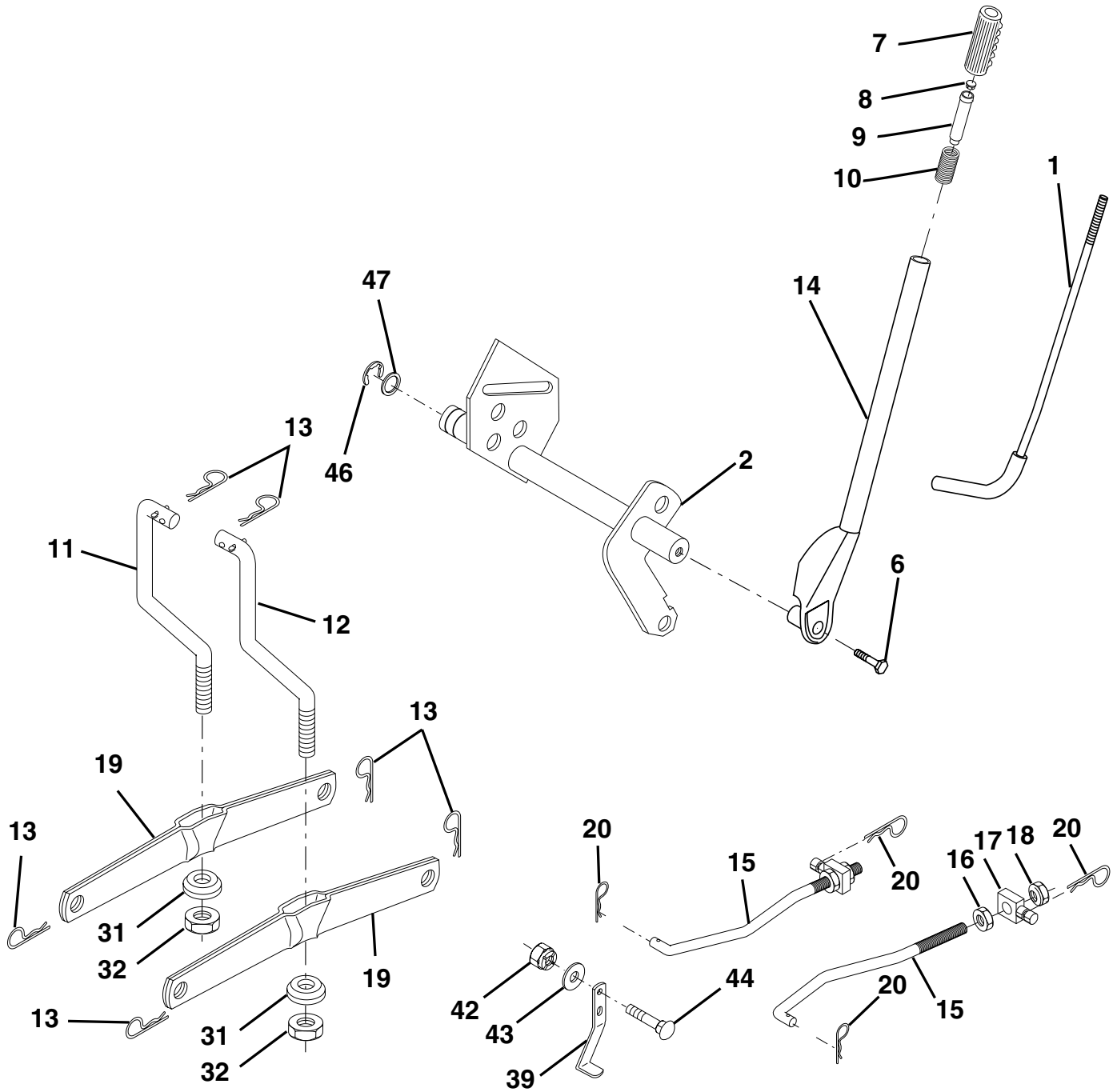



# REPAIR PARTS

## TRACTOR - - MODEL NUMBER RZGT18H46B

### MOWER LIFT

KEY NO.	PART NO.	DESCRIPTION
1	121006X	Rod Assembly, Lever
2	159188	Shaft Assembly, Lift
6	74780624	Bolt, Hex Head, Fin. 3/8-16 x 1-1/2
7	109413X	Grip Handle
8	124526X	Button Plunger Black
9	122364X	Plunger Lever Lift
10	2876H	Spring
11	145537	Link, Lift, LH
12	145536	Link, Lift, RH
13	4939M	Retainer Spring
14	159189	Lever Assembly, Lift, RH
15	173288	Link, Front
16	73350800	Nut, Hex, Jam 1/2-13 UNC
17	<b>175689</b>	Trunnion
18	73800800	Nut Lock W/Wsh 1/2-13 Unc
19	139868	Arm, Suspension, Rear
20	163552	Retainer Spring
31	169865	Bearing
32	73540600	Nut, Crownlock 3/8-24
39	142992	Stop Over Center
42	73680600	Nut, Crownlock 3/8-16 UNC
43	19131612	Washer 13/32 x 1 x 12 Ga.
44	72240608	Bolt, Carriage 3/8-16 x 1.00
46	12000022	E-Ring
47	19292016	Washer

**NOTE:** All component dimensions given in U.S. inches  
1 inch = 25.4 mm



# REPAIR PARTS

## TRACTOR - - MODEL NUMBER RZGT18H46B

### MOWER DECK

KEY NO.	PART NO.	DESCRIPTION	KEY NO.	PART NO.	DESCRIPTION
1	156948	Deck Asm., Mower 46"	48	139573	V-Belt, Mower, Primary
3	138457	Bracket Asm., Sway Bar	49	73680600	Nut, Crownlock 3/8-16 UNC
5	4939M	Retainer Spring	50	72110612	Bolt, Carriage 3/8-16 x 1-1/2 Gr. 5
6	130832	Arm, Suspension, Rear (Sway Bar)	52	156493	Pulley Idler
8	850857	Bolt, Patched 3/8-24 x 1-1/4 Gr. 8	58	165906	Rod Brake 46"
9	10030600	Washer, Lock Hvy., Unplated 3/8	59	157034	Guide Bolt 46" Mower Dr
10	140296	Washer, Hard Blade, Mower Vented	60	156722	Arm Asm Brake 46"
11	176084	Blade Hi-Perf 46"	61	161315	Bolt Shld 5/16-18
13	137553	Shaft Asm. w/Lower Bearing	62	131870	Spring Return
14	137152	Housing, Mandrel	67	106932X	Knob Rd 3/8-16 Plstc Thds Blk
15	110485X	Bearing, Ball, Mandrel	69	73350600	Nut Hex Jam 3/8-16 Unc
16	174493	Stripper, Mower Round	72	19131316	Washer 13/32 x 1 x 16 Ga.
18	72140505	Bolt, Carriage 5/16-18 x 5/8	82	4497H	Retainer Spring
19	132827	Bolt, Hex Head, Shoulder 5/16-18	85	10040600	Washer Lock 3/8
20	145055	Baffle, Vortex Mower 46"	116	4898H	Bolt, Shoulder
21	73680500	Nut, Crownlock 5/16-18 UNC	117	105455X	Gauge Wheel
22	134753	Stiffener, Bracket	118	73930600	Nut, Centerlock 3/8-16 UNC
23	131267	Bracket, Deflector	119	19121414	Washer 3/8 x 7/8 x 14 Ga.
24	105304X	Cap, Sleeve	120	19171512	Washer 17/32 x 15/16 x 12
25	149287	Spring, Torsion, Deflector	126	156472	Arm, Idler, Primary Deck 46"
26	110452X	Nut, Push	127	146763	Pulley, Idler, V-Groove Dim. 4.25
27	166883X428	Shield, Deflector Mower	129	19133808	Washer 13/32 x 2-3/8 x 8 Ga
28	19111016	Washer 11/32 x 5/8 x 16 Ga.	130	165891	Bolt Carriage Idler
29	131491	Rod, Hinge	132	165890	Arm Spring Brake Mower
30	157722	Screw, Thdroll Washer Head	133	165904	Bracket Anchor Cable 46"
31	129963	Washer, Spacer Mower Vented	134	17490512	Screw Thdroll 5/16-18 x 3/4
32	153531	Pulley, Mandrel	135	165898	Retainer Spring Yellow
33	<b>178342</b>	Nut, Flg. Top Lock	136	19091216	Washer 9/32 x 3/4 x 16 Ga
34	144945	Anchor, Spring Deck 46"	151	169670	Bracket Clutch Cable
35	17490628	Screw, Thdroll 3/8-16 x 1-3/4 Tytt	152	170328	Clutch Cable 38"/46"
36	19131316	Washer 13/32 x 1 x 16 Ga.	153	169674	Washer Flat 3/8" Type B
37	131494	Pulley, Idler, Flat	154	169675	Spring Retainer
38	156085	Keeper, Belt, Idler	155	169671	Spring Retension Q
39	144917	Pulley, Idler, Driven	156	169672	SPacer Clutch Cable
40	137273	Spring, Secondary 44/46/50 Vent	157	169669	Rod Clutch Cable 3/8"
41	17060620	Screw 3/8-16 x 1-1/4	158	17720410	Screw Hex Thd Cut 1/4-20 x 5/8
42	165723	Spacer, Retainer	--	143651	Mandrel Asm 44"/46"/50" Service
43	144949	Arm, Idler Secondary	--	172497	Replacement Mower Complete
44	133943	Washer, Hardened			
45	145059	Cover, Mandrel Deck			
46	137729	Screw, Thdroll. 1/4-20 x 5/8			
47	144959	V-Belt, Mower, Secondary			

**NOTE:** All component dimensions given in U.S. inches  
1 inch = 25.4 mm

## LIMITED WARRANTY

The Manufacturer warrants to the original consumer purchaser that this product as manufactured is free from defects in materials and workmanship. For a period of one (1) year from date of purchase by the original consumer purchaser, we will repair or replace, at our option, without charge for parts or labor incurred in replacing parts, any part which we find to be defective due to materials or workmanship. This Warranty is subject to the following limitations and exclusions.

1. This warranty does not apply to the engine. Please contact your nearest dealer where they will send the machine to the engine manufacturer.
2. Transportation charges for the movement of any power equipment unit or attachment are the responsibility of the purchaser. Transportation charges for any parts submitted for replacement under this warranty must be paid by the purchaser unless such return is requested by your dealer.
3. **Battery Warranty:** On products equipped with a Battery, we will replace, without charge to you, any battery which we find to be defective in manufacture, during the first ninety (90) days of ownership. After ninety (90) days, we will exchange the Battery, charging you 1/12 of the price of a new Battery for each full month from the date of the original sale. Battery must be maintained in accordance with the instructions furnished.
4. The Warranty period for any products used for rental or commercial purposes is limited to 90 days from the date of original purchase.
5. This Warranty applies only to products which have been properly assembled, adjusted, operated, and maintained in accordance with the instructions furnished. This Warranty does not apply to any product which has been subjected to alteration, misuse, abuse, improper assembly or installation, delivery damage, or to normal wear of the product.
6. **Exclusions:** Excluded from this Warranty are belts, blades, blade adapters, normal wear, normal adjustments, standard hardware and normal maintenance.
7. In case of any problem within the boundaries of this warranty, contact the nearest department store, indicate the model number, serial number and the date of purchase of your machine. This warranty does not apply to accidental damages. All implicit warranties are limited to the same time frames. Or contact:

E.M. Services  
54 Rue Lambrechts  
92400 Courbevoie  
France  
Telephone: (1) 46678078  
Fax: (1) 46678095

THIS WARRANTY DOES NOT APPLY TO INCIDENTAL OR CONSEQUENTIAL DAMAGES. ANY IMPLIED WARRANTIES ARE LIMITED TO THE SAME TIME PERIODS STATED HEREIN.

# Rally