

YTH155

Spare parts
Ersatzteile
Pièces détachées
Reserve onderdelen
Repuestos
Reservdelar

REPAIR PARTS

TRACTOR - MODEL NO. YTH155 (HEYTH155A), PRODUCT NO. 954 17 00-64
ELECTRICAL

KEY NO.	PART NO.	DESCRIPTION
1	532 16 34-65	Battery 12 Volt 28 AMP
2	874 76 04-12	Bolt Hex Hd 1/4-20unc X 3/4
8	532 17 66-89	Battery Box
16	532 17 61-38	Switch Interlock Push-In
21	532 16 61-81	Harness Asm Light W/4152j
22	532 00 41-52	Bulb Light #1156
24	532 12 47-80	Cable Battery 6 Ga 11" red
25	532 14 61-47	Cable Battery 6 Ga 44" red w/16 wire
26	532 17 51-58	Fuse 20 AMP
27	873 51 04-00	Nut Keps Hex 1/4-20 UNC
28	532 12 47-73	Cable Ground 6 Ga 12" black
29	532 12 13-05	Switch Plunger Nc Gray
30	532 17 55-66	Switch Ign
33	532 14 04-01	Key Ign Molded Generic
40	532 17 97-20	Harness Ign.
41	871 11 04-08	Bolt Blk Fin Hex 1/4 - 20 x 1/2
42	532 13 15-63	Cover Terminal Red
43	532 17 88-61	Solenoid
48	532 14 08-44	Adapter Ammeter Rectangular
52	532 14 19-40	Protection Wire Loop
89	532 18 04-49	Cover Terminal Battery

NOTE: All component dimensions given in U.S. inches.
1 inch = 25.4 mm.

REPAIR PARTS

TRACTOR - MODEL NO. YTH155 (HEYTH155A), PRODUCT NO. 954 17 00-64
CHASSIS AND ENCLOSURES

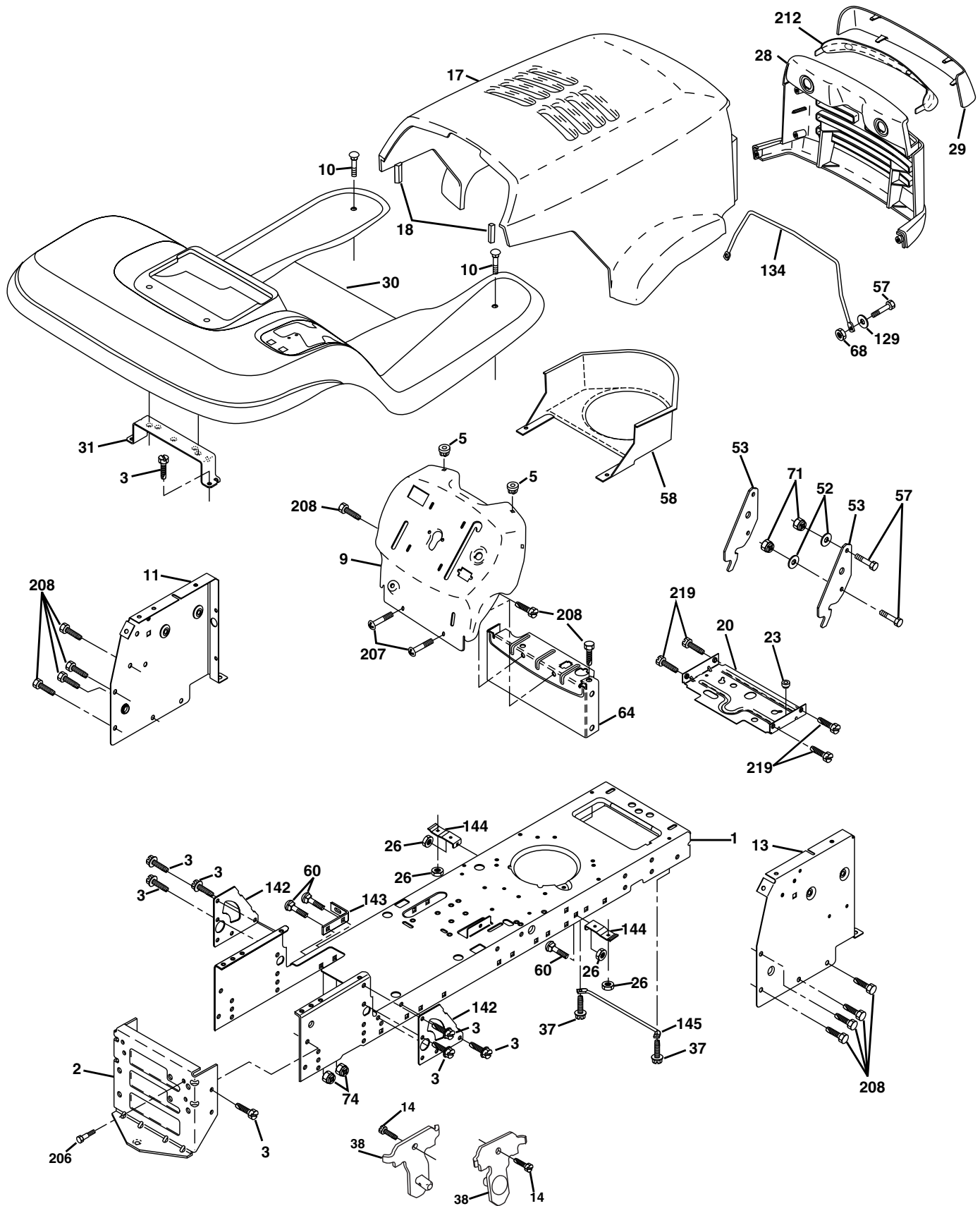

REPAIR PARTS

TRACTOR - MODEL NO. YTH155 (HEYTH155A), PRODUCT NO. 954 17 00-64 CHASSIS AND ENCLOSURES

KEY NO.	PART NO.	DESCRIPTION
1	532 17 46-19	Chassis Stamping
2	532 17 65-54	Drawbar
3	817 06 06-12	Screw 3/8-16x3/4
5	532 15 52-72	Bumper Hood/Dash
9	532 17 18-53	Dash P/L M
10	872 14 06-08	Bolt Carriage 3/8-16 x 1
11	532 17 49-96	Panel Dash Lh
13	532 17 21-06	Panel Dash Rh
14	817 49 06-08	Screw Thdrol 3/8-16 x 1/2
17	532 16 53-78	Hood LT/PL Husqvarna
18	532 12 69-38	Bumper Hood
20	532 18 06-79	Plate Mtg Battery Fuel Tank Fr
23	532 12 40-28	Bushing
26	873 80 06-00	Nut Lock Hex W/Ins 3/8-16 Unc
28	532 16 53-79	Grille LT/PL Husqvarna
29	532 16 53-80	Lens LT/PL Husqvarna
30	532 18 05-07	Fender Footrest STLT Pnt
31	532 13 99-76	Bracket Support Fender
37	817 49 05-08	Screw Thdrol 5/16-18 x 1/2 TYT
38	532 17 57-10	Bracket Asm Pivot Mower Rear
52	819 09 14-16	Washer 9/32 x 7/8 x 16 Ga.
53	532 15 00-67	Bracket Pnt. Pick off LT/PL Husqvarna
57	874 78 04-12	Bolt Hex 1/4-20 x 3/4
58	532 15 01-27	Air Duct Engine P/L
60	872 14 06-06	Bolt Rdhd Sqnk 3/8-16unc x 3/4
64	532 15 47-98	Dash Lower STLT
68	873 51 04-00	Nut Keps Hex 1/4-20 Unc
71	873 68 04-00	Nut Crownlock 1/4-20 Unc
74	873 68 06-00	Nut Crownlock 3/8-16 UNC
129	819 09 10-16	Washer 9/32 x 5/8 x 16 Ga.
134	532 16 02-19	Rod Support Hood LT/PL Husq.
142	532 17 57-02	Plate Reinforcement STLT
143	532 15 49-66	Bracket Swaybar Chassis
144	532 17 55-82	Bracket Pnt Footrest STLT
145	532 15 65-24	Rod Pivot Chassis/Hood
206	532 17 01-65	Bolt Shoulder 5/16-18 TT
207	817 67 05-08	Screw Thdrol 5/16-18 x 1/2 TYTT
208	817 67 06-08	Screw Thdrol 3/8-16 x 1/2 TYT BI
212	532 15 61-95	Insert Lens Reflect
219	817 00 05-12	Screw 5/16-18 x 3/4
--	532 00 54-79	Plug Button

NOTE: All component dimensions given in U.S. inches
1 inch = 25.4 mm

REPAIR PARTS

TRACTOR - MODEL NO. YTH155 (HEYTH155A), PRODUCT NO. 954 17 00-64
DRIVE

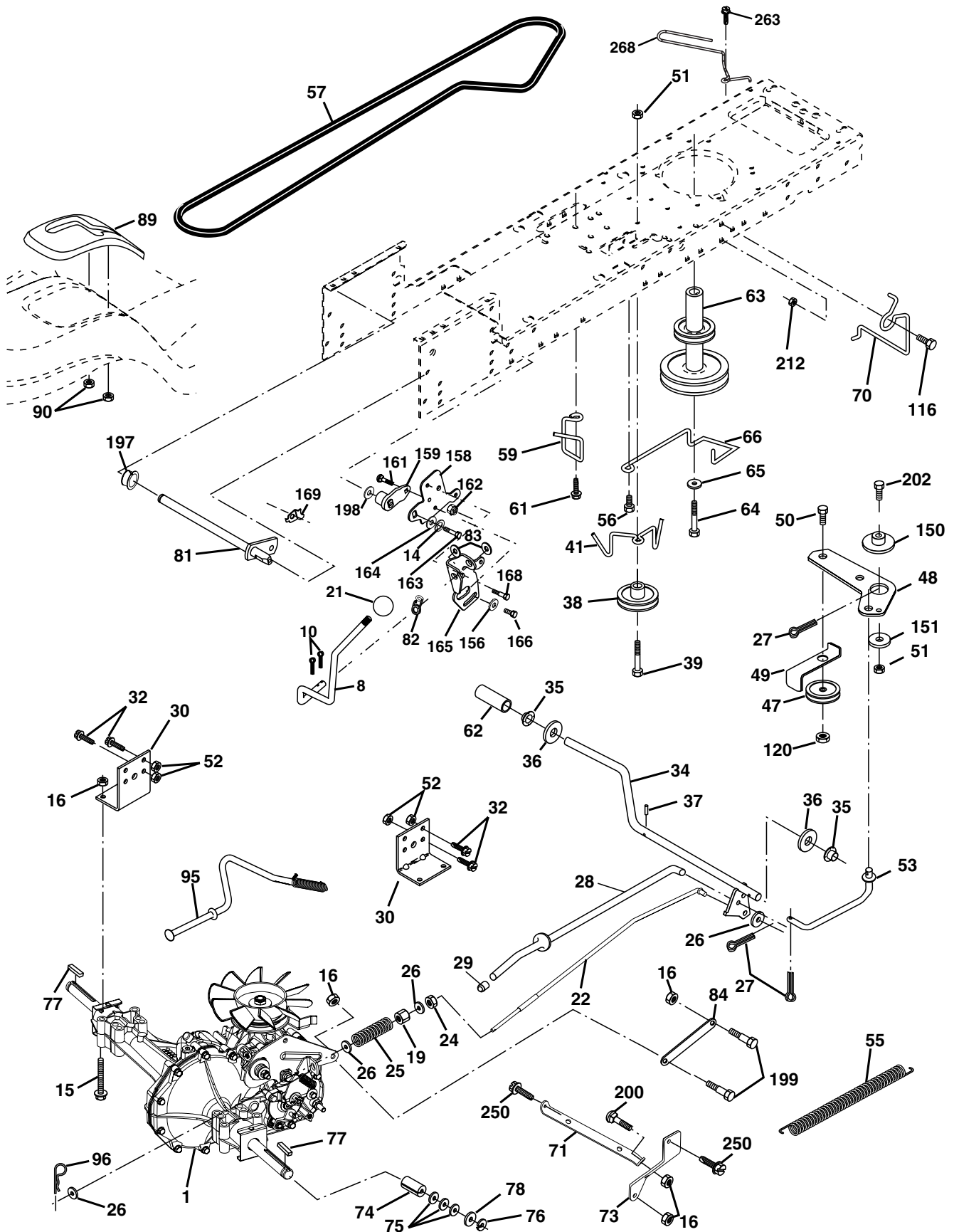

REPAIR PARTS

**TRACTOR - MODEL NO. YTH155 (HEYTH155A), PRODUCT NO. 954 17 00-64
DRIVE**

KEY NO.	PART NO.	DESCRIPTION	KEY NO.	PART NO.	DESCRIPTION
1	-----	Transaxle Hydro Gr 314-0510 (Order parts from transaxle manufacturer)	70	532 18 02-18	Guide Belt Mower Drive RH
8	532 16 58-66	Rod Shift Fender STLT	71	532 16 91-83	Strap Torque Lh Hydro
10	876 02 04-16	Pin Cotter 1/8 x 1 CAD	73	532 16 91-82	Strap Torque Rh Hydro
14	810 04 04-00	Washer Lock Hvy Helical 1/4	74	532 13 70-57	Spacer, Axle
15	874 49 05-44	Bolt Hex Flg Hd 5/16-18 X Gr.5	75	532 12 17-49	Washer 25/32 x 1-1/4 x 16 Gauge
16	873 80 05-00	Nut Lock Hex W/Ins. 5/16-18 Unc P	76	812 00 00-01	E-Ring
19	873 80 06-00	Nut Lock Hex W/Wsh 3/8-16 Unc	77	532 12 35-83	Key, Square
21	532 12 12-74	Knob, Duckhead	78	532 12 17-48	Washer 25/32 x 1-5/8 x 16 Gauge
22	532 16 94-98	Rod, Brake Hydro	81	532 16 55-96	Shaft Asm. Cross Hydro
24	873 35 06-00	Nut	82	532 16 57-11	Spring Torsion T/A
25	532 10 68-88	Spring, Brake Rod	83	819 17 12-16	Washer 17/32 x 3/4 x 16 Ga.
26	819 13 13-16	Washer	84	532 16 95-94	Link Transaxle
27	876 02 04-12	Pin Cotter 1/8 x 3/4 CAD.	89	532 16 65-10	Console, Shift
28	532 17 57-65	Rod, Parking Brake	90	532 12 43-46	Nut Self-Thd wsh-Hd 1/4 Zinc
29	532 07 16-73	Cap, Parking Brake	95	532 17 02-01	Control Asm Bypass Hydro
30	532 16 95-92	Bracket, Transaxle	96	532 12 47-88	Retainer Spring 1" Zinc/Cad
32	874 76 05-12	Bolt Hex Hd 5/16-18 Unc x 3/4	116	872 14 06-08	Bolt 3/8-16 Unc x 1
34	532 17 55-78	Shaft, Foot Pedal	120	873 90 06-00	Nut Lock 3/8-16 Unc
35	532 12 01-83	Bearing, Nylon	150	532 17 54-56	Spacer Retainer
36	819 21 16-16	Washer	151	819 13 32-10	Washer 13/32 x 2 x 10 Ga.
37	532 12 49-63	Pin, Roll	156	532 16 60-02	Washer Srrtd 5/16 ID x 1.0 x .125 Tk
38	532 17 91-14	Pulley, Idler, Composite	158	532 16 55-89	Bracket Shift Mount
39	874 76 06-48	Bolt Fin Hex 3/8-16 Unc x 2-3/4	159	532 16 54-94	Hub Tapered Flange Shift LT
41	532 17 55-56	Keeper, Belt Idler	161	872 14 04-06	Bolt Rdhd Sqnk 1/4-20 x 3/4 Gr. 5
47	532 12 77-83	Pulley, Idler, V-Groove	162	873 68 04-00	Nut Crownlock 1/4-20 Unc
48	532 15 44-07	Bellcrank Clutch Grnd Drv Stl	163	874 78 04-16	Bolt Hex Fin 1/4-20 unc x 1 Gr. 5
49	532 12 32-05	Retainer, Belt	164	819 09 10-10	Washer 5/8 x .281 x 10 Ga
50	872 11 06-12	Bolt Hex 3/8-16 Unc x 1-1/2	165	532 16 56-23	Bracket Pivot Lever
51	873 68 06-00	Nut Crownlock 3/8-16	166	532 16 68-80	Screw 5/16-18 x 5/8 TT Yellow
52	873 68 05-00	Nut Crownlock 5/16-18	168	532 16 54-92	Bolt Shoulder 5/16-18 x .561 TT
53	532 10 57-10	Link, Clutch	169	532 16 55-80	Plate Fastening Cross Shf. STLT/CRD
55	532 10 57-09	Spring, Return, Clutch	197	532 16 96-13	Nyliner Snap-In 5/8" ID
56	817 06 06-12	Screw 3/8-16 x .75	198	532 16 95-93	Washer Nyl 7/8 ID x .105 HYD CRD
57	532 14 02-94	V-Belt, Ground Drive	199	532 16 96-12	Bolt Shoulder 5/16-18 Unc
59	532 16 96-91	Keeper, Center Span	200	872 14 05-08	Bolt Rdhd Sqnk 5/16-18 Unc x 1
61	817 12 06-14	Screw 3/8-16 x .875	202	872 11 06-14	Bolt Carr Sh 3/8-16 x 1-3/4 Gr. 5
62	532 12 35-33	Cover, Pedal	212	532 14 52-12	Nut Hexflange Lock
63	532 18 02-19	Pulley, Clutch Eng	250	817 06 06-12	Screw 3/8-16 x .75
64	871 17 07-64	Bolt Hex 7/16-20 x 4 Ga. 5	263	817 00 06-12	Screw Hex Wsh Thdr 3/8-16 x 3/4
65	810 04 07-00	Washer	268	532 18 24-02	Guard Muffler
66	532 15 47-78	Keeper Belt Engine			

NOTE: All component dimensions given in U.S. inches
1 inch = 25.4 mm

REPAIR PARTS

TRACTOR - MODEL NO. YTH155 (HEYTH155A), PRODUCT NO. 954 17 00-64
STEERING ASSEMBLY

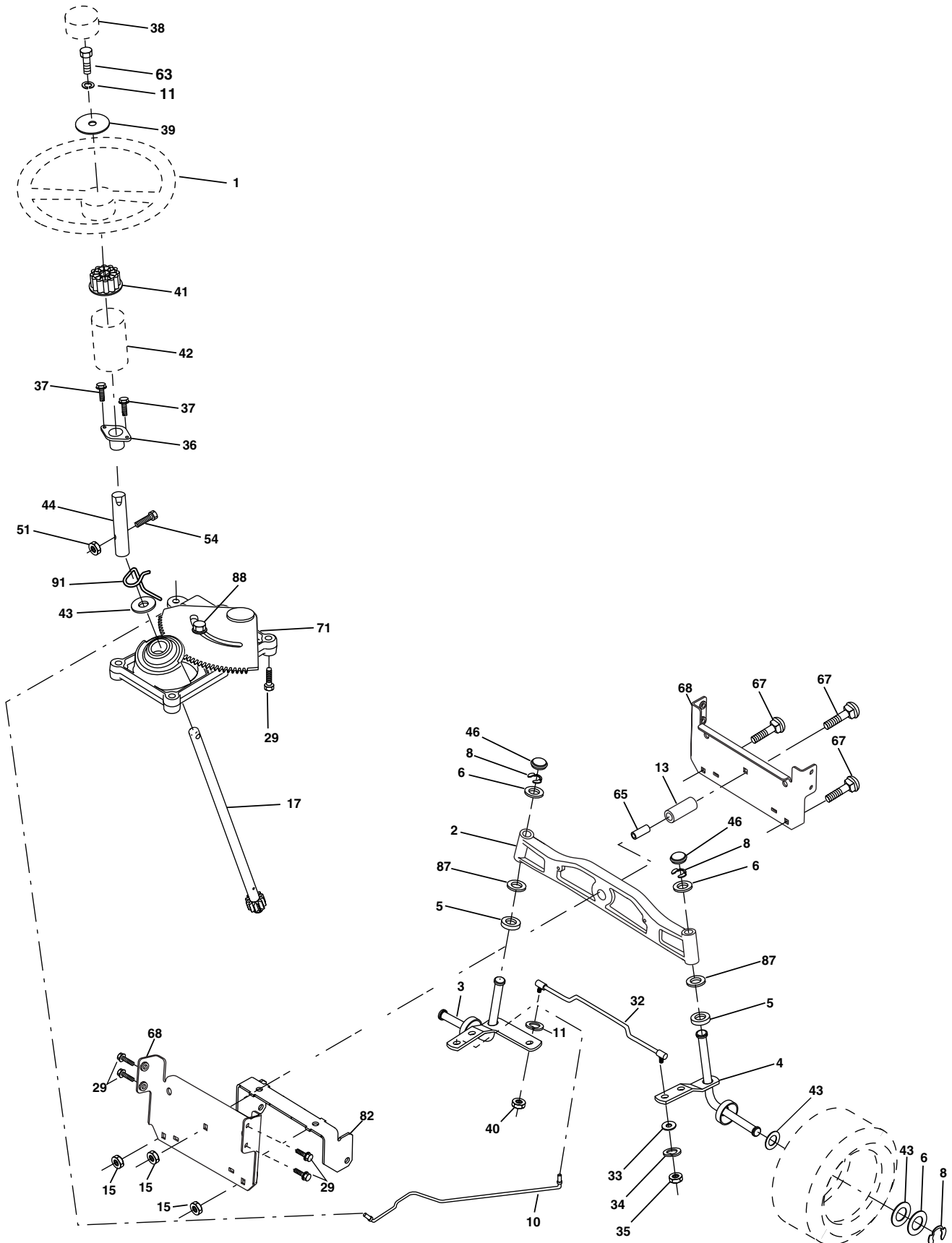

REPAIR PARTS

TRACTOR - MODEL NO. YTH155 (HEYTH155A), PRODUCT NO. 954 17 00-64
STEERING ASSEMBLY

KEY NO.	PART NO.	DESCRIPTION
1	532166627	Wheel Steering
2	532172393	Axle Cast Lt Machined
3	532169840	Spindle Asm LH
4	532169839	Spindle Asm RH
5	532124931	Bearing Race Thrust Harden
6	532121748	Washer 25/32 X 1-5/8 X 16 Ga
8	812000029	Ring Klip #t5304-75
10	532175121	Link Drag
11	810040600	Washer Lock Hvy Hlcl Spr 3/8
13	532136518	Spacer Brg Axle Front
15	532145212	Nut Hex Flange Lock
17	532177876	Shaft Asm Strg
29	817060612	Screw 3/8-16x3/4
32	532171888	Rod Tie
33	819111216	Washer 11/32 x 3/4 x 16 Ga.
34	810040500	Washer Lock Hvy Helical 5/16
35	873540500	Nut Crown Lock 5/16-24Unf
36	532155099	Bushing Strg
37	532152927	Screw
38	532166626	Insert Cap Strg Wh
39	819132411	Washer 13/32 x 1-1/20 x 11 Ga
40	532124701	Lock nut
41	532159945	Adaptor Wheel Strg
42	532169634	Boot Steering Shaft
43	532121749	Washer 25/32 X 1 1/4 X 16 Ga
44	532153720	Extension Steering Shaft LR/LT
46	532121232	Cap Spindle Fr Top Blk
51	873800500	Nut Lock Hex w/Ins 5/16-18
54	874780520	Bolt Fin Hex 5/16-18 Unc x 1-1/4
63	874780616	Bolt Fin Hex 3/8-16unc x 1 Gr. 5
65	532160367	Spacer Brace Axle
67	872140618	Bolt Rdhd Sq 3/8-16 x 2-1/4
68	532169827	Axle, Brace
71	532175146	Steering Asm
82	532169835	Bracket Susp Chassis Front
87	532173966	Washer Flat .781 x 1-1/2 x .14
88	532175118	Bolt Shoulder 7/16-20
91	532175553	Clip Steering

NOTE: All component dimensions given in U.S. inches.
1 inch = 25.4 mm.

REPAIR PARTS

TRACTOR - MODEL NO. YTH155 (HEYTH155A), PRODUCT NO. 954 17 00-64
ENGINE

KEY NO.	PART NO.	DESCRIPTION
1	532 17 05-51	Control Th/ch Flag
2	817 72 04-08	Screw Hex Thd Cut 1/4-20x1/2
3	-----	Engine B&S Model No. 31G777 (Order Parts From Engine Manufacturer)
4	532 13 73-52	Muffler LT B&S 12/12.5/13HP
13	532 16 52-91	Gasket Eng 1 313 Id Tin Plated
14	532 14 84-56	Tube Drain Oil Easy
16	811 05 06-00	Washer Lock Ext Tooth 3/8
23	532 16 98-37	Shield Browning/Debris Guard
25	532 18 09-45	Control Choke
26	873 92 06-00	Nut Keps 3/8-24 Unf
29	532 13 71-80	Kit Spark Arrestor (Flat Scrn)
31	532 18 06-45	Tank Fuel Front 2 00 w/outlet
32	532 14 05-27	Cap Asm Fuel W/sym Vented
33	532 12 34-87	Clamp Hose Black
37	532 13 70-40	Line Fuel 20"
38	532 14 83-15	Plug Drain Oil Easy
40	532 12 40-28	Bushing Snap
41	532 13 92-77	Stem Tank Fuel
44	817 49 04-12	Screw Hexwsh Thdrol 1/4-20x3/4
45	817 00 06-12	Screw Hex Wsh Thdr 3/8-16 x 3/4
46	819 09 14-16	Washer 9/32 X 7/8 X 16 Ga
62	810 04 05-00	Washer Lock Hvy Hlcl Spr 5/16
72	871 07 05-12	Screw Hexhd Cap 5/16-18x 3/4
78	817 06 06-20	Screw 3/8-16x1-1/4 Smgml Tap/R
81	873 51 04-00	Nut Keps Hex 1/4-20 Starter Nut
112	532 12 49-52	Bushing

NOTE: All component dimensions given in U.S. inches
1 inch = 25.4 mm

REPAIR PARTS

TRACTOR - MODEL NO. YTH155 (HEYTH155A), PRODUCT NO. 954 17 00-64 SEAT ASSEMBLY

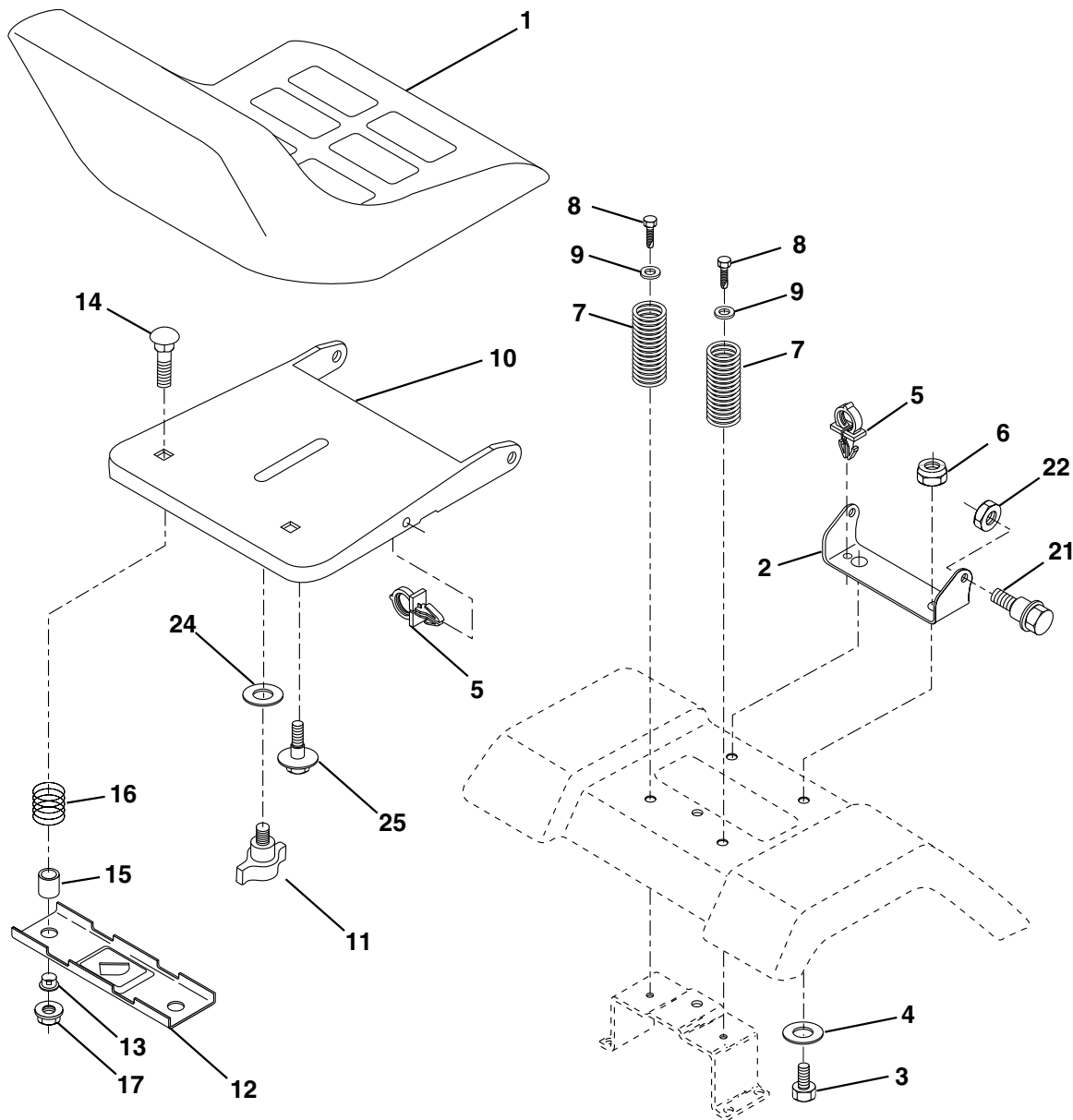

KEY NO.	PART NO.	DESCRIPTION
1	532 14 08-39	Seat
2	532 14 05-51	Bracket Pivot Seat 8 720
3	871 11 06-16	Bolt Fin Hex 3/8-16unc X 1
4	819 13 16-10	Washer 13/32 X 1 X 10 Ga
5	532 14 50-06	Clip Push-In
6	873 80 06-00	Nut Hex w/Ins. 3/8-16 Unc
7	532 12 41-81	Spring Seat Cprsn 2 250 Blk Zi
8	817 00 06-16	Screw 3/8-16 X 1-1/2 Smgml Tap/R Z
9	819 13 16-14	Washer 13/32 X 1 X 14 Ga.
10	532 18 24-93	Pan Seat
11	532 16 63-69	Knob Seat Adj. Wingnut
12	532 12 12-46	Bracket Mounting Switch

KEY NO.	PART NO.	DESCRIPTION
13	532 12 12-48	Bushing Snap Blk Nyl 50 Id
14	872 05 04-12	Bolt Rdhd Sqnk 1/4-20x1-1/2
15	532 13 43-00	Spacer Split 28x 96 Yel Zinc
16	532 12 12-50	Spring Cprsn 1 27 Blk Pnt
17	532 12 39-76	Nut Lock 1/4 Lge Flg Gr 5 Zinc
21	532 17 18-52	Bolt Shoulder 5/16-18 Unc-2a Blk DA
22	873 80 05-00	Nut Hex Lock W/Ins 5/16-18
24	819 17 19-12	Washer 17/32 X 1 3/16 x 12 Ga.
25	532 12 70-18	Bolt Shoulder 5/16-18 X 62

NOTE: All component dimensions given in U.S. inches.
1 inch = 25.4 mm

REPAIR PARTS

TRACTOR - MODEL NO. YTH155 (HEYTH155A), PRODUCT NO. 954 17 00-64
DECALS

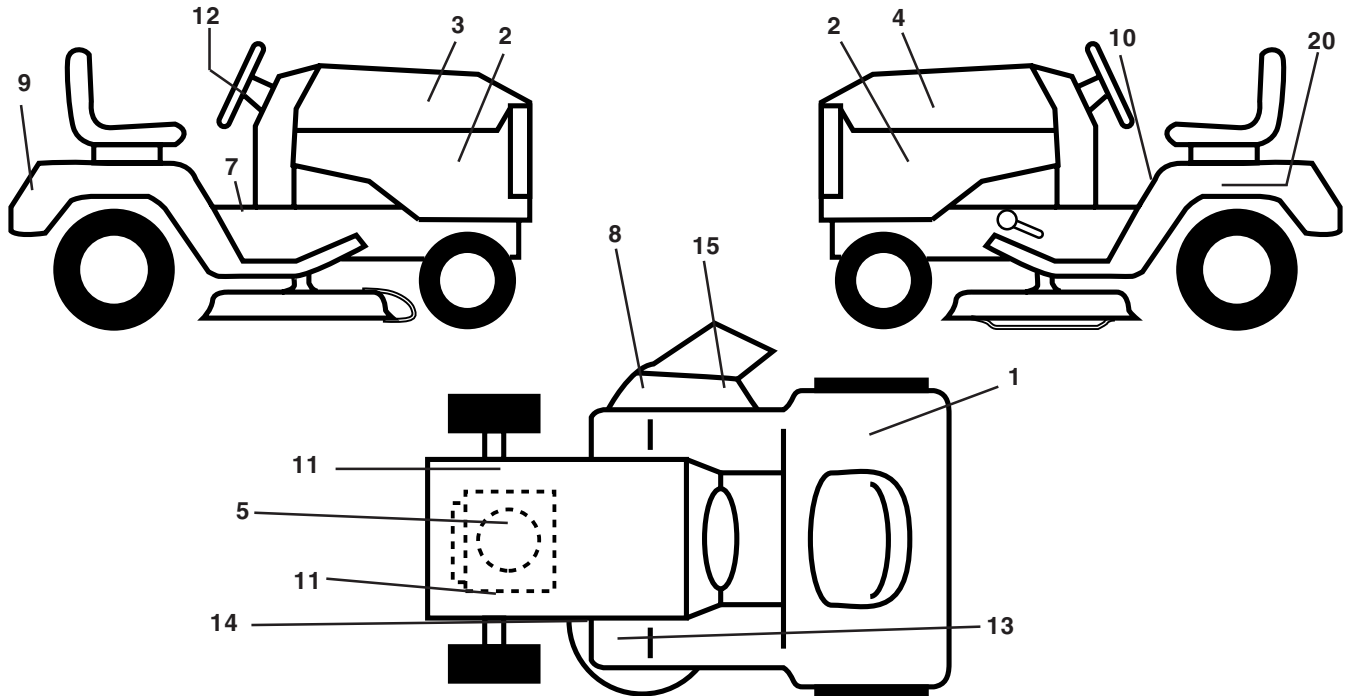

KEY NO.	PART NO.	DESCRIPTION	KEY NO.	PART NO.	DESCRIPTION
1	532 18 04-32	Decal 100 DB/CE	14	532 16 03-96	Decal V-Belt Schematic
2	532 15 97-13	Decal Panel Side B&S Logo	15	532 17 91-28	Decal Deck "B" 42"
3	532 17 96-61	Decal Hood RH	20	532 14 50-05	Decal Bat Dan/Psn
4	532 17 96-62	Decal Hood LH	--	532 16 25-98	Decal Drawbar Load Limit
5	532 18 04-34	Decal HP Engine	--	532 16 92-10	Decal By-Pass Lt Hydro
7	532 14 08-37	Decal Saddle Brake	--	532 17 12-84	Pad Footrest LH STLT
8	532 18 21-66	Decal Mower Cutfinger	--	532 17 12-85	Pad Footrest RH STLT
9	532 15 06-17	Decal Fender Husq	--	532 13 83-11	Decal Handle Lft Height Adjust
10	532 14 54-98	Decal Read Owner's Manual Syms.	--	532 18 02-81	Manual Operator's (Euro.)
11	532 15 97-36	Decal Chassis Hot Muffler	--	532 18 02-82	Manual Operator's (Scan.)
12	532 17 05-64	Decal Wheel Steering	Available accessories not included with tractor:		
13	532 15 97-37	Decal Brake/Clutch Symbol LT	--	C42	Grass Catcher
			--	MK420	Mulch Kit w/Blades

WHEELS & TIRES

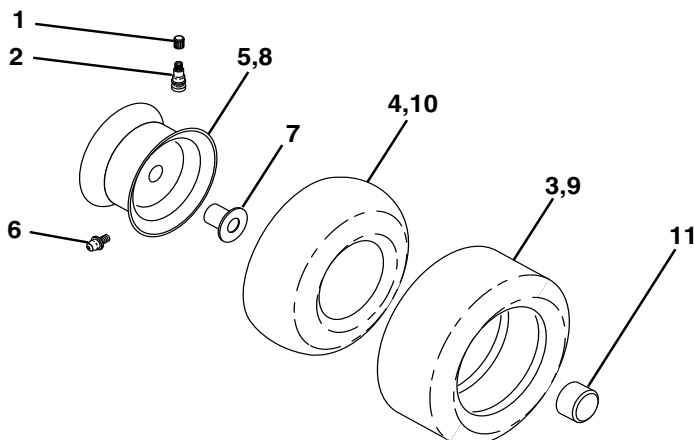

KEY NO.	PART NO.	DESCRIPTION
1	532 05 91-92	Cap Valve Tire
2	532 06 51-39	Stem Valve
3	532 10 62-22	Tire F Ts 15 X 6 0 - 6 Service
4	532 05 99-04	Tube Front (Service Item Only)
5	532 13 83-36	Rim Asm 6" front Silver Service
6	532 12 49-57	Fitting Grease (Front Wheel Only)
7	532 12 49-59	Bearing Flange (Front Wheel Only)
8	532 13 83-37	Rim Asm 8" rear Silver Service
9	532 12 20-82	Tire R Ts 20x10-8 C Service
10	532 12 49-26	Tube Rear (Service Item Only)
11	532 17 50-39	Cap Axle Blk 1 50 X 1 00
--	532 14 43-34	Sealant, Tire (10 oz. Tube)

NOTE: All component dimensions given in U.S. inches
1 inch = 25.4 mm

REPAIR PARTS

TRACTOR - MODEL NO. YTH155 (HEYTH155A), PRODUCT NO. 954 17 00-64
MOWER DECK

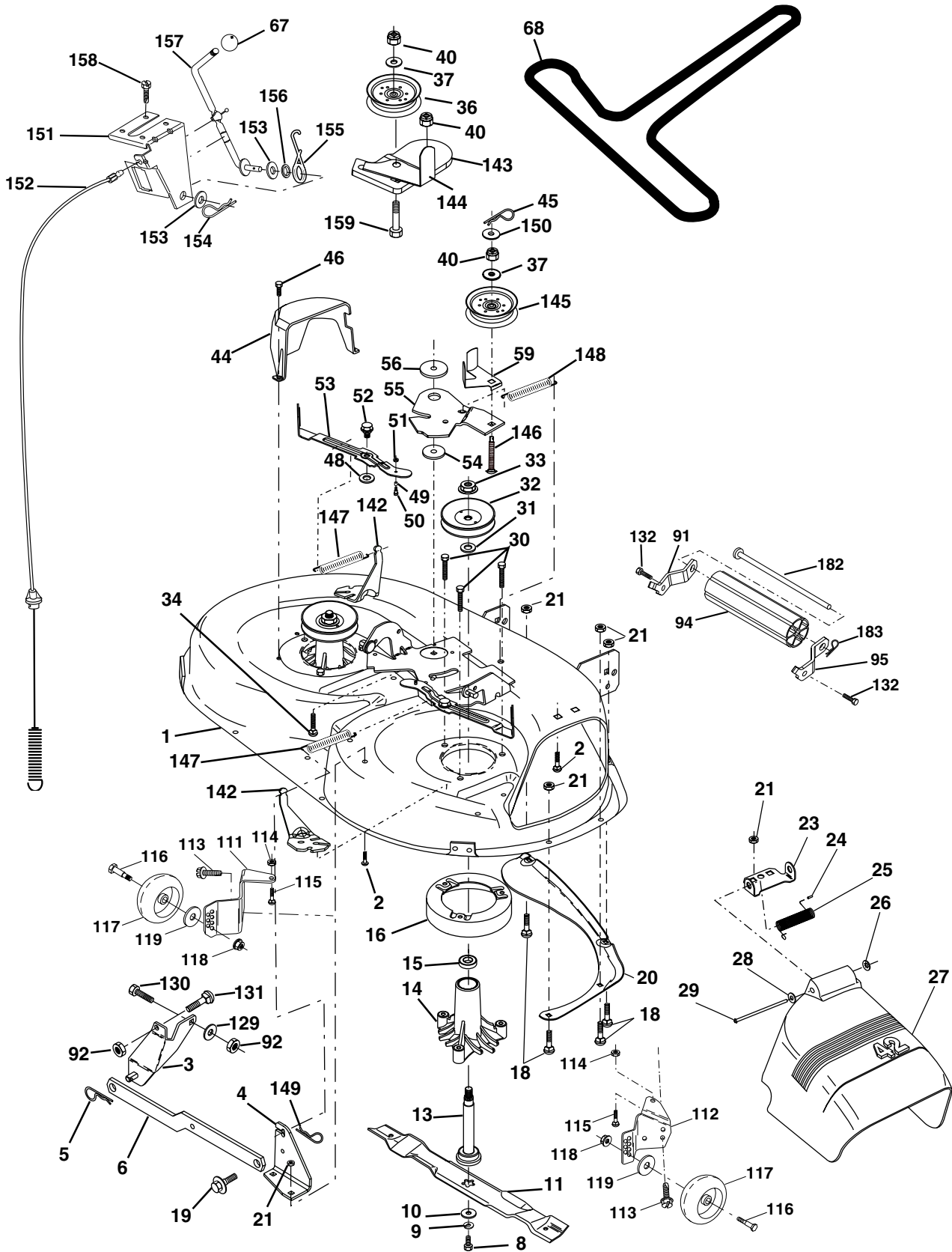

REPAIR PARTS

**TRACTOR - MODEL NO. YTH155 (HEYTH155A), PRODUCT NO. 954 17 00-64
MOWER DECK**

KEY NO.	PART NO.	DESCRIPTION	KEY NO.	PART NO.	DESCRIPTION
1	532 16 58-92	Deck Asm MWR 42"weldment	68	532 18 02-15	V-Belt Mower 42"
2	872 14 05-06	Bolt Rdhd Sqnk 5/16-18unc X3/4	91	532 18 05-32	Bracket Asm Noseroller LH
3	532 13 80-17	Bracket Asm Fr Sway Bar 38/42	92	873 80 06-00	Nut Lock Hex W/Ins 3/8-16 Unc
4	532 16 54-60	Bracket Asm Deck 42"sway Bar	94	532 13 22-64	Roller Nose 38 & 42
5	532 12 46-70	Retainer Spring	95	532 18 05-33	Bracket Asm Noseroller RH
6	532 17 80-24	Bar Sway Deck	111	532 17 92-92	Bracket Wheel Gauge LH 42" Deck
8	532 85 08-57	Bolt 3/8 - 24 X 1.25 Gr 8	112	532 17 92-93	Bracket Gauge Wheel RH 42" Deck
9	810 03 06-00	Washer Lock Hvy 3/8	113	817 06 05-10	Screw 5/16-18
10	532 14 02-96	Washer Hard Blade Mower Vented	114	873 51 05-00	Nut Keps 5/16-18 UNC
11	532 13 84-98	Blade Mower 42"	115	872 11 05-05	Bolt Carriage 5/16-UNC x 5/8
13	532 13 76-45	Shaft Asm W/lower Bearing	116	532 12 48-42	Bolt Shoulder
14	532 12 87-74	Housing Mandrel Vented	117	532 16 57-46	Wheel Gauge
15	532 11 04-85	Bearing Ball Mandrel	118	873 93 06-00	Nut Centerlock 3/8-16 UNC
16	532 17 44-93	Stripper Mower Vented	119	819 12 14-14	Washer 3/8 x 7/8 x 14 Ga.
18	872 14 05-05	Bolt Rdhd Sqnk 5/16-18 X 5/8	129	819 13 13-12	Washer 13/32 x 13/16 x 12 Ga.
19	532 13 28-27	Bolt Shoulder	130	874 78 06-16	Bolt Fin Hex 3/8-16 UNC x 1 Gr. 5
20	532 15 97-70	Baffle Vortex 42	131	872 14 06-08	Bolt Rdhd Sqnk 3/8-16 x 1
21	873 68 05-00	Nut Crownlock 5/16-18 UNC	132	817 06 06-12	Screw 3/8-16 X .75
23	532 17 75-63	Bracket Deflector Mower 42"	142	532 16 58-90	Arm Spring Brake Mower
24	532 10 53-04	Cap Sleeve 80x 112 Blk Mower	143	532 15 71-09	Bracket Arm Idler 42"
25	532 12 37-13	Spring Torsion Deflector 2 52	144	532 15 86-34	Keeper Belt 42" Clutch Idler
26	532 11 04-52	Nut Push Phos & Oil	145	532 16 58-88	Pulley Idler Flat
27	532 17 18-59	Shield Deflector Mower 42" Blk	146	532 17 19-77	Bolt Carriage Idler
28	819 11 10-16	Washer 11/32 X 5/8 X 16 Ga	147	532 17 97-48	Spring Extension
29	532 13 14-91	Rod Hinge 42"6 75 Wlg	148	532 16 90-22	Spring Return Idler
30	532 17 39-84	Screw Thd Rolling Washer Head	149	532 16 98-98	Retainer Spring Yellow
31	532 12 99-63	Washer Spacer Mower Vented	150	819 09 12-16	Washer 9/32 x 3/4 x 16 Ga.
32	532 15 35-35	Pulley Mandrel 42"	151	532 16 96-70	Bracket Clutch Cable
33	532 17 83-42	Nut 9/16 Toplock Flng Oil Dip	152	532 18 15-55	Clutch Cable 42"
34	872 11 06-14	Bolt Rdhd 3/8-16uncx1-3/4 Gr5	153	532 16 96-74	Washer Flat 3/8" Type B
36	532 13 14-94	Pulley Idler Flat 3 060	154	532 16 96-75	Spring Retainer
37	819 13 13-16	Washer 13/32 X 13/16 X 16	155	532 16 96-71	Spring Retention Lvr Cltch Cab
40	873 68 06-00	Nut Crownlock 3/8-16 UNC	156	532 16 96-72	Spacer Clutch Cable
44	532 14 00-88	Guard Mandrel LH Black	157	532 16 96-69	Rod Clutch Cable 3/8"
45	532 12 47-88	Spring Retainer 1" Zinc/cad	158	817 72 04-08	Screw Hex Thd Cut 1/4-20 x 1/2
46	532 13 77-29	Screw Hex Thd Cut 1/4-20x5/8 T	159	872 14 06-14	Bolt Rdhd Sqnk 3/8-16 Unc x 1-3/4
48	532 13 39-44	Washer Hardened Smaller	182	532 17 91-26	Rod Roller Nose Stand.
49	532 17 42-84	Roller Asm Cam Follower	183	532 16 35-52	Retainer Spring Zinc
50	532 13 13-40	Bolt Shldr 10-24 Zinc Gr 5 42"	--	532 13 07-94	Mandrel Asm Service (Includes Housing, Shaft and Shaft Hardware Only-Pulley Not Included)
51	532 06 91-80	Nut Lock #10-24 Unc			
52	532 13 98-88	Bolt Shoulder 5/16-18 Unc Blkz	--	532 18 13-85	Replacement Mower, Complete
53	532 13 18-45	Arm Asm Pad Brake			
54	532 13 39-43	Washer Hardened			
55	532 15 50-46	Arm Idler 42"mower LT/YT			
56	532 16 57-23	Spacer Retainer Mower			
59	532 14 10-43	Guard TUV Idler			
67	532 10 69-32	Knob Rd 3/8-16 Plstc Thds Blk			

NOTE: All component dimensions given in U.S. inches
1 inch = 25.4 mm

REPAIR PARTS

TRACTOR - MODEL NO. YTH155 (HEYTH155A), PRODUCT NO. 954 17 00-64
MOWER LIFT

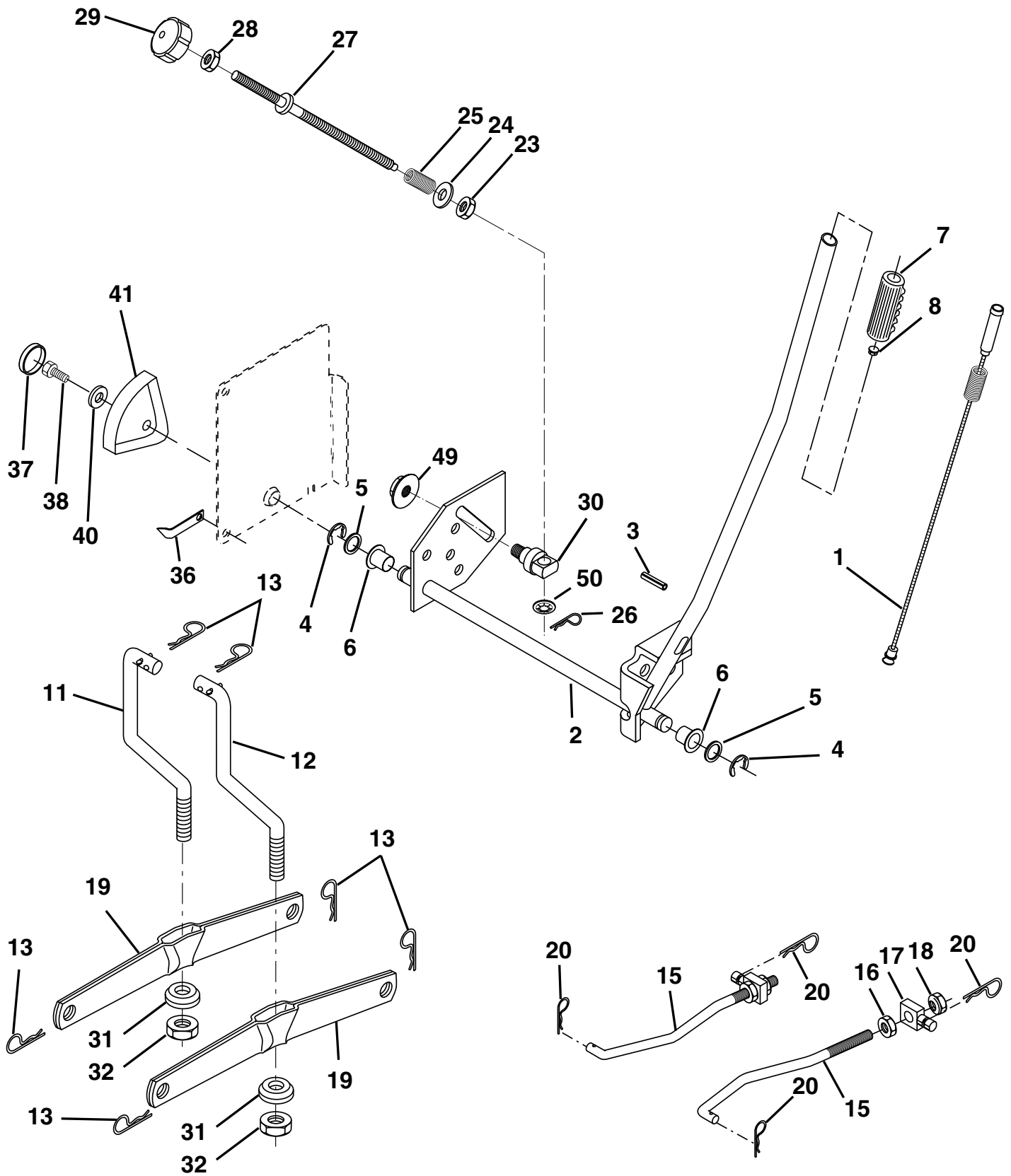

REPAIR PARTS

TRACTOR - MODEL NO. YTH155 (HEYTH155A), PRODUCT NO. 954 17 00-64
MOWER LIFT

KEY NO.	PART NO.	DESCRIPTION
1	532 15 94-60	Wire Asm Inner W/plunger 17 32
2	532 15 94-71	Shaft Asm Lift LH Inf Hgt P/L
3	532 10 57-67	Pin Groove 1 500 Zinc
4	812 00 00-02	E Ring #5133-62
5	819 21 16-21	Washer 21/32 X 1 X 21 Ga
6	532 12 01-83	Bearing Nylon Blk 629 Id
7	532 12 56-31	Grip Handle
8	532 12 45-26	Button Plunger
11	532 13 98-65	Link Lift LH
12	532 13 98-66	Link Lift RH
13	532 12 46-70	Retainer Spring
15	532 17 32-88	Link Front
16	873 35 08-00	Nut Jam Hex 1/2-13 Unc
17	532 17 56-89	Trunnion Blk Zinc
18	873 80 08-00	Nut Lock W/wsh 1/2-13unc
19	532 13 98-68	Arm Suspension Rear
20	532 16 35-52	Retainer Spring
23	532 11 08-07	Nut Special
24	819 13 10-16	Washer 13/32 X 5/8 X 16 Ga
25	532 12 48-74	Spring 2-1/8"
26	532 16 94-84	Retainer Clip
27	532 12 69-71	Rod Adj Lift Zinc 7 49 Wrk Lg
28	873 35 06-00	Nut Hex Jam 3/8-16 Unc
29	532 13 80-57	Knob Inf 3/8-16 Unc Blk W/sym
30	532 15 02-33	Trunnion Inf Height
31	532 16 98-65	Bearing pvt. Lift
32	873 54 06-00	Nut Crownlock 3/8-24
36	532 15 50-97	Pointer pnt Height Ind.
37	532 12 39-35	Plug hole Blk 1.485/1.515 Dia
38	817 06 05-16	Screw 5/16-18 x 1 Smgml Tap/R
40	819 11 24-10	Washer 11/32 x 1-1/2 10 Ga
41	532 15 50-98	Indicator Height
49	532 14 52-12	Nut Hex Flange Lock
50	532 11 04-52	Push Nut

NOTE: All component dimensions given in U.S. inches
1 inch = 25.4 mm

TRACTOR - MODEL NO. YTH155 (HEYTH155A), PRODUCT NO. 954 17 00-64 SCHEMATIC

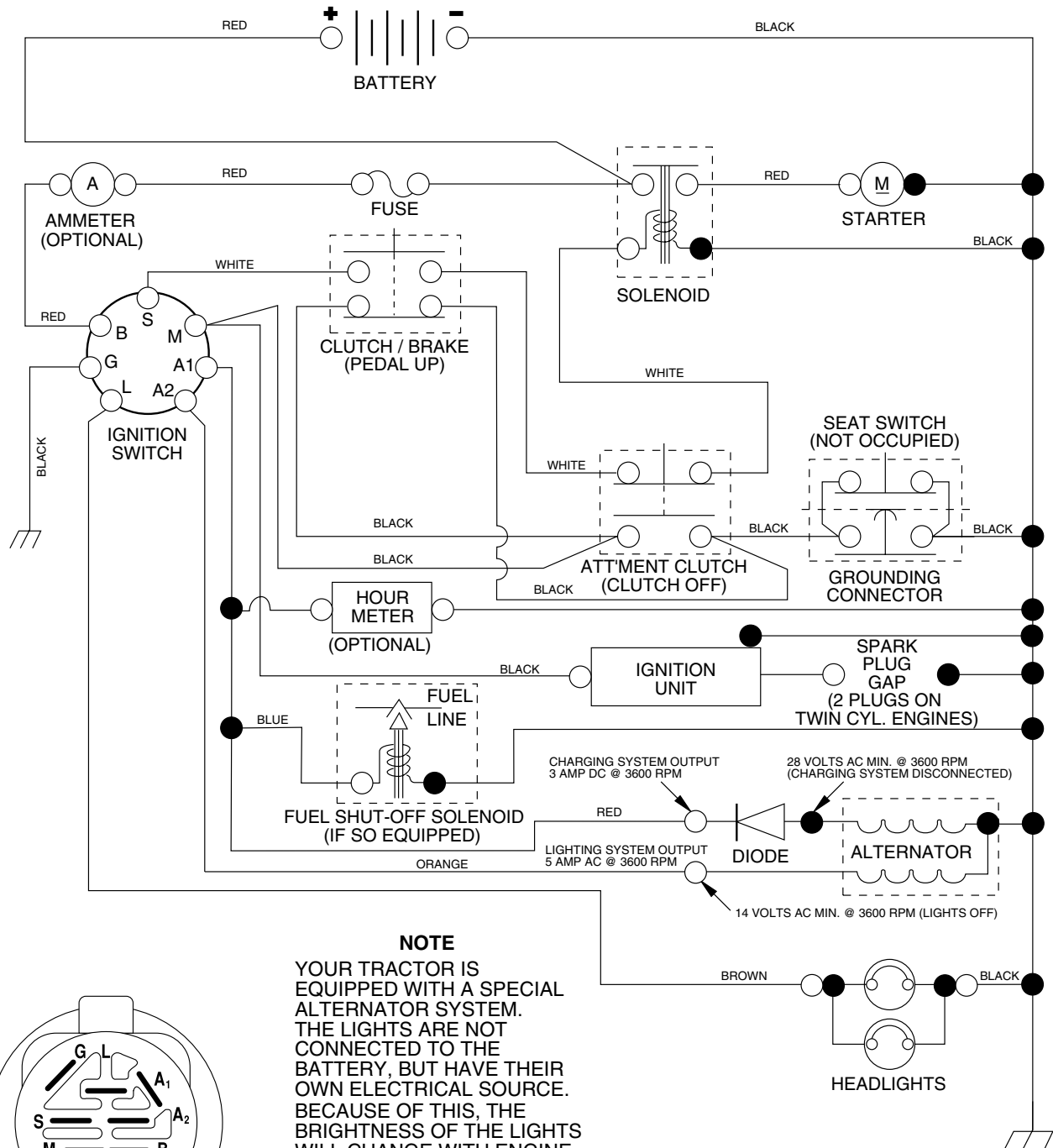

NOTE

YOUR TRACTOR IS EQUIPPED WITH A SPECIAL ALTERNATOR SYSTEM. THE LIGHTS ARE NOT CONNECTED TO THE BATTERY, BUT HAVE THEIR OWN ELECTRICAL SOURCE. BECAUSE OF THIS, THE BRIGHTNESS OF THE LIGHTS WILL CHANGE WITH ENGINE SPEED. AT IDLE THE LIGHTS WILL DIM. AS THE ENGINE IS SPEEDED UP, THE LIGHTS WILL BECOME THEIR BRIGHTEST.

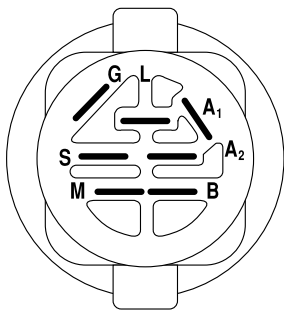

IGNITION SWITCH

POSITION	CIRCUIT	"MAKE"
OFF	M+G+A1	NONE
RUN/LIGHT	B+A1	A2+L
RUN	B+A1	NONE
START	B + S + A1	NONE

WIRING INSULATED CLIPS

NOTE: IF WIRING INSULATED CLIPS WERE REMOVED FOR SERVICING OF UNIT, THEY SHOULD BE REPLACED TO PROPERLY SECURE YOUR WIRING.

NON-REMOVABLE CONNECTIONS

REMOVABLE CONNECTIONS